

## Wirewound Rheostat / Potentiometer



### FEATURES

- 25 W at 25 °C
- CCTU 05-03B (PA1)
- Vitreous - RT style
- Material categorization: for definitions of compliance please see [www.vishay.com/doc?99912](http://www.vishay.com/doc?99912)

**RoHS**  
COMPLIANT

### DIMENSIONS in millimeters

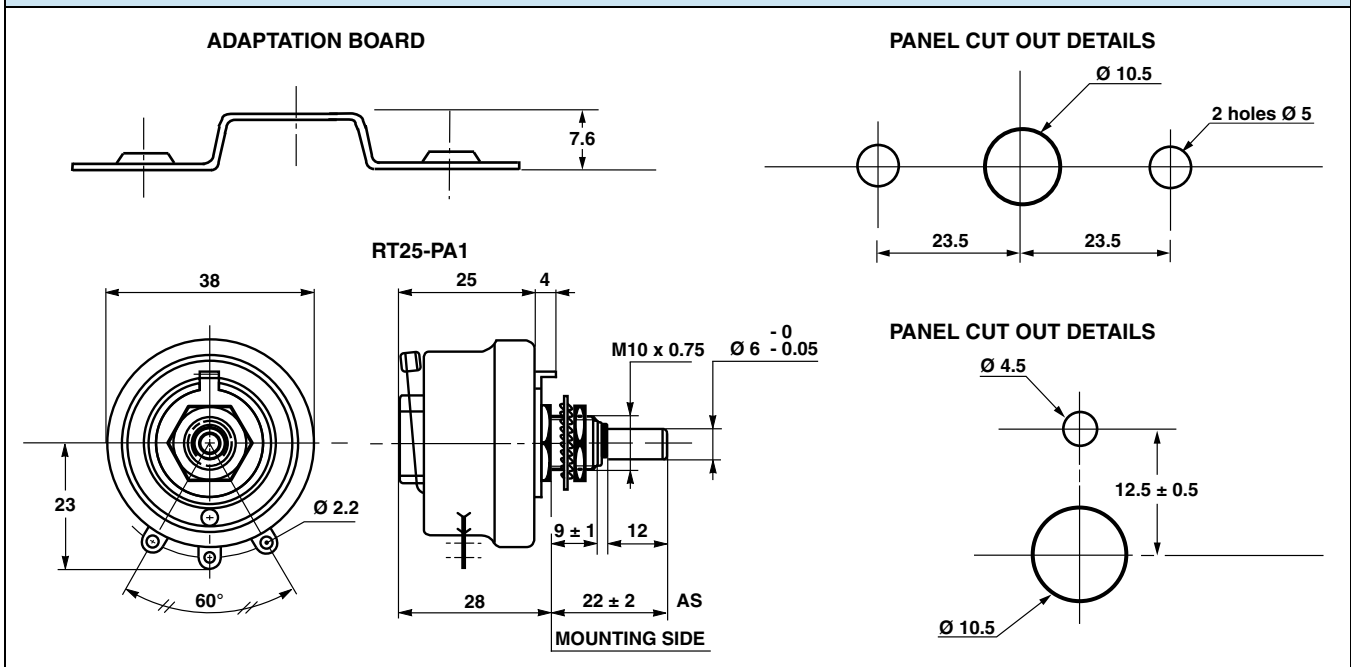

### STANDARD ELECTRICAL SPECIFICATIONS

| MODEL | RESISTANCE RANGE<br>$\Omega$ | TOLERANCE<br>$\pm \%$ | RATED POWER<br>$P_{25\text{ }^\circ\text{C}}$<br>W | VARIATION LAW<br>STANDARD <sup>(1)</sup> | LIMITING<br>ELEMENT VOLTAGE<br>V | DIELECTRIC<br>STRENGTH<br>$V_{\text{RMS}}$ | INSULATION<br>RESISTANCE<br>$\Omega$  |
|-------|------------------------------|-----------------------|--|--|----------------------------------|--|---------------------------------------|
| RT25  | 1 to 4.7K                    | 10                    | 25   | Linear                                   | 300                              | 1000                                       | $10^9\text{M}$ (500 $V_{\text{CC}}$ ) |

**Note**
<sup>(1)</sup> On request: sectorial winding

### CLIMATIC SPECIFICATIONS

|                   |                               |
|-------------------|-------------------------------|
| Temperature range | -55 °C; +320 °C               |
| Climatic category | CCTU 454<br>CEI 55 / 200 / 56 |

### MECHANICAL SPECIFICATIONS

|                       |                         |
|-----------------------|-------------------------|
| Mechanical protection | Vitreous                |
| Mechanical travel     | $300^\circ \pm 5^\circ$ |
| Operating torque      | 1 Ncm to 10 Ncm         |
| End stop torque       | 50 Ncm                  |
| Unit weight           | 80 g                    |

**LOCKING DEVICE**

This is supplied as an option.

The available spindle length is according to the panel thickness.

Order reference: DBA6

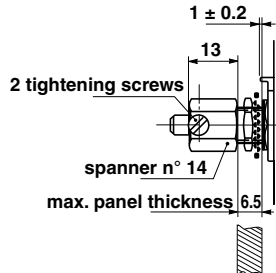
**ADAPTATION BOARD**

This enables 2 point mounting instead of bush mounting. The adaptation board is supplied as an option with 2 mounting screws. Consequently, the available spindle length is reduced by 9.5 mm.

| SPINDLES |                               |                   |      |
|----------|-------------------------------|-------------------|------|
| Ø mm     | DISTANCE TO MOUNTING PLATE mm | SCREW DRIVER SLOT | CODE |
| 6        | 22                            | With              | ASF  |
|          | 25                            | Without           | AM   |
|          |                               | With              | AMF  |
| 6        | 50                            | Without           | AL   |
| 6        | 22                            | Without           | AS   |

**Note**

- For any special requirement on request: spindle flats, etc. Please supply detailed drawing.

**PARTICULAR CHARACTERISTICS**

| NOMINAL RESISTANCE<br>Ω | MAX. SERVICE VOLTAGE<br>V | MAX. CURRENT THROUGH WIPER<br>mA |
|-------------------------|---------------------------|----------------------------------|
| 1                       | 5                         | 5000                             |
| 1.5                     | 6.12                      | 4080                             |
| 2.2                     | 7.42                      | 3370                             |
| 3.3                     | 9.08                      | 2750                             |
| 4.7                     | 10.8                      | 2300                             |
| 6.8                     | 13                        | 1920                             |
| 10                      | 15.8                      | 1580                             |
| 15                      | 19.4                      | 1290                             |
| 22                      | 23.5                      | 1070                             |
| 33                      | 28.7                      | 870                              |
| 47                      | 34.3                      | 730                              |
| 68                      | 41.2                      | 605                              |
| 100                     | 50                        | 500                              |
| 150                     | 61.2                      | 408                              |
| 220                     | 74.2                      | 337                              |
| 330                     | 90.8                      | 275                              |
| 470                     | 108                       | 230                              |
| 680                     | 130                       | 192                              |
| 1K                      | 158                       | 158                              |
| 1.5K                    | 194                       | 129                              |
| 2.2K                    | 235                       | 107                              |
| 3.3K                    | 287                       | 87                               |
| 4.7K                    | 343                       | 73                               |

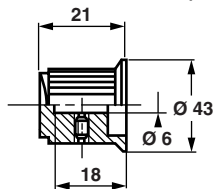
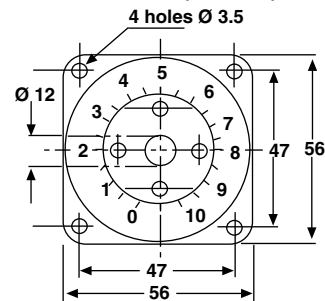
**COMMAND SHAFT 29JF (OPTION)**

**DIAL CG57 (OPTION)**

**MARKING**

Vishay Sfernice trademark, series, style, power rating in watts, ohmic value (in Ω or kΩ), tolerance (in %), maximum current in A, manufacturing date.



| ORDERING INFORMATION |       |         |             |           |           |                |
|----------------------|-------|---------|-------------|-----------|-----------|----------------|
| RT                   | 025   | ASF     | 2201        | K         | B         | XXX            |
| MODEL                | STYLE | SPINDLE | OHMIC VALUE | TOLERANCE | PACKAGING | SPECIAL DESIGN |

| GLOBAL PART NUMBER INFORMATION  |      |                       |   |  |  |                     |   |                            |   |   |   |   |   |   |   |   |   |   |   |   |   |
|---|------|-----------------------|---|--|--|---------------------|---|----------------------------|---|---|---|---|---|---|---|---|---|---|---|---|---|
| <table border="1" style="margin: auto;"> <tr> <td>R</td><td>T</td><td>0</td><td>2</td><td>5</td><td>A</td><td>S</td><td>1</td><td>0</td><td>R</td><td>0</td><td>K</td><td>B</td> </tr> </table> |      |                       |   |  |  |                     |   |                            | R | T | 0 | 2 | 5 | A | S | 1 | 0 | R | 0 | K | B |
| R   | T    | 0                     | 2   | 5  | A  | S                   | 1   | 0                          | R | 0 | K | B |   |   |   |   |   |   |   |   |   |
| GLOBAL MODEL  | SIZE | LOCKING DEVICE (OPT.) | WINDING (OPT.)  | COMMAND SHAFT  | OHMIC VALUE  | TOLERANCE           | PACKAGING   | SPECIAL                    |   |   |   |   |   |   |   |   |   |   |   |   |   |
| RT  | 025  | D                     | BXXX or BXXXX<br>As applicable xxx(x) = internal number | AS = standard (Diam: 6 mm)<br>AM<br>AMF<br>AL<br>ASF | The three first digits are significant figures and the last digit specifies the number of zeros to follow. R designates decimal point.<br><br>2002 = 20 kΩ<br>4700 = 470 Ω<br>10R0 = 10 Ω<br>0R01 = 0.01 Ω | J = 5 %<br>K = 10 % | B = bulk<br>BO10<br><br>No standard packaging:<br>N = bulk, qty. open | As applicable<br>Ex = DXxx |   |   |   |   |   |   |   |   |   |   |   |   |   |

| RELATED DOCUMENTS   |  |
|---|--|
| APPLICATION NOTES   |  |
| Potentiometers and Trimmers                                       | <a href="http://www.vishay.com/doc?51001">www.vishay.com/doc?51001</a> |
| Guidelines for Vishay Sfernice Resistive and Inductive Components | <a href="http://www.vishay.com/doc?52029">www.vishay.com/doc?52029</a> |



## Disclaimer

ALL PRODUCT, PRODUCT SPECIFICATIONS AND DATA ARE SUBJECT TO CHANGE WITHOUT NOTICE TO IMPROVE RELIABILITY, FUNCTION OR DESIGN OR OTHERWISE.

Vishay Intertechnology, Inc., its affiliates, agents, and employees, and all persons acting on its or their behalf (collectively, "Vishay"), disclaim any and all liability for any errors, inaccuracies or incompleteness contained in any datasheet or in any other disclosure relating to any product.

Vishay makes no warranty, representation or guarantee regarding the suitability of the products for any particular purpose or the continuing production of any product. To the maximum extent permitted by applicable law, Vishay disclaims (i) any and all liability arising out of the application or use of any product, (ii) any and all liability, including without limitation special, consequential or incidental damages, and (iii) any and all implied warranties, including warranties of fitness for particular purpose, non-infringement and merchantability.

Statements regarding the suitability of products for certain types of applications are based on Vishay's knowledge of typical requirements that are often placed on Vishay products in generic applications. Such statements are not binding statements about the suitability of products for a particular application. It is the customer's responsibility to validate that a particular product with the properties described in the product specification is suitable for use in a particular application. Parameters provided in datasheets and / or specifications may vary in different applications and performance may vary over time. All operating parameters, including typical parameters, must be validated for each customer application by the customer's technical experts. Product specifications do not expand or otherwise modify Vishay's terms and conditions of purchase, including but not limited to the warranty expressed therein.

Hyperlinks included in this datasheet may direct users to third-party websites. These links are provided as a convenience and for informational purposes only. Inclusion of these hyperlinks does not constitute an endorsement or an approval by Vishay of any of the products, services or opinions of the corporation, organization or individual associated with the third-party website. Vishay disclaims any and all liability and bears no responsibility for the accuracy, legality or content of the third-party website or for that of subsequent links.

Vishay products are not designed for use in life-saving or life-sustaining applications or any application in which the failure of the Vishay product could result in personal injury or death unless specifically qualified in writing by Vishay. Customers using or selling Vishay products not expressly indicated for use in such applications do so at their own risk. Please contact authorized Vishay personnel to obtain written terms and conditions regarding products designed for such applications.

No license, express or implied, by estoppel or otherwise, to any intellectual property rights is granted by this document or by any conduct of Vishay. Product names and markings noted herein may be trademarks of their respective owners.