



Design Considerations for Surface-Mount Devices

By Vishay Barry

In many applications, surface-mount technology (SMT) has replaced traditional PCB construction, where elements of the components are mounted in openings through the board. In IPC-7351, SMT is defined as:

“The electrical connection of components to the surface of a conductive pattern that does not utilize component holes.”

In addition, for the purposes of this discussion, a surface-mount device (SMD) will have all of its interconnecting terminals, including ground(s), on the same plane. An example of a surface-mount attenuator mounted to a PCB is shown in Fig. 1.

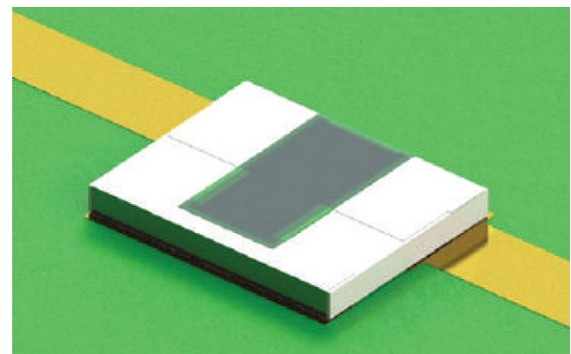

Fig. 1 - SMD Attenuator on Board

The use of SMT assembly offers a number of advantages, including reduced component size and the ability to mount components in almost any location on both sides of the board. This leads directly to significant decreases in the size and weight of the resulting assembly. With these advantages, however, come additional complexities in the design. The main areas of concern are thermal dissipation and high frequency electrical performance. In addition, soldering requires careful consideration, as interconnect density is typically greatly increased.

SMT assembly is usually accomplished using tin-bearing solders. Proper soldering technique is paramount to reliability. Vishay Barry has designed its devices to be soldered in accordance with the IPC-A-610 industry standard. This standard is quite extensive and is available for purchase at www.ipc.org. For the purposes of this discussion, a few of the standard’s key elements will be highlighted.

IPC-A-610 defines an acceptable solder joint to have the following characteristics:

- A solder fillet will appear generally smooth and exhibits good wetting of the solder to the parts being joined
- The outline of the parts being soldered is easily determined
- Solder at the joint creates a feathered or blended edge
- The fillet is either concave in shape or has a wetting angle not exceeding 90°

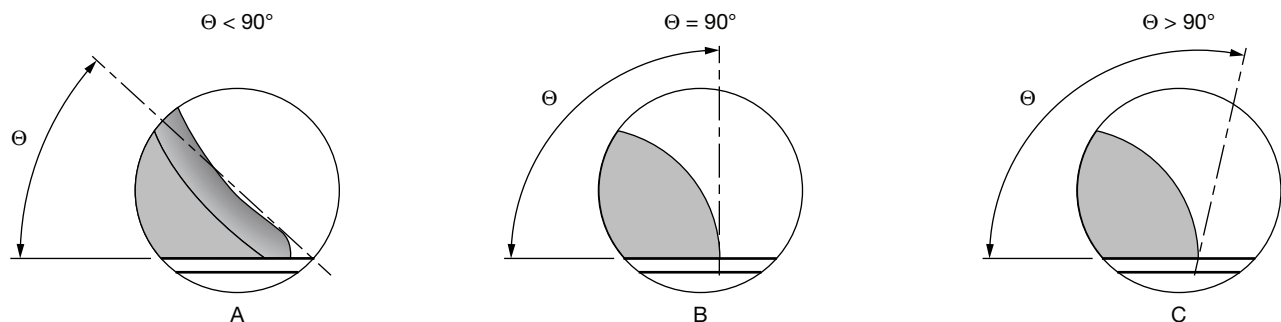

Fig. 2 - IPC-A-610 Solder Wetting Angles

The DNA of tech.®

Design Considerations for Surface-Mount Devices

Fig. 2 illustrates the definition of the wetting angle as specified in IPC-A-610.

In addition, the land pattern design must take into account both the requirements for forming a reliable solder joint and the performance concerns discussed later.

To achieve optimum solder joint characteristics, the guidance of IPC-7351, Generic Requirements for Surface-Mount Design and Land Pattern Standard, should be followed.

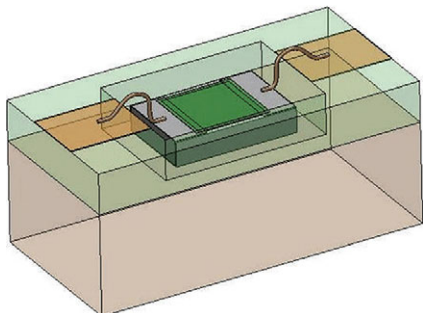

Fig. 3 - Resistor Mounted on Ground Plane Through PCB

Thermal energy in an SMD must be carried away from the component at a rate sufficient to limit the temperature rise to a level that does not cause damage. Because the thermal resistance of a typical PCB is much higher than a heatsink, it is often a challenge to design a PCB capable of dissipating the full rated power of the component. Careful analysis and in-application testing are recommended to ensure that the device is operating within the specified limits. Greater detail is available in Vishay Barry's application note "SMD Resistor Thermal Analysis".

When a component is mounted in such a way that its ground plane is in contact with the ground plane of the interconnecting circuitry, as shown in Fig. 3, the majority of the electromagnetic fields are contained within the device.

In this case, the effects of the PCB on the electromagnetic characteristics of the device are relatively minor and related to the parasitic reactance of the interconnects.

When a component is mounted on the surface of the PCB, as shown in Fig. 4, however, the electromagnetic fields are present in both the component and the PCB. The characteristics of the PCB, including the relative permittivity and distance to ground surfaces, become primary factors in the overall performance of the component. The design of the PCB - including the interconnecting transmission lines, component land pattern, relative permittivity of the PCB, distance to ground surfaces, and interconnecting vias - must be taken into account in modeling the component's performance.

Vishay Barry offers attenuator, resistor, and termination chip devices in a wide array of package styles. Some of these package styles are designed for SMT assembly, while others require mounting through a PCB to operate as specified. The following table lists the available terminal configurations and the intended board configuration.

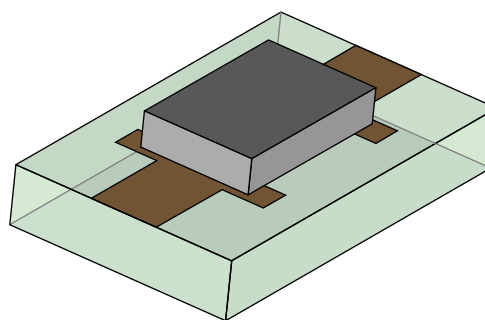
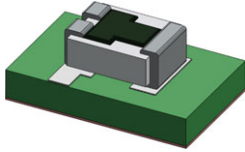
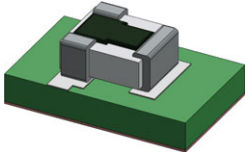
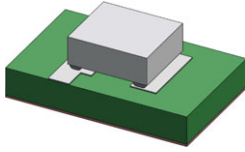
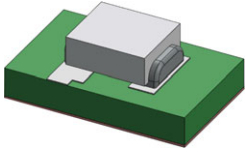
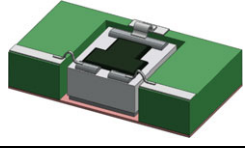
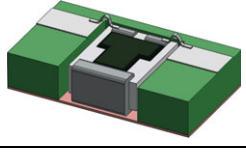
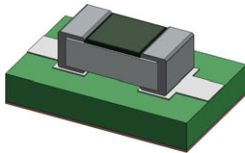
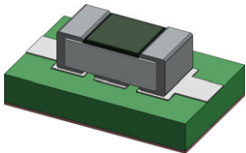
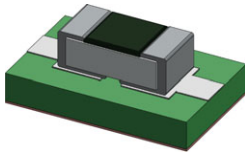
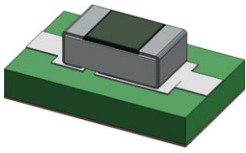
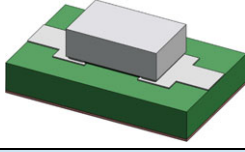
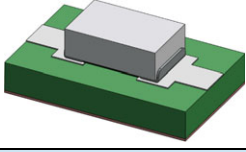
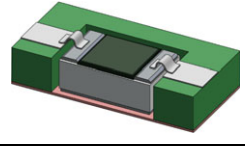
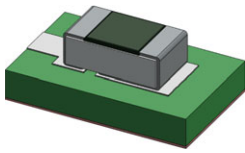

Fig. 4 - SMT Resistor on PCB Surface

The DNA of tech.®

Design Considerations for Surface-Mount Devices

SMD ATTENUATORS			
<p>AP Type full wraparound</p> 	<p>AT Type 3-sided wraparound</p> 		
FLIP-CHIP SMD ATTENUATORS			
<p>AS Type single-sided</p> 	<p>AK Type 1/4 wraparound</p> 		
PCB CAVITY ATTENUATORS			
<p>AM Type single-sided with backplane</p> 	<p>AV Type 1/2 wraparound to ground</p> 		
SMD RESISTORS			
<p>RP Type full wraparound</p> 	<p>RY Type wraparound with isolated center pad</p> 		
<p>RE Type wraparound with both mounting pads extended</p> 	<p>RZ Type wraparound with one extended mounting pad</p> 		
FLIP-CHIP SMD RESISTORS			
<p>RS Type single-sided</p> 	<p>RK Type 1/4 wraparound</p> 		
PCB CAVITY RESISTORS			
<p>RM Type single-sided with backplane</p> 			
SMD TERMINATION			
<p>TZ Type wraparound with extended mounting pad connected to ground</p> 	<p>TV Type 1/2 wraparound to ground</p> 