

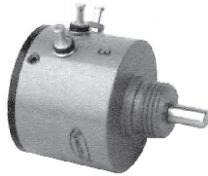

7/8" (22.2 mm) Single Turn Wirewound (Precision Potentiometer)



FEATURES

- Large range of ohmic values: From 5 Ω up to 100 kΩ
- Bushing mount or servo mount types are available
- Extra taps upon request
- Gangable up to 6 sections
- Material categorization: for definitions of compliance please see www.vishay.com/doc?99912



RoHS
COMPLIANT

QUICK REFERENCE DATA	
Sensor type	ROTATIONAL, single turn wirewound
Output type	Output by turrets
Market appliance	Professional
Dimensions	7/8" (22.2 mm)

ELECTRICAL SPECIFICATIONS		
PARAMETER	STANDARD	SPECIAL
Total resistance: (bushing 91 kΩ max.) Tolerance: 20 Ω and above Below 20 Ω	5 Ω to 20 kΩ ± 3 % ± 5 %	to 30 kΩ ± 1 % ± 3 %
Absolute minimum resistance	Linearity x total resistance or 0.5 Ω whichever is greater	
End voltage	Linearity x total applied voltage for total resistance above 20 Ω, 2.0 % of total applied voltage for 20 Ω and below	
Linearity (independent) 5 Ω to 100 Ω 100 Ω to 500 Ω 500 Ω to 5 kΩ 5 kΩ and above	STANDARD ± 1.0 % ± 1.0 % ± 0.5 % ± 0.5 %	BEST PRACTICAL ± 0.75 % ± 0.50 % ± 0.35 % ± 0.25 %
Noise	100 Ω ENR	
Electrical angle	350° ± 2°	
Power rating Section 1 Additional sections	1.25 W at 70 °C ambient derated to zero at 125 °C 75 % of the rating of section 1 (0.94 W at 70 °C)	
Insulation resistance	1000 MΩ minimum, 500 V _{DC}	
Dielectric strength	1000 V _{RMS} , 60 Hz	
Taps (extra)	9 available as special, standard tolerance ± 2°	
Phasing (CCW end points)	Additional sections phased to section 1 within ± 1°	

ORDERING INFORMATION														
7	0	2	S	1	2	0	3	2	0	3	X	X	X	X
MODEL	STYLE	GANGS	OHMIC VALUE GANGS Nº 1				OHMIC VALUE GANGS Nº 2				SPECIAL REQUEST			
702	B: bushing S: servo	1 2 3 4 5 6	470 = 47 Ω 222 = 2.200 Ω 103 = 10 kΩ For ohmic value range see electrical specification				470 = 47 Ω 222 = 2.200 Ω 103 = 10 kΩ For ohmic value range see electrical specification				Custom reference			

PART NUMBER DESCRIPTION (for information only)					
702-	2	1	203	203	XXXX
MODEL	STYLE	GANGS	OHMIC VALUE GANGS Nº 1	OHMIC VALUE GANGS Nº 2	SPECIAL
	B = 1 S = 2				

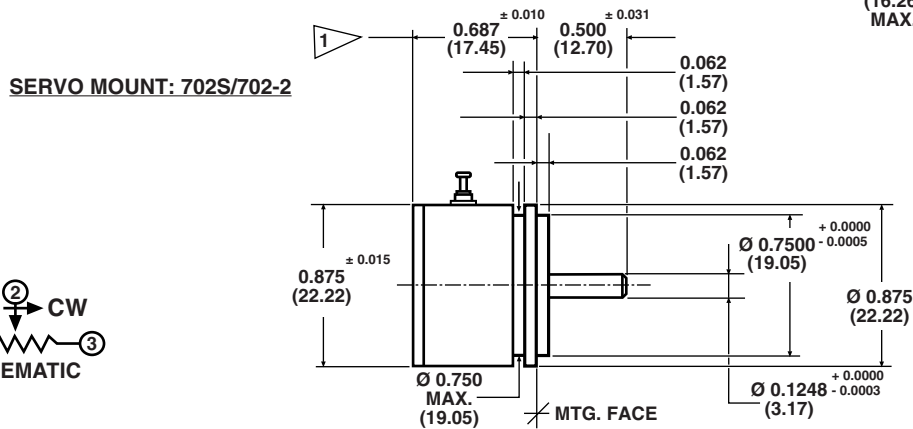
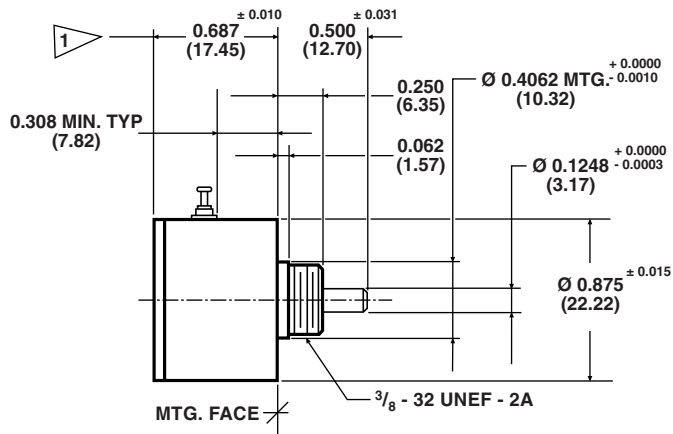
DIMENSIONS in inches (millimeters)

① ADD 0.500 (12.70) ± 0.002 FOR EACH ADDITIONAL SECTION

TOLERANCES: UNLESS OTHERWISE NOTED. DECIMALS ± 0.005 ANGLES ± 2°

MECHANICAL SPECIFICATIONS

PARAMETER		
Rotation	360° continuous	
Bearing type	SERVO Ball bearing	BUSHING Sleeve bearing
Ganging	6 sections maximum Terminal alignment, added sections within ± 10° of section 1 terminals	
Torque (maximum)	STARTING	RUNNING
Servo section 1	0.10 oz. - in (7.20 g - cm)	0.085 oz. - in (6.12 g - cm)
Bushing section 1	0.25 oz. - in (18.00 g - cm)	0.20 oz. - in (14.40 g - cm)
Each additional section	0.10 oz. - in (7.20 g - cm)	0.075 oz. - in (5.40 g - cm)
Mechanical runouts (maximums):	SERVO	BUSHING
Shaft runout (TIR/in)	0.002" (0.05 cm)	0.002" (0.05 cm)
Pilot dia. runout (TIR)	0.002" (0.05 cm)	0.002" (0.05 cm)
Lateral runout (TIR)	0.002" (0.05 cm)	0.005" (0.13 cm)
Shaft end play	0.005" (0.13 cm)	0.005" (0.13 cm)
Shaft radial play	0.002" (0.05 cm)	0.004" (0.10 cm)
Moment of inertia	0.12 g - cm ² per section maximum	
Weight:		
Single section	0.6 oz. (17.01 g)	
Each additional section	0.2 oz. (5.67 g)	



MATERIAL SPECIFICATIONS	
Housing and lids	Aluminum, anodized
Shaft	Stainless steel, non-magnetic non-passivated
Terminals	Brass, plated for solderability
Bushing mount hardware Lockwasher internal tooth: Panel nut:	Steel, nickel plated Brass, nickel plated

MARKING	
Unit identification	Units shall be marked with Vishay Spectrol name, model no and date code, and on each section: resistance, resistance tolerance, linearity and terminal identification. Example of a marking for a standard part: 702-11502

ENVIRONMENTAL SPECIFICATIONS	
Vibration	15 g thru 2000 CPS
Shock	50 g
Salt spray	96 h
Rotational life	1 million shaft revolutions
Load life	900 h
Operating temperature range:	-55 °C +125 °C

Note

- Nothing stated herein shall be construed as a guarantee of quality or durability

POWER RATING CHART

(Ratings for cup N°. 1. Additional cups 75 % of values shown)

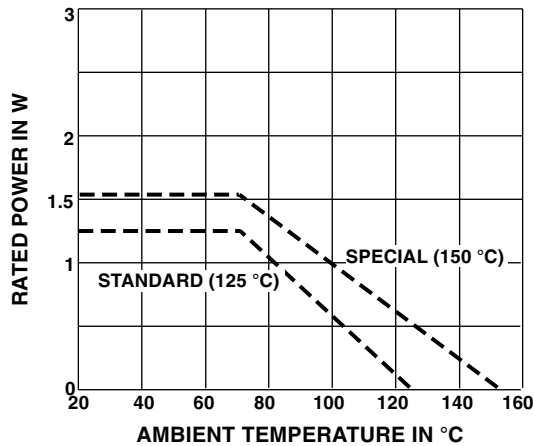

RESISTANCE ELEMENT DATA					
STANDARD RESISTANCE VALUES (Ω)	RESOLUTION (%)	OHMS PER TURN	MAXIMUM CURRENT AT 70 °C AMBIENT (mA)	MAXIMUM VOLTAGE ACROSS COIL (V)	WIRE TEMP. COEF. (ppm/°C)
5	0.460	0.023	500	2.50	800
10	0.378	0.038	354	3.54	800
20	0.374	0.075	250	5.00	180
50	0.300	0.150	158	7.90	180
100	0.271	0.271	112	11.2	20
200	0.235	0.478	79.1	15.8	20
500	0.206	1.03	50.0	25.0	20
1K	0.156	1.56	35.4	35.4	20
2K	0.127	2.55	25.0	50.0	20
5K	0.101	5.07	15.8	79.0	20
10K	0.095	8.50	11.2	112.0	20
20K	0.090	17.9	7.90	158.0	20
50K	0.075	37.9	5.00	250.0	20
100K	0.065	64.5	3.54	354.0	20



Disclaimer

ALL PRODUCT, PRODUCT SPECIFICATIONS AND DATA ARE SUBJECT TO CHANGE WITHOUT NOTICE TO IMPROVE RELIABILITY, FUNCTION OR DESIGN OR OTHERWISE.

Vishay Intertechnology, Inc., its affiliates, agents, and employees, and all persons acting on its or their behalf (collectively, "Vishay"), disclaim any and all liability for any errors, inaccuracies or incompleteness contained in any datasheet or in any other disclosure relating to any product.

Vishay makes no warranty, representation or guarantee regarding the suitability of the products for any particular purpose or the continuing production of any product. To the maximum extent permitted by applicable law, Vishay disclaims (i) any and all liability arising out of the application or use of any product, (ii) any and all liability, including without limitation special, consequential or incidental damages, and (iii) any and all implied warranties, including warranties of fitness for particular purpose, non-infringement and merchantability.

Statements regarding the suitability of products for certain types of applications are based on Vishay's knowledge of typical requirements that are often placed on Vishay products in generic applications. Such statements are not binding statements about the suitability of products for a particular application. It is the customer's responsibility to validate that a particular product with the properties described in the product specification is suitable for use in a particular application. Parameters provided in datasheets and / or specifications may vary in different applications and performance may vary over time. All operating parameters, including typical parameters, must be validated for each customer application by the customer's technical experts. Product specifications do not expand or otherwise modify Vishay's terms and conditions of purchase, including but not limited to the warranty expressed therein.

Hyperlinks included in this datasheet may direct users to third-party websites. These links are provided as a convenience and for informational purposes only. Inclusion of these hyperlinks does not constitute an endorsement or an approval by Vishay of any of the products, services or opinions of the corporation, organization or individual associated with the third-party website. Vishay disclaims any and all liability and bears no responsibility for the accuracy, legality or content of the third-party website or for that of subsequent links.

Except as expressly indicated in writing, Vishay products are not designed for use in medical, life-saving, or life-sustaining applications or for any other application in which the failure of the Vishay product could result in personal injury or death. Customers using or selling Vishay products not expressly indicated for use in such applications do so at their own risk. Please contact authorized Vishay personnel to obtain written terms and conditions regarding products designed for such applications.

No license, express or implied, by estoppel or otherwise, to any intellectual property rights is granted by this document or by any conduct of Vishay. Product names and markings noted herein may be trademarks of their respective owners.