

## Single Turn Bushing Mount Hall Effect Sensor in Size 09 (22.2 mm)



### FEATURES

- Accurate linearity down to:  $\pm 0.5\%$
- All electrical angles available up to:  $360^\circ$  (no dead band)
- Long life: greater than 10M cycles
- Non contacting technology: hall effect
- Model dedicated to all applications in harsh environments
- Material categorization: for definitions of compliance please see [www.vishay.com/doc?99912](http://www.vishay.com/doc?99912)

**RoHS**  
COMPLIANT

### QUICK REFERENCE DATA

Sensor type	ROTATIONAL, single turn hall effect
Output type	Wires
Market appliance	Industrial
Dimensions	7/8" (22.2 mm)

### ELECTRICAL SPECIFICATIONS

PARAMETER	STANDARD	SPECIAL
Electrical angle	$90^\circ, 180^\circ, 270^\circ, 360^\circ$	Any other angle upon request
Linearity	$\pm 1\%$	$\pm 0.5\%$
Supply voltage	$5 V_{DC} \pm 10\%$	Other upon request
Supply current	10 mA typical	16 mA for PWM output
Output signal	Analog ratiometric 10 % to 90 % of $V_{supply}$ or PWM 10 % to 90 % duty cycle	Other upon request
Over voltage protection (input)	$+28 V_{DC}$	
Reverse voltage protection (input)	$-14 V_{DC}$	
Over voltage protection (output)	$+28 V_{DC}$ ( $+38 V_{DC}$ peak - 1 h at $+25^\circ C$ )	
Recommended load resistance	Min. 1 k $\Omega$ for analog output and PWM output	
Hysteresis	$< 0.35^\circ$	

### MECHANICAL SPECIFICATIONS

PARAMETER	
Mechanical travel	$360^\circ$ continuous, stops upon request: $340^\circ \pm 3^\circ$
Bearing type	Sleeve bearing
Standard	IP 50; other on request
Weight	20 g $\pm$ 2 g

### ORDERING INFORMATION / DESCRIPTION

351HE	0	A	1	W	A	1S22	XXXX	BO 10	e1
MODEL	FEATURES	LINEARITY	ELECTRICAL ANGLE	OUTPUT TYPE	OUTPUT SIGNAL	SHAFT TYPE	SPECIAL REQUEST	PACKAGING	LEAD FINISH
<b>0:</b> continuous rotation and antirotation pin	<b>A:</b> $\pm 1\%$ <b>B:</b> $\pm 0.5\%$	<b>1:</b> $90^\circ$ <b>2:</b> $180^\circ$ <b>3:</b> $270^\circ$ <b>4:</b> $360^\circ$ <b>9:</b> other angles	<b>W:</b> wires <b>Z:</b> custom	<b>A:</b> analog CW <b>B:</b> analog CCW <b>C:</b> PWM CW <b>D:</b> PWM CCW <b>Z:</b> other output	<b>0:</b> 6 mm <b>1:</b> 6.35 mm <b>2:</b> 3.175 mm <b>9:</b> special <b>P:</b> plain <b>S:</b> slotted <b>Z:</b> other type			Box of 10 pieces	
<b>1:</b> continuous rotation and no antirotation pin									
<b>2:</b> stops at $330^\circ$ and antirotation pin									
<b>3:</b> stops at $330^\circ$ and no antirotation pin									
Shaft length from mounting face 22 mm to 72 mm max. per step of 5 mm									

### SAP PART NUMBERING GUIDELINES

351HE	1	B	9	Z	C	0P27	XXXX
MODEL	MECHANICAL FEATURES	LINEARITY	ELECTRICAL TYPE	OUTPUT ANGLE	OUTPUT SIGNAL	SHAFT TYPE	SPECIAL REQUEST



**V<sub>OUT</sub> ANALOG**

Operating temperature	85 °C	125 °C
Diagnostic high level	96 % min.	96 % min.
Diagnostic low level	2 % max.	4 % max.

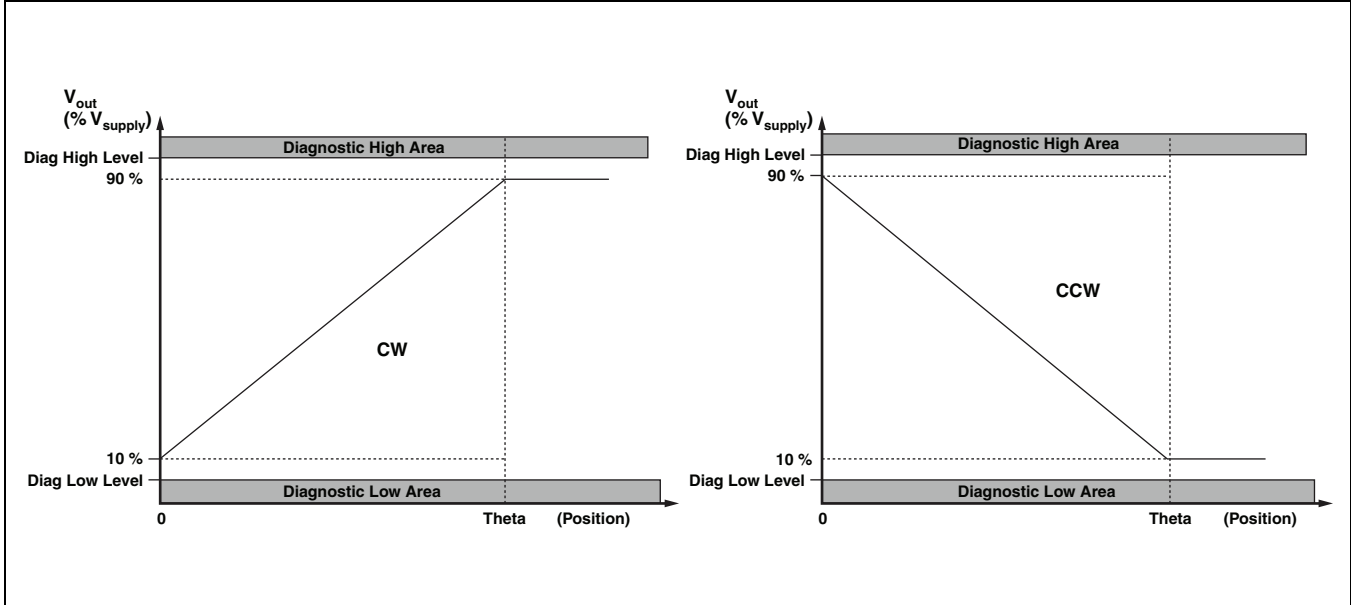

**V<sub>OUT</sub> PWM**

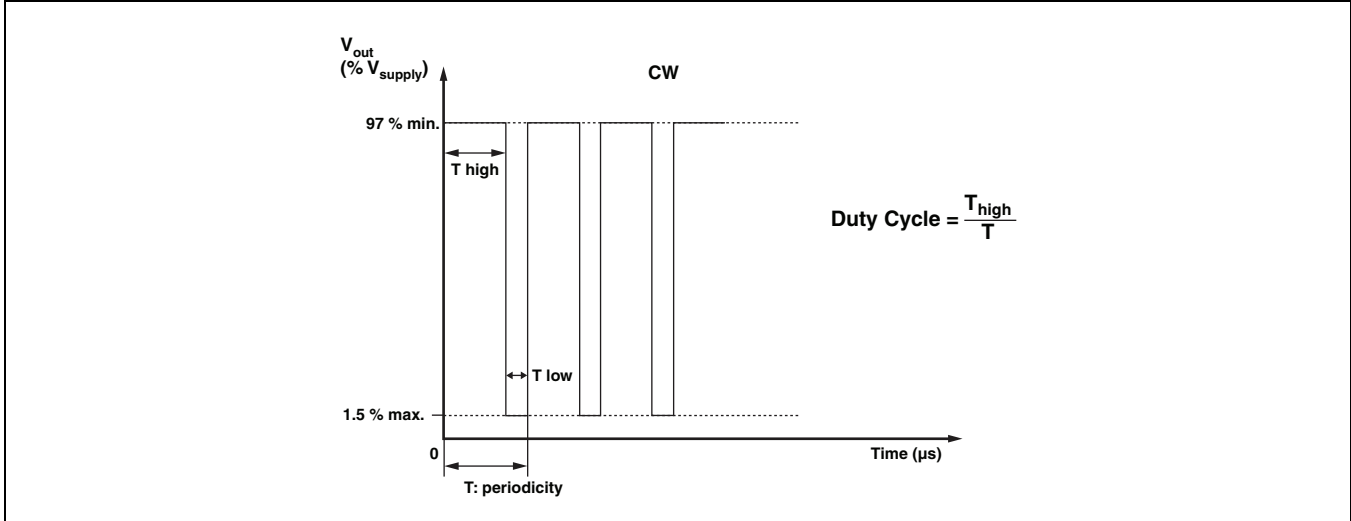

<b>DIAGNOSTIC MODES</b>			
<b>FAILURE</b>	<b><math>V_{out}</math> ANALOG <math>R_{pull-up}</math></b>	<b><math>V_{out}</math> ANALOG <math>R_{pull-down}</math></b>	<b><math>V_{out}</math> PWM <math>R_{pull-up} = 1\text{ k}\Omega</math> <math>V_{pull-up} = V_{supply} = 5\text{ V}</math></b>
1: Broken GND	Diagnostic high area	Diagnostic low area	> 97 % $V_{supply}$ without modulation
2: Broken $V_{out}$	Diagnostic high area	Diagnostic low area	> 97 % $V_{supply}$ without modulation
3: Broken $V_{supply}$	Diagnostic high area	Diagnostic low area	> 97 % $V_{supply}$ without modulation
Over voltage $V_{supply} > 7\text{ V}$	Diagnostic high area	Diagnostic low area	> 97 % $V_{supply}$ without modulation
Under voltage $V_{supply} < 2.7\text{ V}$	Diagnostic high area	Diagnostic low area	> 97 % $V_{supply}$ without modulation

$V_{pull-up}$  can be independent to  $V_{supply}$

<b>ENVIRONMENTAL SPECIFICATIONS</b>	
Vibrations	20 g from 10 Hz to 2000 Hz
Shocks	3 shocks/axis; 50 g half a sine 11 ms
Operating temperature range	-45 °C; +125 °C
Life	> 10M of cycles
Rotational speed (max.)	120 rpm
Immunity to radiated electromagnetic disturbances	200 V/m 150 kHz/1 GHz
Immunity to power frequency magnetic field	200 A/m 50 Hz/60 Hz
Radiated electromagnetic emissions	30 MHz/1 GHz < 30 dBμV/m
Electrostatic discharges	Contact discharges: ± 4 kV Air discharges: ± 8 kV
<b>MATERIALS</b>	
Housing	Thermoplastic housing
Bushing	Brass nickel plated
Shaft	Stainless steel
Output	3 lead wires
<b>BUSHING MOUNT HARDWARE</b>	
Lockwasher internal tooth	Steel nickel plated
Panel nut	Brass nickel plated

**Note**

- Nothing stated herein shall be construed as a guarantee of quality or durability



### DIMENSIONS in millimeters

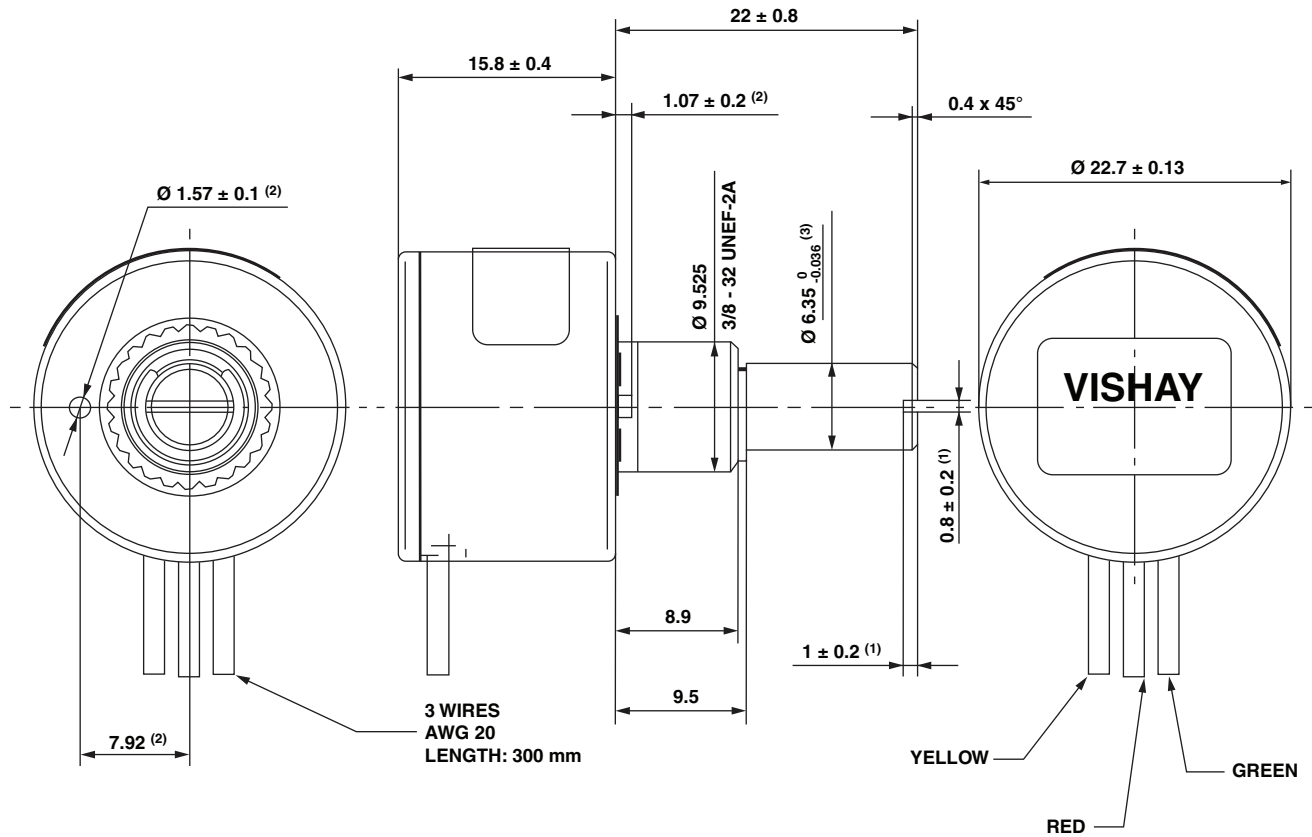

GENERAL TOLERANCE:  $\pm 0.5 \text{ mm}$

CW OR CCW ACCORDING  
OUTPUT MODE CHOICE

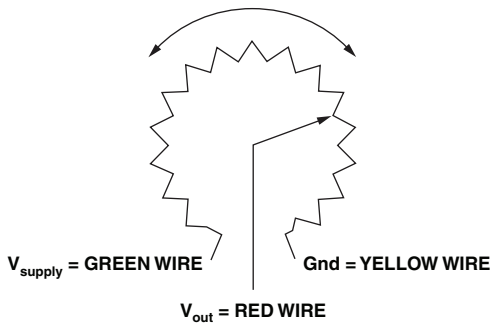

VIEWED FROM SHAFT

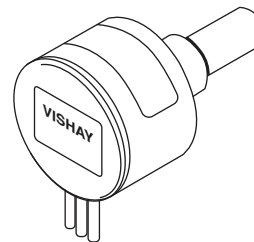

### Notes

- (1) For version slotted shaft
- (2) For version non turn pin
- (3) For shaft type "1"

### MARKING

<b>Unit Identification</b>	Manufacturer's name and complete sap part reference, date code, and wiring correspondence: colors versus connections.
----------------------------	---



## **Disclaimer**

ALL PRODUCT, PRODUCT SPECIFICATIONS AND DATA ARE SUBJECT TO CHANGE WITHOUT NOTICE TO IMPROVE RELIABILITY, FUNCTION OR DESIGN OR OTHERWISE.

Vishay Intertechnology, Inc., its affiliates, agents, and employees, and all persons acting on its or their behalf (collectively, "Vishay"), disclaim any and all liability for any errors, inaccuracies or incompleteness contained in any datasheet or in any other disclosure relating to any product.

Vishay makes no warranty, representation or guarantee regarding the suitability of the products for any particular purpose or the continuing production of any product. To the maximum extent permitted by applicable law, Vishay disclaims (i) any and all liability arising out of the application or use of any product, (ii) any and all liability, including without limitation special, consequential or incidental damages, and (iii) any and all implied warranties, including warranties of fitness for particular purpose, non-infringement and merchantability.

Statements regarding the suitability of products for certain types of applications are based on Vishay's knowledge of typical requirements that are often placed on Vishay products in generic applications. Such statements are not binding statements about the suitability of products for a particular application. It is the customer's responsibility to validate that a particular product with the properties described in the product specification is suitable for use in a particular application. Parameters provided in datasheets and / or specifications may vary in different applications and performance may vary over time. All operating parameters, including typical parameters, must be validated for each customer application by the customer's technical experts. Product specifications do not expand or otherwise modify Vishay's terms and conditions of purchase, including but not limited to the warranty expressed therein.

Hyperlinks included in this datasheet may direct users to third-party websites. These links are provided as a convenience and for informational purposes only. Inclusion of these hyperlinks does not constitute an endorsement or an approval by Vishay of any of the products, services or opinions of the corporation, organization or individual associated with the third-party website. Vishay disclaims any and all liability and bears no responsibility for the accuracy, legality or content of the third-party website or for that of subsequent links.

Vishay products are not designed for use in life-saving or life-sustaining applications or any application in which the failure of the Vishay product could result in personal injury or death unless specifically qualified in writing by Vishay. Customers using or selling Vishay products not expressly indicated for use in such applications do so at their own risk. Please contact authorized Vishay personnel to obtain written terms and conditions regarding products designed for such applications.

No license, express or implied, by estoppel or otherwise, to any intellectual property rights is granted by this document or by any conduct of Vishay. Product names and markings noted herein may be trademarks of their respective owners.