

Ten Turns Servo or Bushing Mount Hall Effect Sensor in Size 09 (22.2 mm)



FEATURES

- All electrical angles available up to: 3600°
- Accurate linearity down to: $\pm 0.5\%$
- Very long life: 50M cycles for servo, 10M cycles for bushing
- Non contacting technology: Hall effect; true power on sensor
- Model dedicated to applications requiring long life
- Material categorization: For definitions of compliance please see www.vishay.com/doc?99912

RoHS
COMPLIANT

QUICK REFERENCE DATA	
Sensor type	Multi Turn ROTATIONAL, hall effect
Output type	Wires or rear turrets
Market appliance	Industrial
Dimensions	7/8" (22.2 mm)

ELECTRICAL SPECIFICATIONS		
PARAMETER	STANDARD	SPECIAL
Electrical angle	10 turns 3600°	Any other angle upon request
Linearity	$\pm 1\%$	$\pm 0.5\%$
Supply voltage	5 V _{DC} $\pm 10\%$	Other upon request
Supply current	< 16 mA for single	< 32 mA for redundant
Output signal	Analog ratiometric 1 % to 99 % of V _{supply} (other on request) or PWM 1 kHz, 10 % to 90 % duty cycle or SPI binary on 5 V or binary on 3.3 V	
Over voltage protection	+ 20 V _{DC}	
Reverse voltage protection	- 10 V _{DC}	
Load resistance recommended	Min. 1 k Ω for analog output and PWM output	
Hysteresis static	10° on drive shaft	

MECHANICAL SPECIFICATIONS	
PARAMETER	
Mechanical travel	3600° continuous
Bearing type	A sleeve bearing for bushing model/2 ball bearings for servo model
Standard	IP 50; other on request
Resolution	12 bits for analog and PWM, 14 bits for SPI

ORDERING INFORMATION/DESCRIPTION									
34 THE	B	1	A	T	A	2S22	XXXX	BO 1	e1
MODEL	MOUNTING TYPE	NUMBER OF SIGNALS	LINEARITY	OUTPUT TYPE	OUTPUT SIGNAL	SHAFT TYPE	SPECIAL REQUEST	PACKAGING	LEAD FINISH
	B: Bushing S: Servo	1: Single 2: Redundant	A: $\pm 1\%$ B: $\pm 0.5\%$	T: Turrets Z: Custom W: Wires	A: Analog CW B: Analog CCW C: PWM CW D: PWM CCW E: SPI CW ⁽¹⁾ F: SPI CCW ⁽¹⁾ G: Analog inverted slope H: PWM inverted slope K: SPI inverted slope ⁽¹⁾ Z: Other output	2: 3.175 mm 9: Special P: Plain S: Slotted Z: Other type		Box of 1 piece	
Shaft length from mounting face standard: 22 mm									

Note
⁽¹⁾ SPI output → output type: Wires

SAP PART NUMBERING GUIDELINES							
34 THE	S	2	B	T	C	2P12	XXXX
MODEL	SERVO TYPE	2 OUTPUT SIGNALS	LINEARITY	OUTPUT TYPE	OUTPUT SIGNAL	SHAFT TYPE	SPECIAL REQUEST
			B: $\pm 0.5\%$				

V_{OUT} ANALOG

Single Output (output signal code: "A")

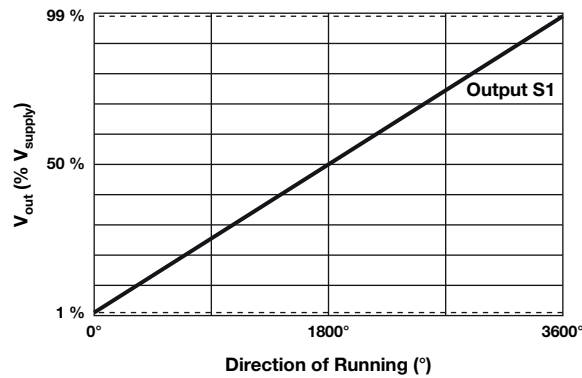

Redundant Output: with inverted slope
(output signal code: "G")

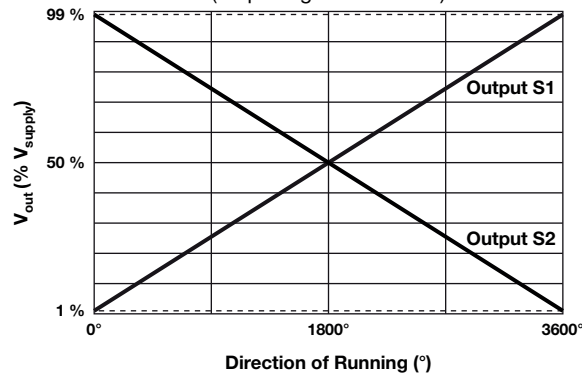

V_{OUT} PWM

Single Output: (output signal code: "C")

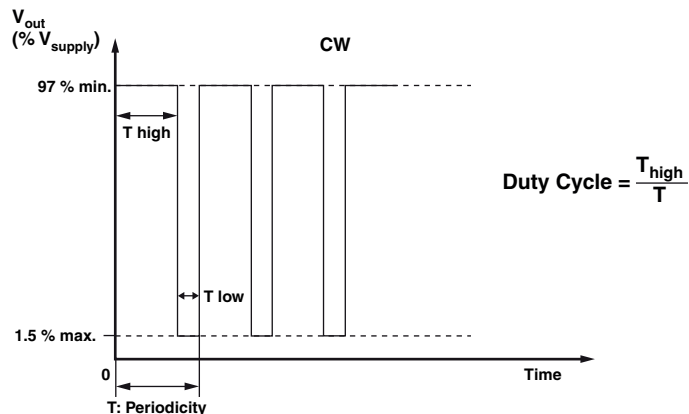

V_{OUT} SPI

Notice on demand

Output signal code: "E" if CW (single or redundant identical)

Output signal code: "F" if CCW (single or redundant identical)

Output signal code: "K" if CW (if redundant but inverted slope)



MECHANICAL SPECIFICATIONS		
PARAMETER	STANDARD	SPECIAL
Mounting type	Servo mounting type or bushing mount (delivered with nut and washer)	
Housing	Anodized aluminum	
Shaft guiding	2 ball bearings for servo and sleeve bearing for bushing	
Shaft	Stainless steel Ø 3.175	Other on request
Outputs	Turrets	Other on request
Mechanical travel	3600° and no stop	

ENVIRONMENTAL SPECIFICATIONS	
Operating temperature range	- 40 °C; + 85 °C
Life	> 10M of cycles for bushing > 50M of cycles for servo
Rotational speed (max.)	1200 rpm
Immunity to radiated electromagnetic disturbances	200 V/m 150 kHz/1 GHz, IEC 62132-2 part 2 (level A)
Immunity to power frequency magnetic field	200 A/m 50 Hz/60 Hz, EN 61000-4-8 (level A)
Radiated electromagnetic emissions	30 MHz/1 GHz < 30 dBµV/m, EN 61000-6-4 (level A)
Electrostatic discharges	Contact discharges: ± 4 kV Air discharges: ± 8 kV, EN 61000-4-2
Sine vibration on 3 axes	1.5 mm or 20 g from 10 Hz to 2000 Hz
Mechanical shocks on 3 axes	50 g, 11 ms, half sine



DIMENSIONS in millimeters

Drawing for bushing mount type: 34THEB...

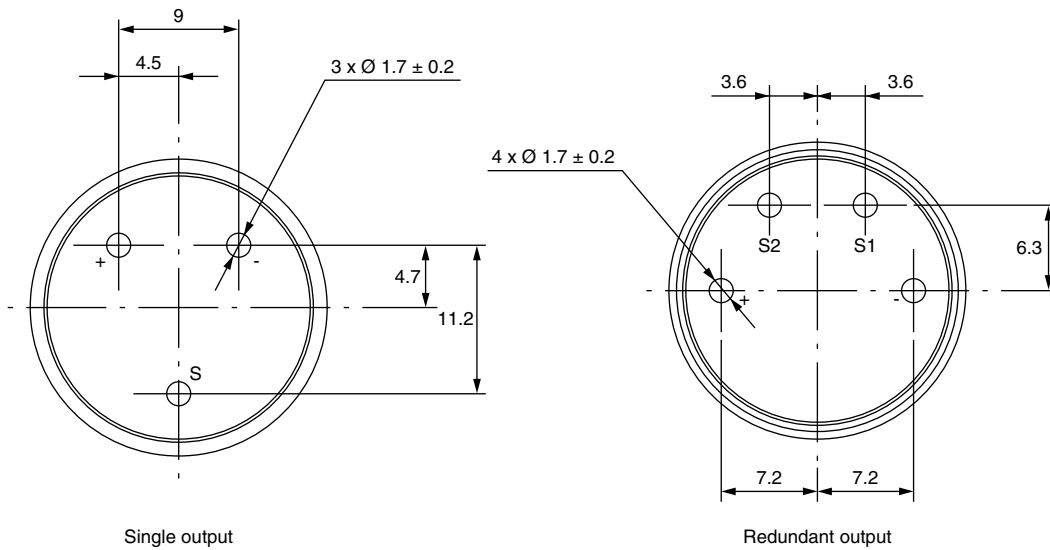
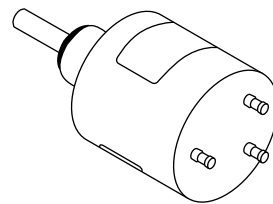
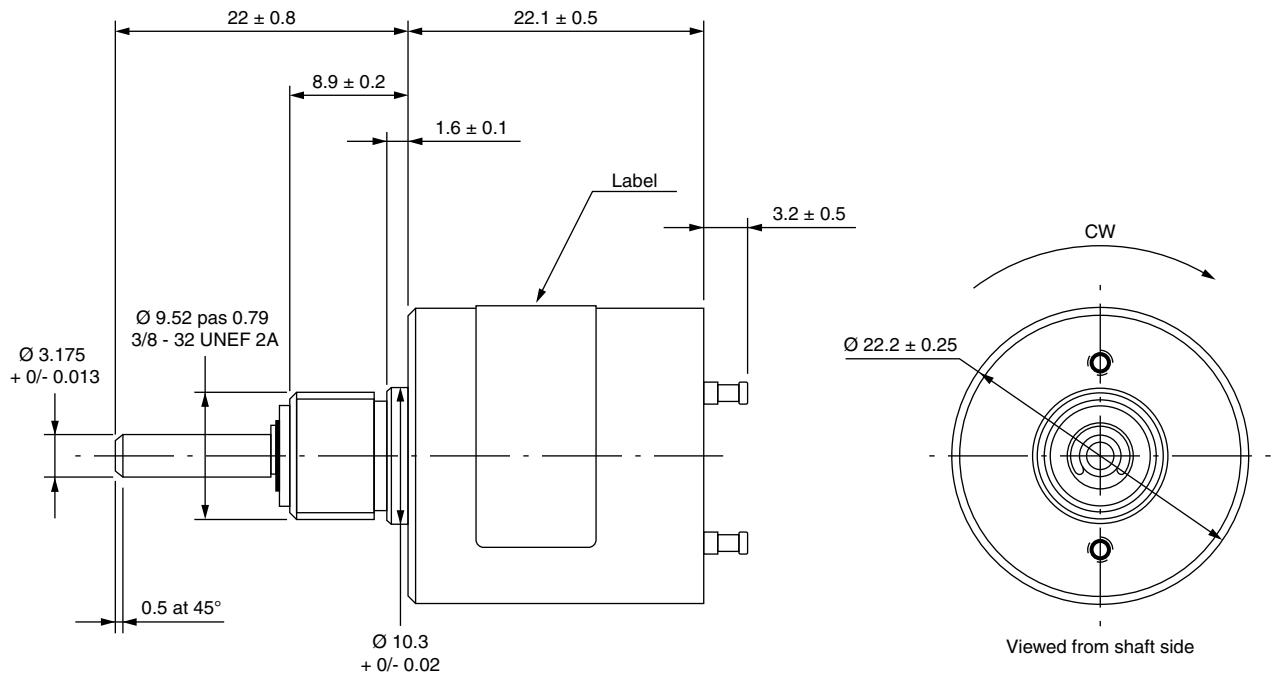



DIMENSIONS in millimeters

Drawing for servo mount type: 34THES...

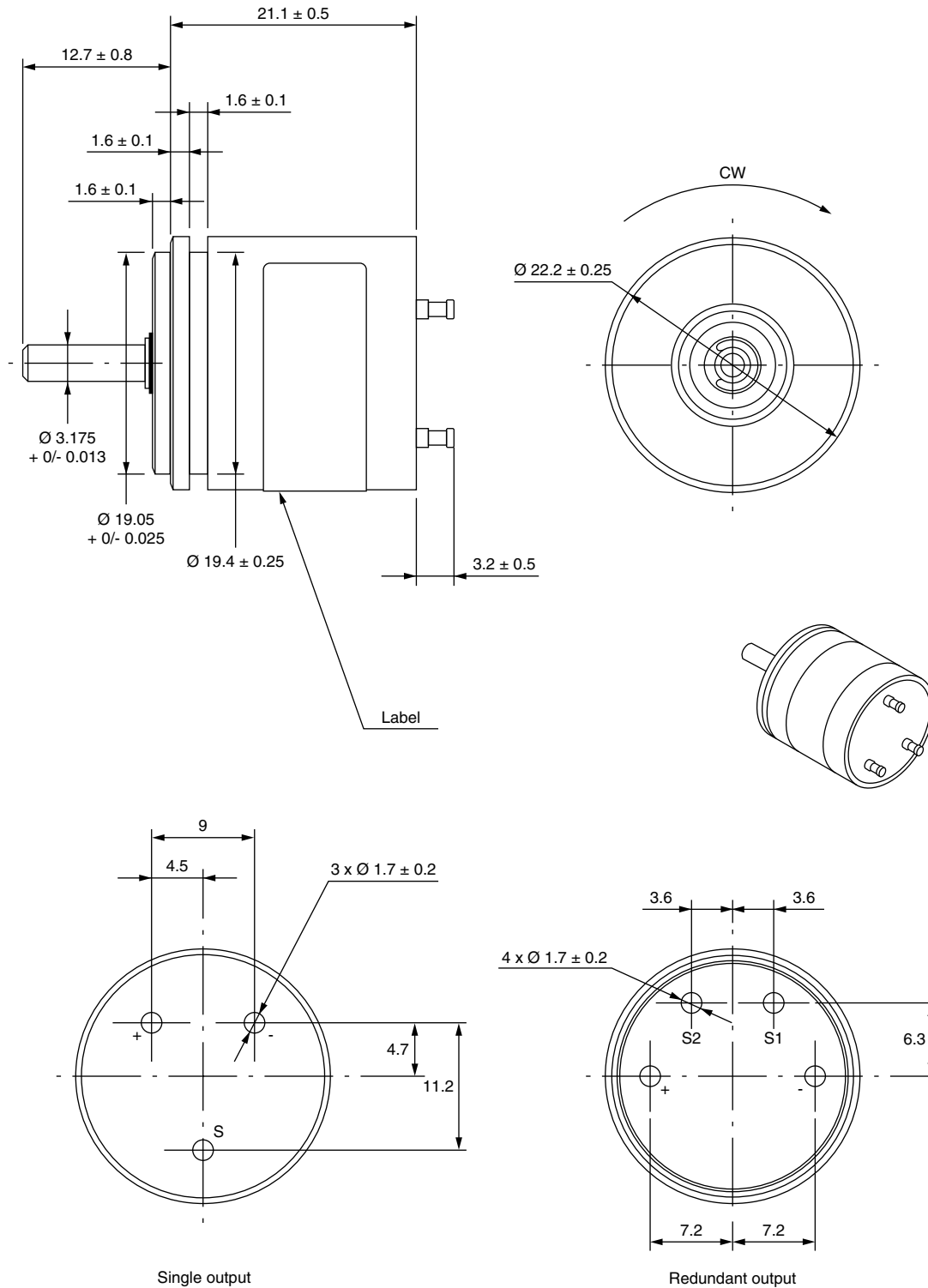

BUSHING AND SERVO TYPES

Output by wires for output signal "SPI" single and redundant

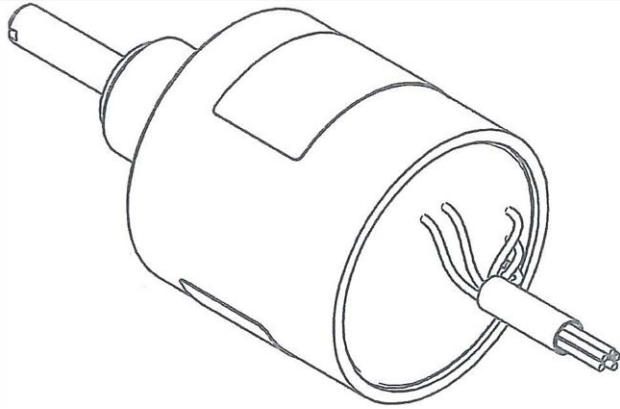

SINGLE SPI OUTPUT (servo and bushing)	
WIRE COLOR	OUTPUT
Yellow	GND (-)
Red	MOSI
Green	V _{CC} (+)
White	SS
Blue	SCLK

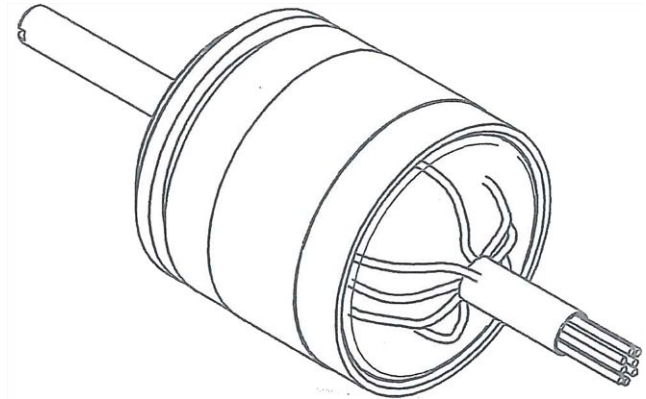

REDUNDANT SPI OUTPUT (servo and bushing)	
WIRE COLOR	OUTPUT
Black	V-
Red	V+
Yellow	O/I 1
Blue	CLK 1
White	/SS 1
Green	O/I 2
Violet	CLK 2
Grey	/SS 2



Disclaimer

ALL PRODUCT, PRODUCT SPECIFICATIONS AND DATA ARE SUBJECT TO CHANGE WITHOUT NOTICE TO IMPROVE RELIABILITY, FUNCTION OR DESIGN OR OTHERWISE.

Vishay Intertechnology, Inc., its affiliates, agents, and employees, and all persons acting on its or their behalf (collectively, "Vishay"), disclaim any and all liability for any errors, inaccuracies or incompleteness contained in any datasheet or in any other disclosure relating to any product.

Vishay makes no warranty, representation or guarantee regarding the suitability of the products for any particular purpose or the continuing production of any product. To the maximum extent permitted by applicable law, Vishay disclaims (i) any and all liability arising out of the application or use of any product, (ii) any and all liability, including without limitation special, consequential or incidental damages, and (iii) any and all implied warranties, including warranties of fitness for particular purpose, non-infringement and merchantability.

Statements regarding the suitability of products for certain types of applications are based on Vishay's knowledge of typical requirements that are often placed on Vishay products in generic applications. Such statements are not binding statements about the suitability of products for a particular application. It is the customer's responsibility to validate that a particular product with the properties described in the product specification is suitable for use in a particular application. Parameters provided in datasheets and / or specifications may vary in different applications and performance may vary over time. All operating parameters, including typical parameters, must be validated for each customer application by the customer's technical experts. Product specifications do not expand or otherwise modify Vishay's terms and conditions of purchase, including but not limited to the warranty expressed therein.

Hyperlinks included in this datasheet may direct users to third-party websites. These links are provided as a convenience and for informational purposes only. Inclusion of these hyperlinks does not constitute an endorsement or an approval by Vishay of any of the products, services or opinions of the corporation, organization or individual associated with the third-party website. Vishay disclaims any and all liability and bears no responsibility for the accuracy, legality or content of the third-party website or for that of subsequent links.

Vishay products are not designed for use in life-saving or life-sustaining applications or any application in which the failure of the Vishay product could result in personal injury or death unless specifically qualified in writing by Vishay. Customers using or selling Vishay products not expressly indicated for use in such applications do so at their own risk. Please contact authorized Vishay personnel to obtain written terms and conditions regarding products designed for such applications.

No license, express or implied, by estoppel or otherwise, to any intellectual property rights is granted by this document or by any conduct of Vishay. Product names and markings noted herein may be trademarks of their respective owners.