

## 50 A VRPower® Integrated Power Stage

### DESCRIPTION

The SiCQ670 is a high frequency integrated power stage optimized for synchronous buck applications to offer high current, high efficiency, and high power density performance with very low shutdown current. Packaged in Vishay's proprietary 5 mm x 5 mm MLP package, SiCQ670 enables voltage regulator designs to deliver up to 50 A continuous current per phase.

The internal power MOSFETs utilize Vishay's latest TrenchFET® technology that delivers industry benchmark performance to significantly reduce switching and conduction losses.

The SiCQ670 incorporates an advanced MOSFET gate driver IC that features high current driving capability, adaptive dead-time control, an integrated bootstrap switch, and user selectable zero current detection to improve light load efficiency. The driver is also compatible with a wide range of PWM controllers, supports tri-state PWM, and 5 V PWM logic.

The device also supports PS4 mode to reduce power consumption when the system is in standby state.

The SiCQ670 offers operating temperature monitoring, protection features, and warning flags that improve system monitoring and reliability.

### FEATURES

- AEC-Q100 qualified for automotive applications
- Highly efficient
  - Thermally enhanced PowerPAK® MLP55-31L package
  - Vishay's latest TrenchFET technology
  - Integrated, low impedance, bootstrap switch
  - Power MOSFETs optimized for 19 V input stage
  - Supports PS4 mode light load requirement with low shutdown supply current (5 V, 3  $\mu$ A)
  - Zero current detection for improved light load efficiency
- Highly versatile
  - 5 V PWM logic with tri-state and hold-off timer
  - 5 V DSBL#, ZCD\_EN# logic with PS4 state support
  - High frequency operation up to 2 MHz
- Robust and reliable
  - Delivers in excess of 50 A continuous current, 70 A, peak (10 ms) and 100 A, peak (10  $\mu$ s)
  - Over current protection
  - Over temperature flag
  - Over temperature protection
  - Under-voltage lockout protection
  - High side MOSFET short detection
- Effective monitoring and reporting
  - Accurate temperature reporting
  - Warnings and faults reporting flag
- Material categorization: for definitions of compliance please see [www.vishay.com/doc?99912](http://www.vishay.com/doc?99912)



### APPLICATIONS

- Multi-phase DC/DC converter for high power SoC and FPGA in:
  - Autonomous and ADAS driving module
  - Artificial intelligence acceleration or machine learning module
  - Cloud computing
  - Graphic processing unit (GPU)

### TYPICAL APPLICATION DIAGRAM

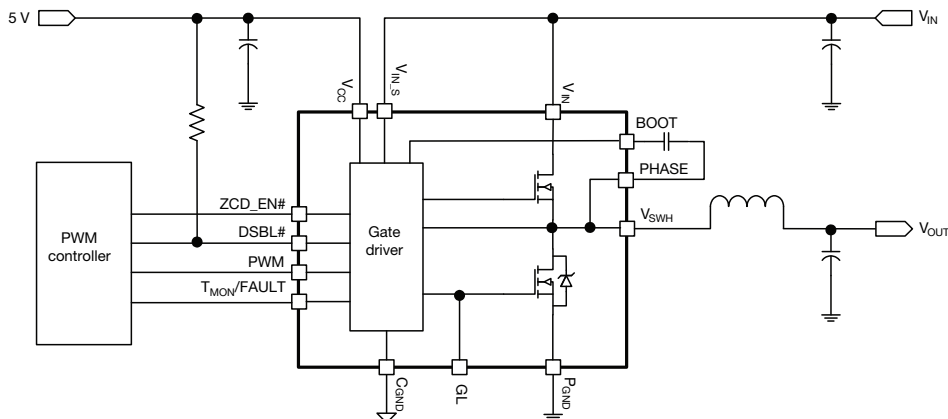
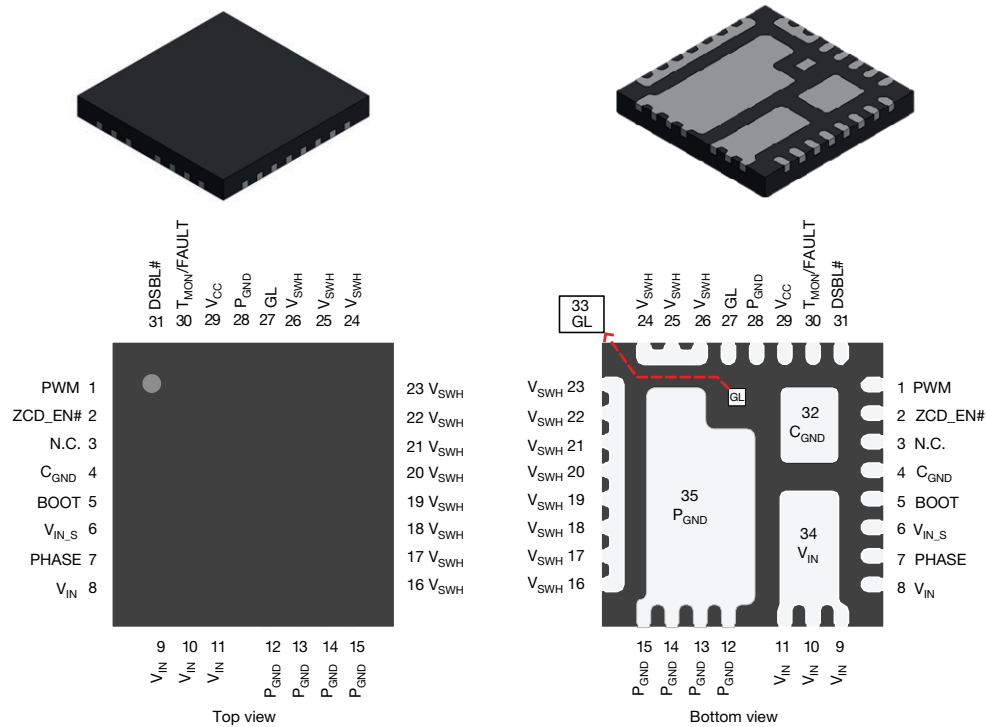
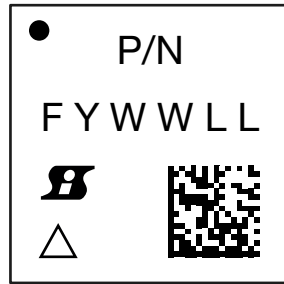

Fig. 1 - Typical Application Diagram

**PINOUT CONFIGURATION**

**Fig. 2 - Pin Configuration**

PIN CONFIGURATION		
PIN NUMBER	NAME	FUNCTION
1	PWM	PWM input
2	ZCD_EN#	The ZCD_EN# pin enables or disables diode emulation. When ZCD_EN# is LOW, diode emulation is allowed. When ZCD_EN# is HIGH, continuous conduction mode is forced. ZCD_EN# can also be put in a high impedance mode by floating the pin. If ZCD_EN# is floating, the device shuts down and consumes typically 3 $\mu$ A (10 $\mu$ A max.) current.
3	N.C.	Not connected
5	BOOT	High side driver bootstrap voltage
4, 32	C <sub>GND</sub>	Analog ground
6	V <sub>IN_S</sub>	Over current protection input voltage, connect this pin to power stage input voltage
7	PHASE	Return path of high side gate driver
8 to 11, 34	V <sub>IN</sub>	Power stage input voltage. Drain of high side MOSFET
12 to 15, 28, 35	P <sub>GND</sub>	Power ground
16 to 26	V <sub>SWH</sub>	Phase node of the power stage
27, 33	GL	Low side MOSFET gate signal
29	V <sub>CC</sub>	Supply voltage
30	T <sub>MON</sub> /FAULT	Temperature monitor output, FAULT flag output
31	DSBL#	Disable input, active low

ORDERING INFORMATION			
PART NUMBER	PACKAGE	MARKING CODE	OPTION
SiCQ670CD-T1-GE3	PowerPAK MLP55-31L	CQ670	5 V PWM optimized
SiCQ670DB	Reference board		

**PART MARKING INFORMATION**

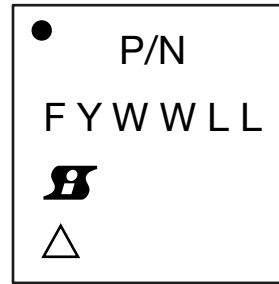
Marking with 2D code



Marking without 2D code

- = pin 1 indicator
- P/N = part number code
- B** = Siliconix logo
- △ = ESD symbol
- F = assembly factory code
- Y = year code
- WW = week code
- LL = lot code
- = 2D code

<b>ABSOLUTE MAXIMUM RATINGS</b>			
<b>ELECTRICAL PARAMETER</b>	<b>SYMBOL</b>	<b>LIMIT</b>	<b>UNIT</b>
Input voltage	$V_{IN}, V_{IN,S}$	-0.3 to +28	V
Control logic supply voltage	$V_{CC}$	-0.3 to +7	
Switch node (DC voltage)	$V_{SWH}$	-0.3 to +28	
Switch node (AC voltage) <sup>(1)</sup>		-7 to +35	
BOOT voltage (DC voltage)	$V_{BOOT}$	33	
BOOT voltage (AC voltage) <sup>(2)</sup>		40	
BOOT to PHASE (DC voltage)	$V_{BOOT-PHASE}$	-0.3 to +7	
BOOT to PHASE (AC voltage) <sup>(3)</sup>		-0.3 to +8	
All logic inputs and outputs	PWM, ZCD_EN#, DSBL#, T <sub>MON</sub> /FAULT	-0.3 to $V_{CC} + 0.3$	
Max. operating junction temperature	$T_J$	150	
Ambient temperature	$T_A$	-40 to +125	
Storage temperature	$T_{stg}$	-65 to +150	
Electrostatic discharge protection	Human body model, JESD22-A114	2000	V
	Charged device model, JESD22-C101	1000	

**Notes**

- Stresses beyond those listed under “Absolute Maximum Ratings” may cause permanent damage to the device. These are stress ratings only, and functional operation of the device at these or any other conditions beyond those indicated in the operational sections of the specifications is not implied. Exposure to absolute maximum rating conditions for extended periods may affect device reliability
- <sup>(1)</sup> The specification values indicated “AC” is  $V_{SWH}$  to P<sub>GND</sub> -7 V (< 20 ns, 10 μJ), min. and 35 V (< 50 ns), max.
- <sup>(2)</sup> The specification value indicates “AC voltage” is  $V_{BOOT}$  to P<sub>GND</sub>, 40 V (< 50 ns) max.
- <sup>(3)</sup> The specification value indicates “AC voltage” is  $V_{BOOT}$  to  $V_{PHASE}$ , 8 V (< 50 ns) max.

<b>RECOMMENDED OPERATING RANGE</b>				
<b>ELECTRICAL PARAMETER</b>	<b>MINIMUM</b>	<b>TYPICAL</b>	<b>MAXIMUM</b>	<b>UNIT</b>
Input voltage ( $V_{IN}$ )	2.5	-	24	V
Control logic supply voltage ( $V_{CC}$ )	4.5	5	5.5	
BOOT to PHASE ( $V_{BOOT-PHASE}$ , DC voltage)	4	4.5	5.5	
Thermal resistance from junction to ambient	-	10.6	-	°C/W
Thermal resistance from junction to case	-	1.6	-	



<b>ELECTRICAL SPECIFICATIONS</b>						
(ZCD_EN# = 5 V, V <sub>IN</sub> = 12 V, V <sub>CC</sub> = 5 V, DSBL# = 5 V, T <sub>A</sub> = 25 °C, unless otherwise stated)						
PARAMETER	SYMBOL	TEST CONDITION	LIMITS			UNIT
			MIN.	TYP.	MAX.	
<b>POWER SUPPLY</b>						
Control logic supply current	I <sub>VCC</sub>	V <sub>PWM</sub> = FLOAT	-	80	-	μA
Drive supply current		V <sub>PWM</sub> = FLOAT, V <sub>ZCD_EN#</sub> = 0 V	-	120	-	mA
		f <sub>S</sub> = 300 kHz, D = 0.1	-	10.3	20	
		f <sub>S</sub> = 1 MHz, D = 0.1	-	30	-	
PS4 mode supply current	I <sub>VCC</sub>	V <sub>PWM</sub> = V <sub>ZCD_EN#</sub> = FLOAT, T <sub>A</sub> = -10 °C to +100 °C	-	3	6	μA
Disabled mode supply current		DSBL# = 0 V	-	3	9	
<b>BOOTSTRAP SUPPLY</b>						
Bootstrap switch R <sub>DS(on)</sub>	R <sub>BS</sub>	V <sub>CC</sub> = 5 V	-	3	-	Ω
<b>DSBL# CONTROL INPUT</b>						
DSBL# logic input voltage	V <sub>IH_DSBL#</sub>	Input logic high	2	-	-	V
	V <sub>IL_DSBL#</sub>	Input logic low	-	-	0.8	
DSBL# input current	I <sub>DSBL#</sub>	V <sub>DSBL#</sub> = 5 V	-	0.25	1	μA
<b>PWM CONTROL INPUT (SiC670)</b>						
Rising threshold	V <sub>TH_PWM_R</sub>	V <sub>PWM</sub> = FLOAT	4.2	-	-	V
Falling threshold	V <sub>TH_PWM_F</sub>		-	-	0.72	
Tri-state voltage	V <sub>TRI</sub>		-	2.5	-	
Tri-state rising threshold	V <sub>TRI_TH_R</sub>		1.6	-	-	
Tri-state falling threshold	V <sub>TRI_TH_F</sub>		-	-	3.4	
Tri-state rising threshold hysteresis	V <sub>HYS_TRI_R</sub>		-	325	-	mV
Tri-state falling threshold hysteresis	V <sub>HYS_TRI_F</sub>	-	225	-		
PWM input current	I <sub>PWM</sub>	V <sub>PWM</sub> = 5 V	-	-	350	μA
		V <sub>PWM</sub> = 0 V	-	-	-350	
<b>ZCD_EN# CONTROL INPUT</b>						
Rising threshold	V <sub>TH_ZCD_EN#_R</sub>	V <sub>ZCD_EN#</sub> = FLOAT	4.0	-	-	V
Falling threshold	V <sub>TH_ZCD_EN#_F</sub>		-	-	1.1	
Tri-state voltage	V <sub>TRI_ZCD_EN#</sub>		-	2.5	-	
Tri-state rising threshold	V <sub>TRI_ZCD_EN#_R</sub>		2.1	-	-	
Tri-state falling threshold	V <sub>TRI_ZCD_EN#_F</sub>		-	-	2.9	
Tri-state rising threshold hysteresis	V <sub>HYS_TRI_ZCD#_R</sub>		-	600	-	mV
Tri-state falling threshold hysteresis	V <sub>HYS_TRI_ZCD#_F</sub>	-	450	-		
ZCD_EN# input current	I <sub>ZCD_EN#</sub>	V <sub>ZCD_EN#</sub> = 5 V	-	-	100	μA
		V <sub>ZCD_EN#</sub> = 0 V	-	-	-100	



<b>ELECTRICAL SPECIFICATIONS</b>						
(ZCD_EN# = 5 V, V <sub>IN</sub> = 12 V, V <sub>CC</sub> = 5 V, DSBL# = 5 V, T <sub>A</sub> = 25 °C, unless otherwise stated)						
PARAMETER	SYMBOL	TEST CONDITION	LIMITS			UNIT
			MIN.	TYP.	MAX.	
<b>TIMING SPECIFICATIONS</b>						
Tri-state to GH/GL rising propagation delay	t <sub>PD_TRI_R</sub>	No load, see fig. 4	-	60	-	ns
Tri-state hold-off time	t <sub>TSHO</sub>		-	45	-	
GH - turn off propagation delay	t <sub>PD_OFF_GH</sub>		-	15	-	
GH - turn on propagation delay (dead time rising)	t <sub>PD_ON_GH</sub>		-	30	-	
GL - turn off propagation delay	t <sub>PD_OFF_GL</sub>		-	25	-	
GL - turn on propagation delay (dead time falling)	t <sub>PD_ON_GL</sub>		-	110	-	
PWM minimum on-time	t <sub>PWM_ON_MIN.</sub>		-	17	-	
PS4 exit latency	t <sub>PS4EXIT</sub>	-	-	5.5	µs	
<b>UNDER VOLTAGE LOCKOUT</b>						
V <sub>CC</sub> under voltage lockout	V <sub>UVLO</sub>	V <sub>CC</sub> rising, on threshold	-	3.8	4	V
		V <sub>CC</sub> falling, off threshold	3.4	3.6	-	
V <sub>CC</sub> under voltage lockout hysteresis	V <sub>UVLO_HYST</sub>		-	300	-	mV
V <sub>BOOT</sub> under voltage lockout	V <sub>BOOT_UVLO</sub>	V <sub>BOOT</sub> rising, on threshold	-	3.6	3.8	V
		V <sub>BOOT</sub> falling, off threshold	3.2	3.4	-	
V <sub>BOOT</sub> under voltage lockout hysteresis	V <sub>BOOT_UVLO_HYS_T</sub>		-	200	-	mV
<b>THERMAL MONITOR AND FAULT FLAG</b>						
Gain	TOUT <sub>GAIN</sub>		-	8	-	mV/°C
Offset voltage at 0 °C	V <sub>OFF_0C</sub>		0.4	0.6	0.8	V
TOUT range 125 °C (temp reporting)	TOUT <sub>125C</sub>		1.4	-	1.836	
FAULT mode	FAULT <sub>HIGH</sub>		2.4	-	3.6	
FAULT drive current	FAULT <sub>DRIVE</sub>		-	80	-	mA
<b>PROTECTIONS</b>						
Over current protection	I <sub>OCP</sub>		90	100	-	A
Over temperature protection	T <sub>SHDN</sub>		-	165	-	°C

**Notes**

- (1) Typical limits are established by characterization and are not production tested  
(2) Guaranteed by design

## DETAILED OPERATIONAL DESCRIPTION

### DSBL# Input, Enable Function

The DSBL# pin shuts down the driver and disables both high side and low side MOSFETs. In this state, standby current is minimized. When DSBL# is low, both PWM and ZCD\_EN# internal dividers are disconnected to reduce current consumption. If DSBL# is left unconnected, an internal pull-down resistor will pull the pin to  $C_{GND}$  and shut down the SiCQ670.

### PWM Input with Tri-state Function

The PWM input receives the PWM control signal from the VR controller IC. The PWM input is designed to be compatible with standard controllers using two state logic (H and L) and advanced controllers that incorporate tri-state logic (H, L and tri-state) on the PWM output. For two state logic, the PWM input operates as follows. When PWM is driven above  $V_{TH\_PWM\_R}$  the low side is turned OFF and the high side is turned ON. When PWM input is driven below  $V_{TH\_PWM\_F}$  the high side is turned OFF and the low side is turned ON. For tri-state logic, the PWM input operates as previously stated for driving the MOSFETs when PWM is logic high and logic low. However, there is a third state that is entered as the PWM output of a tri-state compatible controller enters its high impedance state. The high impedance state of the controller's PWM output allows the SiCQ670 to pull the PWM input into the tri-state region (see definition of PWM logic and tri-state, fig. 4). If the PWM input stays in this region for the tri-state hold-off period,  $t_{TSHO}$ , both high side and low side MOSFETs are turned OFF. The function allows the VR phase to be disabled without negative output voltage swing caused by inductor ringing and saves a Schottky diode clamp. The PWM and tri-state regions are separated by hysteresis to prevent false triggering. The SiCQ670 incorporates PWM voltage thresholds that are compatible with 5 V logic.

### Diode Emulation Mode and PS4 Mode (ZCD\_EN#)

The ZCD\_EN# pin enables or disables diode emulation mode. When ZCD\_EN# is driven below  $V_{TH\_ZCD\_EN\#\_F}$ , diode emulation is allowed. When ZCD\_EN# is driven above  $V_{TH\_ZCD\_EN\#\_R}$ , continuous conduction mode is forced. Diode emulation mode allows for higher converter efficiency under light load situations. With diode emulation active, the SiCQ670 will detect the zero current crossing of the output inductor and turn off the low side MOSFET. This ensures that discontinuous conduction mode (DCM) is achieved. Diode emulation is asynchronous to the PWM signal, therefore, the SiCQ670 will respond to the ZCD\_EN# input immediately after it changes state.

The ZCD\_EN# pin can be floated resulting in a high impedance state. The SiCQ670 will pull a floated ZCD\_EN# to the internally set tri-state level. A tri-state ZCD\_EN# combined with a tri-stated PWM output will shut down the SiCQ670, reducing current consumption to typically 3  $\mu$ A. This is an important feature in achieving the low standby current required in the PS4 state in ultrabooks and notebooks.

### Voltage Input ( $V_{IN}$ )

This is the power input to the drain of the high side power MOSFET. This pin is connected to the high power intermediate BUS rail.

### Switch Node ( $V_{SWH}$ and PHASE)

The switch node,  $V_{SWH}$ , is the power stage output. This is the output applied to the power inductor and output filter to deliver the output for the buck converter. The PHASE pin is internally connected to the switch node  $V_{SWH}$ . This pin is to be used exclusively as the return pin for the BOOT capacitor.

### Ground Connections ( $C_{GND}$ and $P_{GND}$ )

$P_{GND}$  (power ground) should be externally connected to  $C_{GND}$  (control analog ground). The layout of the printed circuit board should be such that the inductance separating  $C_{GND}$  and  $P_{GND}$  is minimized. Transient differences due to inductance effects between these two pins should not exceed 0.5 V

### Control and Drive Supply Voltage Input ( $V_{CC}$ )

$V_{CC}$  is the bias supply for the control IC and for the gate drivers.

### Bootstrap Circuit (BOOT)

A bootstrap switch and an external bootstrap capacitor form a charge pump that supplies voltage to the BOOT pin. An integrated bootstrap switch is incorporated so that only an external capacitor is necessary to complete the bootstrap circuit. Connect a bootstrap capacitor with one leg tied to BOOT pin and the other tied to PHASE pin.

### Shoot-Through Protection and Adaptive Dead Time

The SiCQ670 has an internal adaptive logic to avoid shoot-through and optimize dead time. The shoot-through protection ensures that both high side and low side MOSFETs are not turned ON at the same time. The adaptive dead time control operates as follows. The high side and low side gate voltages are monitored to prevent one from turning ON until the other gate voltage is sufficiently low (< 1 V). Built-in delays also ensure that one power MOS is completely OFF, before the other can be turned ON. This feature helps to adjust dead time as gate transitions change with respect to output current and temperature.

### Under Voltage Lockout (UVLO)

During the start up cycle the UVLO disables the gate drive, holding high side and low side MOSFET gates low until the supply voltage has reached a point at which the logic circuitry can be safely activated. The SiCQ670 also incorporates logic to clamp the gate drive signals to zero when the UVLO falling edge triggers the shutdown of the device.

**T<sub>MON</sub>/FAULT Temperature Monitor and Fault Flag Functions**

The T<sub>MON</sub>/FAULT output is used to report operating conditions detected by the logic of the driver that require attention.

A fault is reported by the T<sub>MON</sub>/FAULT output going high to 3.3 V.

The reported conditions are high temperature, insufficient bootstrap voltage, persistent over-current, and high side MOSFET short.

The T<sub>MON</sub>/FAULT output also reports the operating temperature of the SiCQ670.

The temperature is converted to a voltage with a conversion gain of 8 mV/°C and a target value of 600 mV at 0 °C.

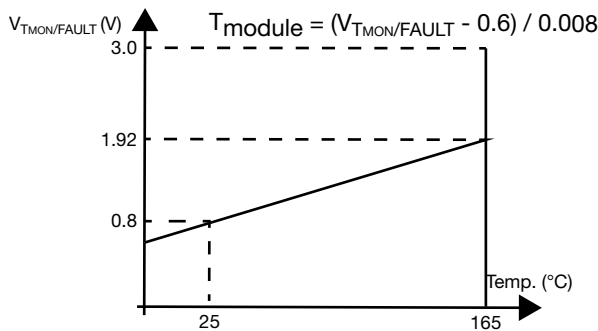

In a multi-phase topology, all T<sub>MON</sub>/FAULT signals are connected to the PWM controller and will indicate the temp. of the warmest device.

For proper operation, the T<sub>MON</sub> output must be biased with a resistor to ground. A 1 kΩ resistor is recommended.

The SiCQ670 also has an over temperature shutdown feature that stops operation when the temperature is above 165 °C.

The over temperature shutdown fault is reset by DISBL# cycling or power cycling.

**Over Current Protection Function**

The SiCQ670 is equipped with over-current protection.

An over-current condition will also be reported through the T<sub>MON</sub>/FAULT flag. The flag is automatically reset after 128 switching cycles that do not trigger the protection.

When the output current exceeds safe operating levels, the SiCQ670 will protect the power devices by forcing an early termination of the high side conduction time and skipping PWM pulses as needed.

**High Side MOSFET Short Detection**

A failure of the high side MOSFET may cause significant system damage. For this reason, the SiCQ670 monitors the switch node (PHASE) cycle by cycle in order to promptly detect a short of the high side power device.

After four consecutive HS short condition cycles are detected, the SiCQ670 will report the fault with the T<sub>MON</sub>/FAULT flag, and will ignore the incoming PWM signal. The low side MOSFET is turned on to channel away the current and protect the load from high input voltage.

The fault flag can only be reset by cycling power to the driver's logic.

**FUNCTIONAL BLOCK DIAGRAM**

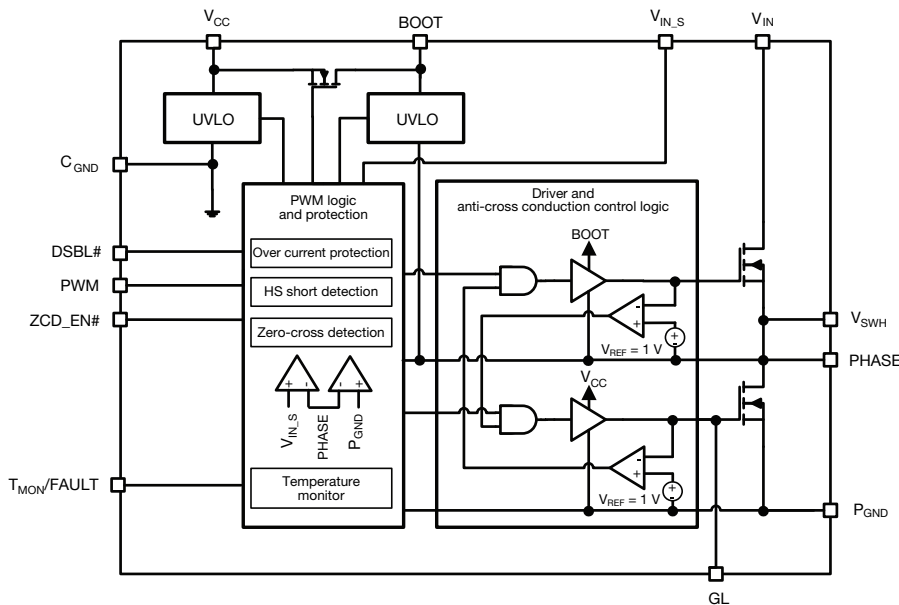

Fig. 3 - Functional Block Diagram

DEVICE TRUTH TABLE				
DSBL#	ZCD_EN#	PWM	GH	GL
L	X	X	L	L
H	Tri-state	X	L	L
H	L	L	L	H, $I_L > 0 A$ L, $I_L < 0 A$
H	L	H	H	L
H	L	Tri-state	L	L
H	H	L	L	H
H	H	H	H	L
H	H	Tri-state	L	L

**PWM TIMING DIAGRAM**

Fig. 4 - Definition of PWM Logic and Tri-state

**ZCD\_EN# - PS4 EXIT TIMING**

Fig. 5 - ZCD\_EN# - PS4 Exit Timing

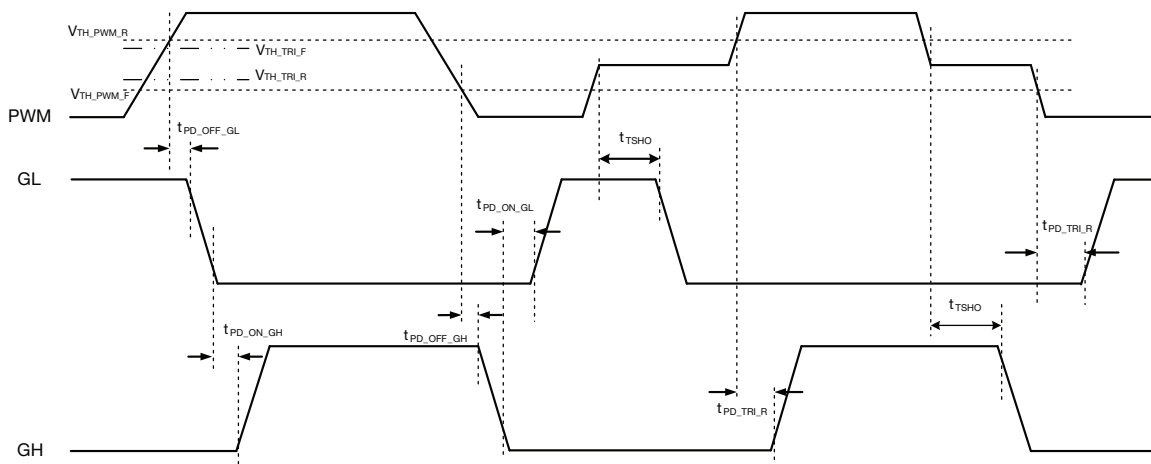

**ELECTRICAL CHARACTERISTICS**

Test condition:  $V_{IN} = 12\text{ V}$  (unless otherwise stated),  $V_{CC} = 5\text{ V}$ ,  $ZCD\_EN\# = 5\text{ V}$ ,  $DSBL\# = 5\text{ V}$ ,  $V_{OUT} = 1.05\text{ V}$ ,  $L_{OUT} = 220\text{ nH}$  ( $DCR = 0.29\text{ m}\Omega$ ),  $T_A = 25\text{ }^\circ\text{C}$ , natural convection cooling (all power loss and normalized power loss curves show SiCQ670 losses only unless otherwise stated)

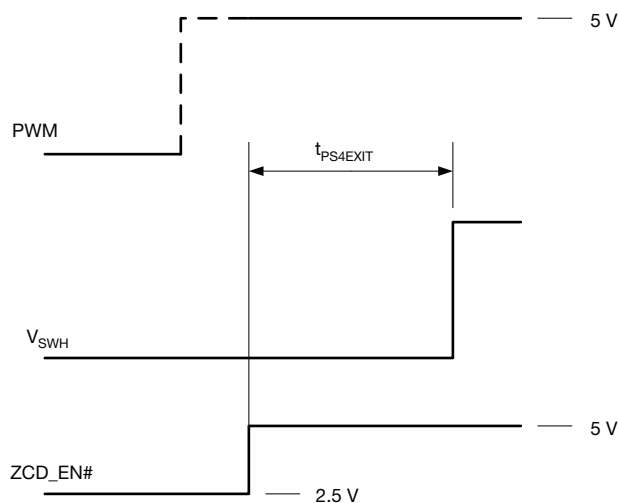
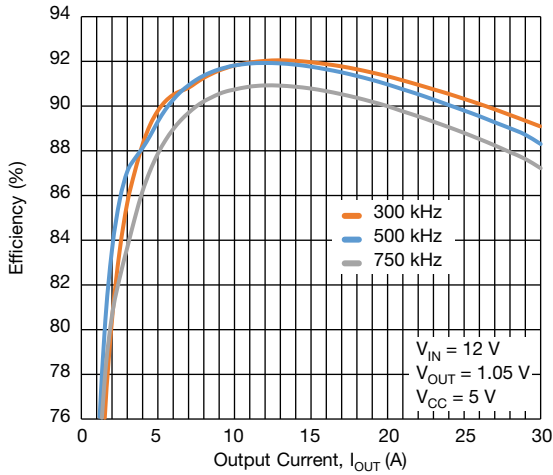

**Fig. 6 - Efficiency vs. Output Current ( $V_{IN} = 12\text{ V}$ )**

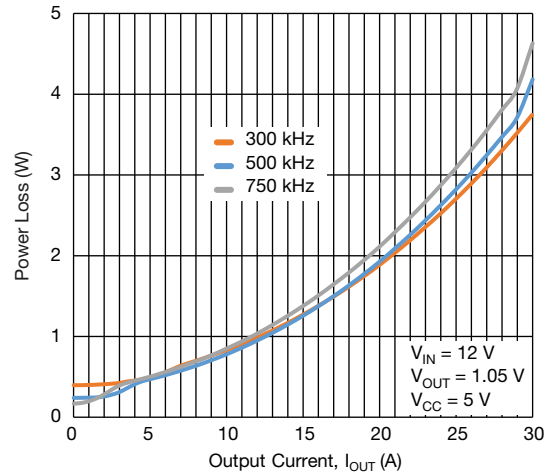

**Fig. 9 - Power Loss vs. Output Current ( $V_{IN} = 12\text{ V}$ )**

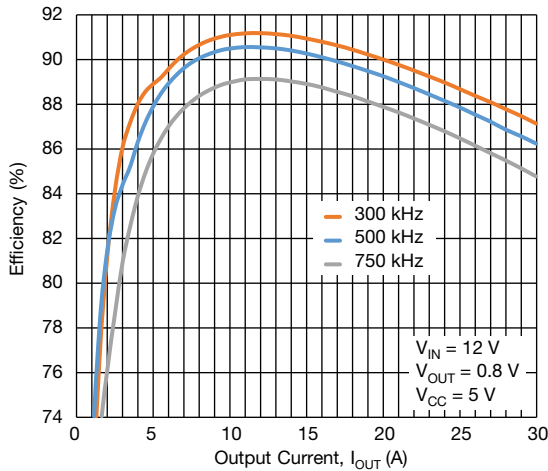

**Fig. 7 - Efficiency vs. Output Current ( $V_{IN} = 12\text{ V}$ )**

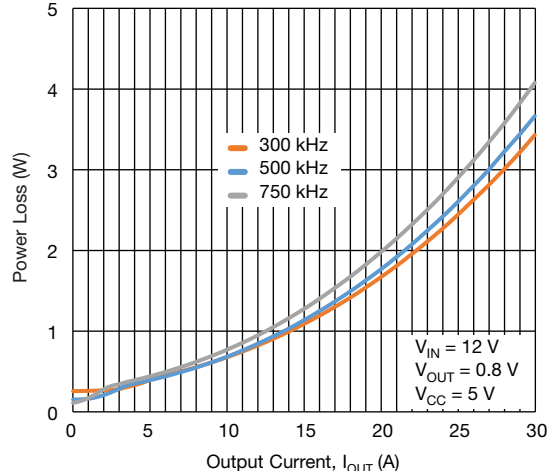

**Fig. 10 - Power Loss vs. Output Current ( $V_{IN} = 12\text{ V}$ )**

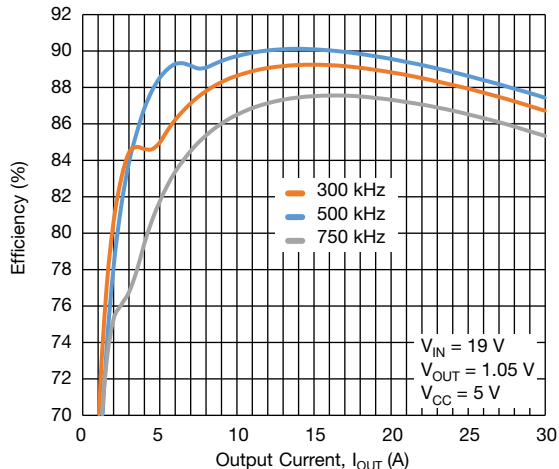

**Fig. 8 - Efficiency vs. Output Current ( $V_{IN} = 19\text{ V}$ )**

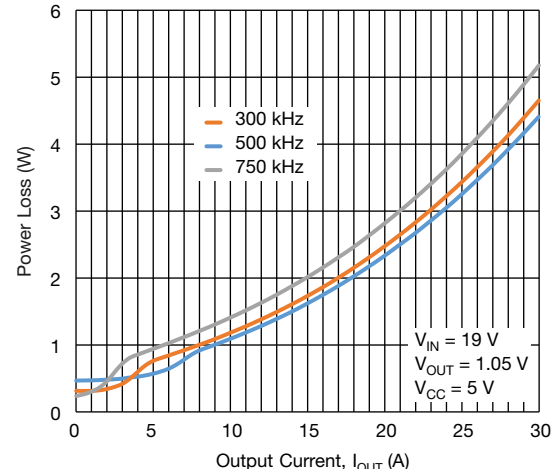

**Fig. 11 - Power Loss vs. Output Current ( $V_{IN} = 19\text{ V}$ )**

**ELECTRICAL CHARACTERISTICS**

Test condition:  $V_{IN} = 13\text{ V}$  (unless otherwise stated),  $V_{CC} = 5\text{ V}$ ,  $ZCD\_EN\# = 5\text{ V}$ ,  $DSBL\# = 5\text{ V}$ ,  $V_{OUT} = 1.05\text{ V}$ ,  $L_{OUT} = 220\text{ nH}$  ( $DCR = 0.29\text{ m}\Omega$ ),  $T_A = 25\text{ }^\circ\text{C}$ , natural convection cooling (all power loss and normalized power loss curves show SiCQ670 losses only unless otherwise stated)

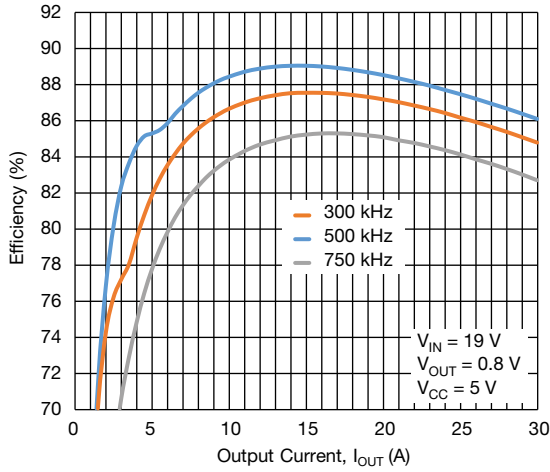

**Fig. 12 - Efficiency vs. Output Current ( $V_{IN} = 19\text{ V}$ )**

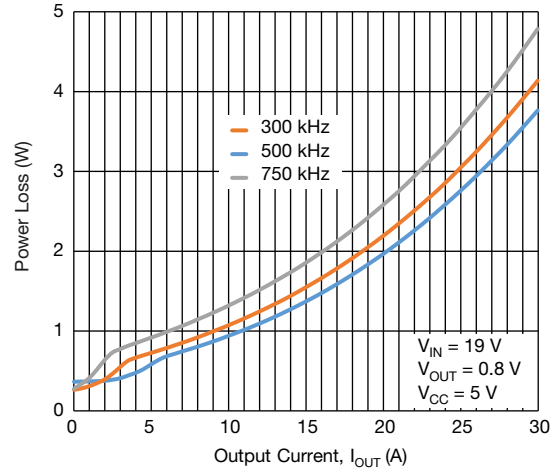

**Fig. 15 - Power Loss vs. Output Current ( $V_{IN} = 19\text{ V}$ )**

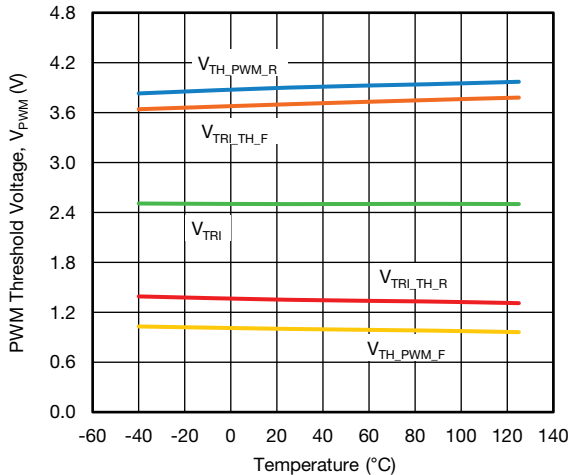

**Fig. 13 - PWM Threshold vs. Temperature**

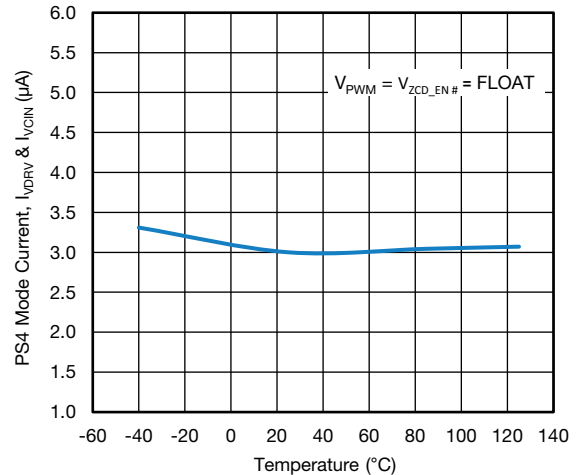

**Fig. 16 - PS4 Mode Current vs. Temperature**

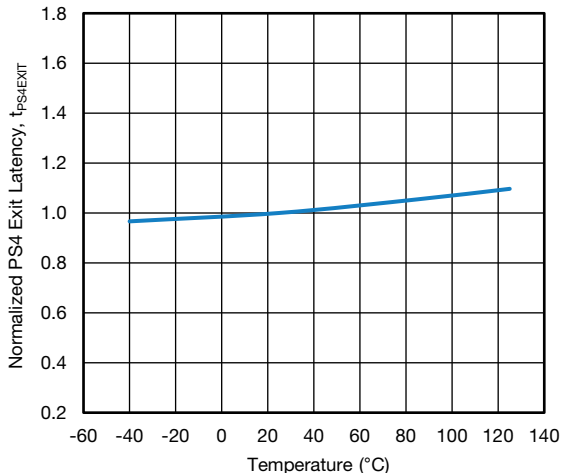

**Fig. 14 - PS4 Exit Latency vs. Temperature**

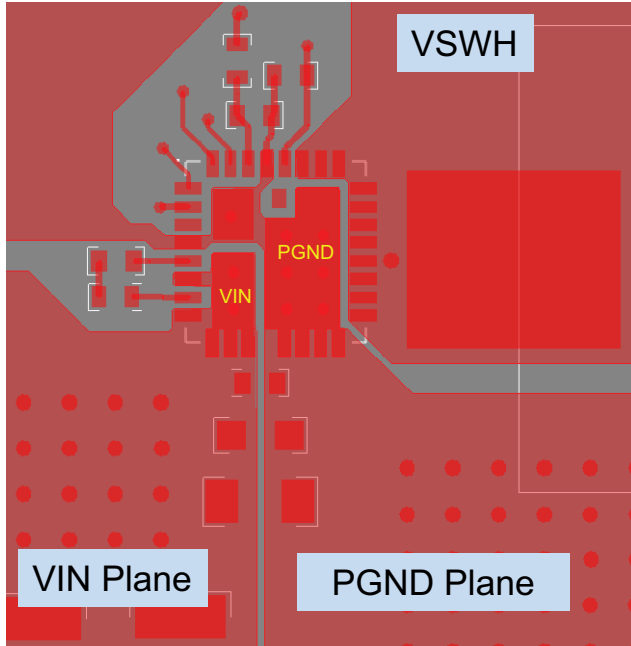
**PCB LAYOUT RECOMMENDATIONS**
**Step 1:  $V_{IN}$  / GND Planes and Decoupling**

1. Layout  $V_{IN}$  and  $P_{GND}$  planes as shown above
2. Ceramic capacitors should be placed right between  $V_{IN}$  and  $P_{GND}$ , and very close to the device for best decoupling effect
3. Different values / packages of ceramic capacitors should be used to cover entire decoupling spectrum e.g. 1210, 0805, 0603 and 0402
4. Lower-valued capacitors should be placed closer to  $V_{IN}$  pin(s) for better high frequency noise decoupling.

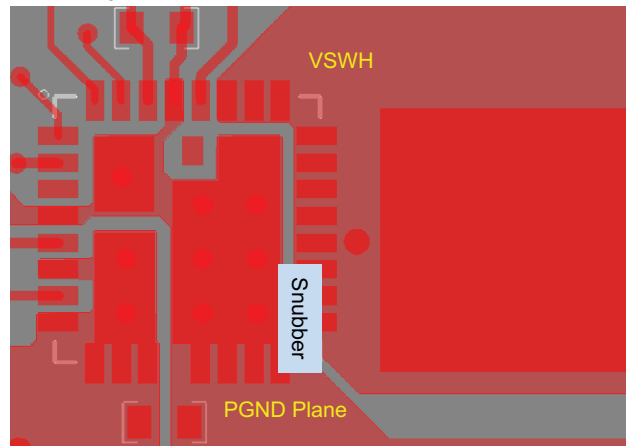
**Step 2:  $V_{SWH}$  Plane**

1. Connect output inductor to DrMOS with wide plane to lower the resistance
2. If any snubber network is required, place the components as shown above and the network can be placed at bottom

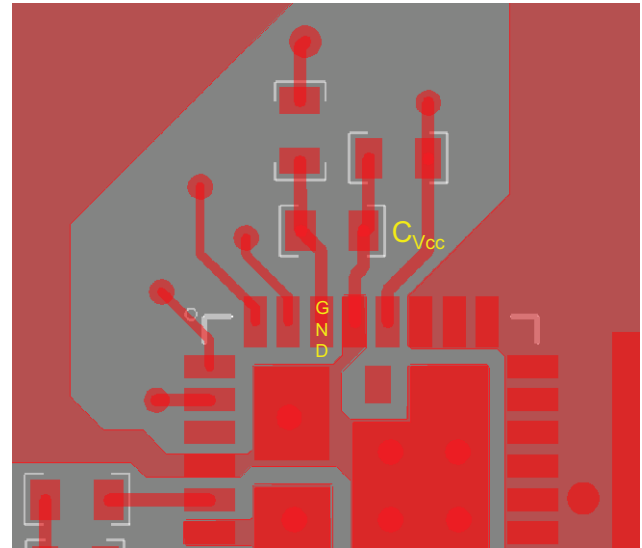
**Step 3:  $V_{CIN}$  /  $V_{DRV}$  Input Filter**

1. The  $V_{CC}$  input filter ceramic cap should be placed very close to DrMOS
2.  $C_{VCC}$  cap should be placed between pin 28 ( $P_{GND}$  of driver IC) and pin 29 to provide maximum instantaneous driver current for low side MOSFET during switching cycle

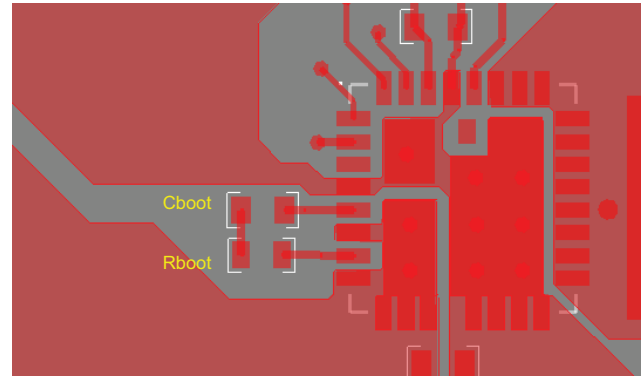
**Step 4: BOOT Resistor and Capacitor Placement**

1. These components need to be placed very close to the device, right between PHASE (pin 7) and BOOT (pin 5)
2. To reduce parasitic inductance, chip size 0402 can be used

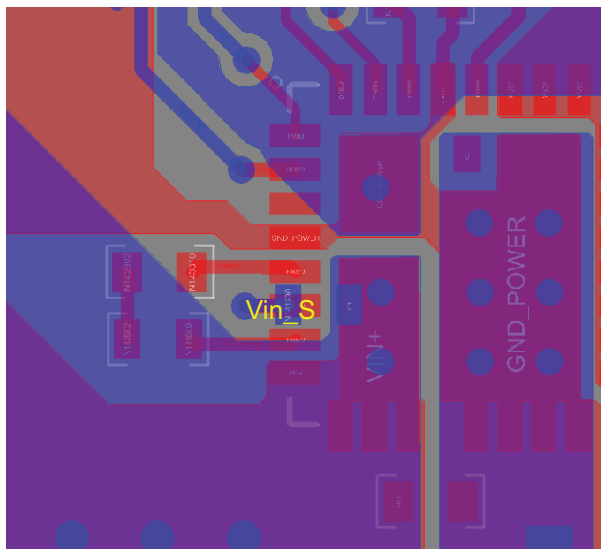
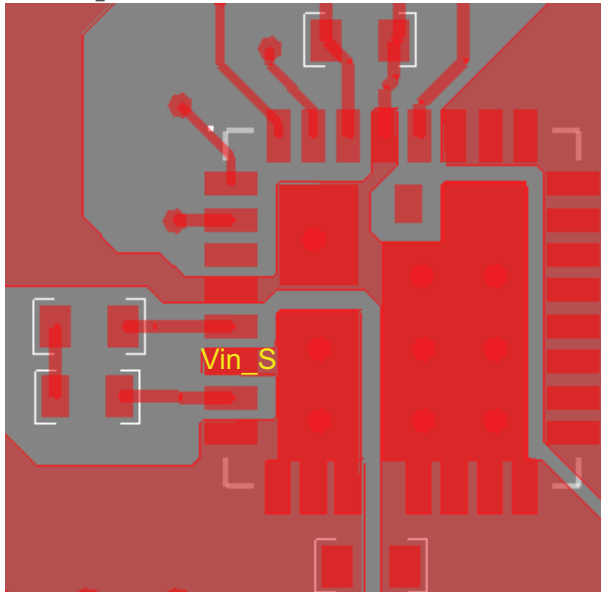
**Step 5:  $V_{IN\_S}$  Connection**

1.  $V_{IN\_S}$  (pin 6) is used to detect HS MOSFET over current. Connect this pin to the  $V_{IN}$  pad
2. To keep the connection flexibility,  $V_{IN\_S}$  (pin 6) can be connected with  $V_{IN}$  through a Via and resistor as shown above. Floating the  $V_{IN\_S}$  pin by unpopulating the resistor will NOT affect normal operation, but this will disable the HS OCP function

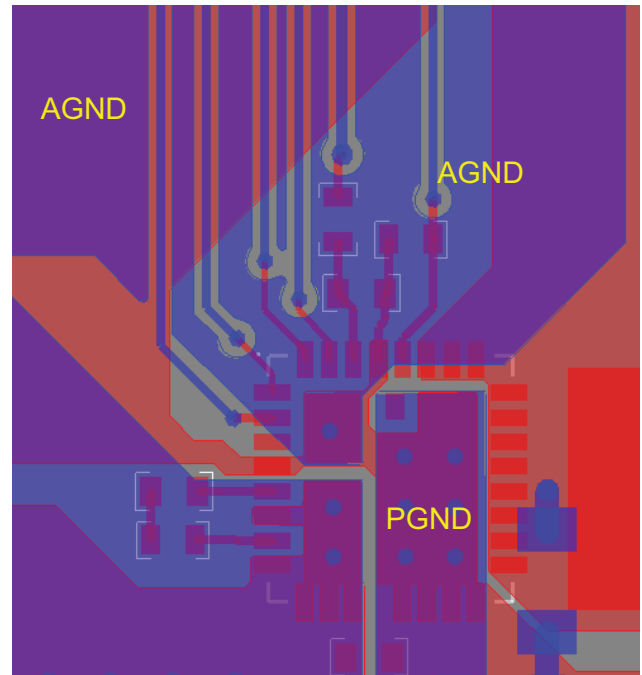
**Step 6: Signal Routing**

1. Route the PWM / SMOD / DSBL / THDN signal traces out of the top left corner next DrMOS pin1
2. It is important to keep the PWM signal quiet by paying special attention to not route it through any noisy source on any layer
3. It is best to “shield” them with GND island from power switching nodes, e.g.  $V_{SWH}$ , to improve signal integrity
4. GL (pin27) has been connected with GL pad internally and does not need to be connected together externally

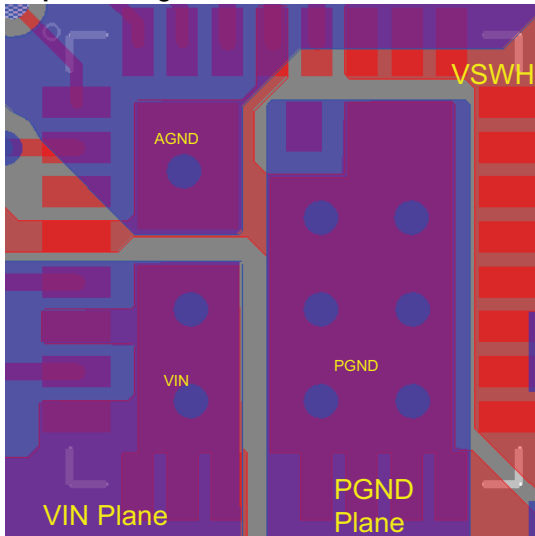
**Step 7: Adding Thermal Relief Vias**

1. Thermal relief Vias can be added on the  $V_{IN}$  and GND pads to utilize inner layers for high current and thermal dissipation
2. To achieve better thermal performance, additional Vias can be put on  $V_{IN}$  plane and  $P_{GND}$  plane
3.  $V_{SWH}$  pad is a noise source and not recommended to put Vias on this plane
4. 8 mil drill for pads and 10 mils drill for plane can be the optional Via size with 40 mils pitch. The Vias on pad may drain solder during assembly and cause assembly issue. Please consult with the assembly house for guideline

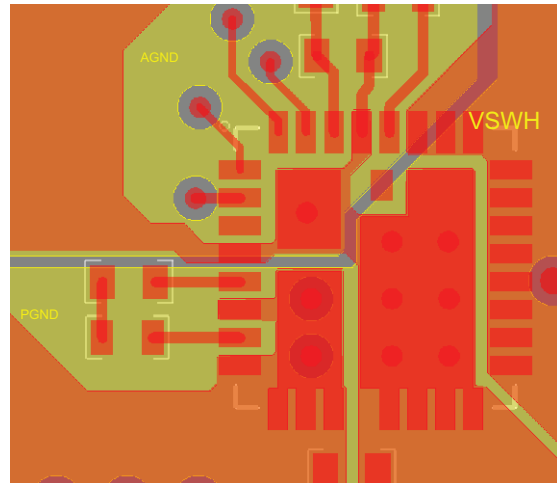
**Step 8: Ground Connection**

5. It is recommended to make single connection between  $A_{GND}$  and  $P_{GND}$  and this connection can be done on top layer
6. It is recommended to make the whole inner 1 layer (next to top layer) ground plane and separate them into  $A_{GND}$  and  $P_{GND}$  plane
7. These ground planes provide shielding between noise source on top layer and signal trace on bottom layer

**Multi-Phases VRPower PCB Layout**

The following is an example of 6 phase layout. As can be seen, all the VRPower stages are lined in X-direction compactly with decoupling capacitors next to them. The inductors are placed as close as possible to the SiCQ670 to minimize the PCB copper loss. Vias are applied on all PADs ( $V_{IN}$ ,  $P_{GND}$ ,  $C_{GND}$ ) of the SiCQ670 to ensure that both electrical and thermal performance are optimized. Large copper planes are used for all high current loops, such as  $V_{IN}$ ,  $V_{SWH}$ ,  $V_{OUT}$  and  $P_{GND}$ . These copper planes are duplicated in other layers to minimize the inductance and resistance. All the control signals are routed from the SiCQ670 to a controller placed to the north of the power stage through inner layers to avoid the overlap of high current loops. This achieves a compact design with the output from the inductors feeding a load located to the south of the design as shown in the figure.

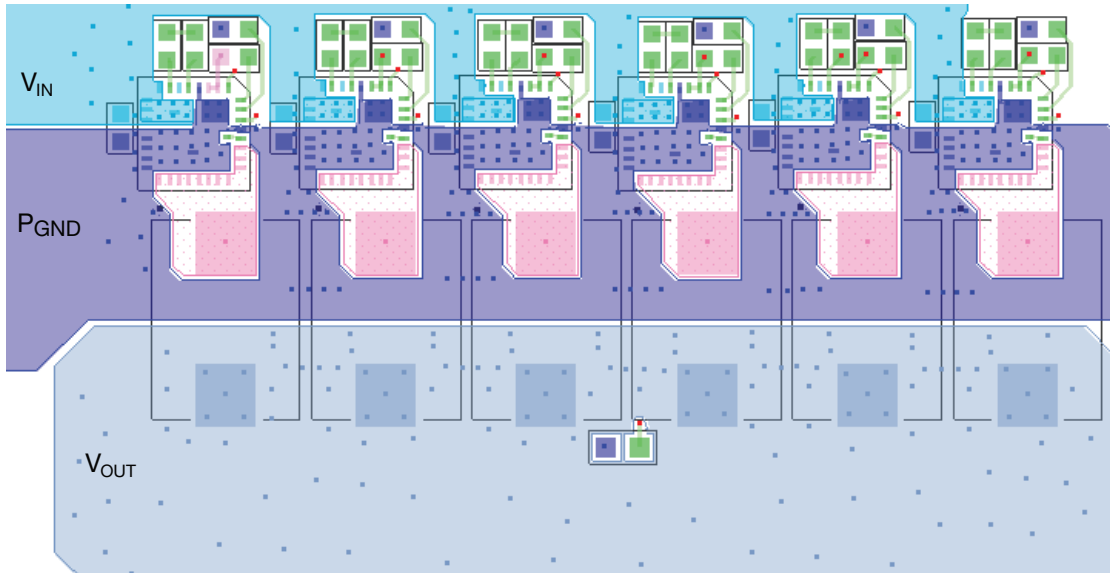
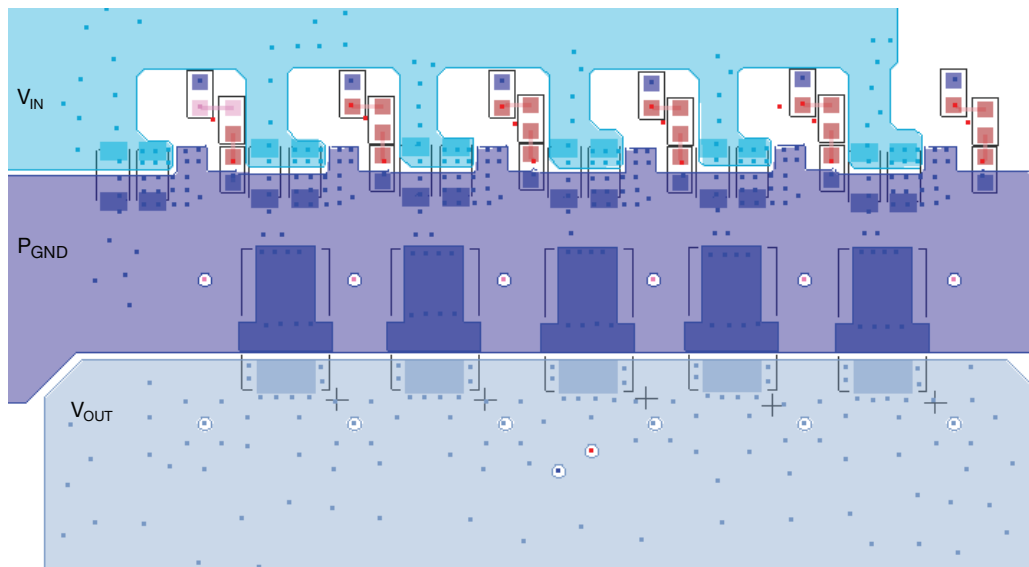
**Fig. 17 - Multi-Phase VRPower Layout Top View**

**Fig. 18 - Multi-Phase VRPower Layout Bottom View**



PRODUCT SUMMARY	
Part number	SiCQ670
Description	50 A Power stage plus, 2.5 V to 24 V <sub>in</sub> , 5 V P <sub>WM</sub> with ZCD mode
Input voltage min. (V)	2.5
Input voltage max. (V)	24
Current rating (A)	50
Switch frequency max. (kHz)	2000
Enable (yes / no)	Yes
Monitoring features	T <sub>MON</sub> /FAULT Monitor
Protection	OCP, OTP, UVLO, HSS
Light load mode	ZCD
Pulse-width modulation (V)	5
Package type	PowerPAK <sup>®</sup> MLP55-31L
Package size (W, L, H) (mm)	5 x 5 x 0.75
Status code	1
Product type	VRPower (DrMOS)
Applications	<ul style="list-style-type: none"> <li>• SoC/FPGA power for autonomous driving or ADAS modules</li> <li>• Artificial intelligence acceleration or machine learning module</li> <li>• Graphic processing unit</li> <li>• Cloud computing</li> </ul>

Vishay Siliconix maintains worldwide manufacturing capability. Products may be manufactured at one of several qualified locations. Reliability data for Silicon Technology and Package Reliability represent a composite of all qualified locations. For related documents such as package / tape drawings, part marking, and reliability data, see [www.vishay.com/ppg?70101](http://www.vishay.com/ppg?70101)



## Disclaimer

ALL PRODUCT, PRODUCT SPECIFICATIONS AND DATA ARE SUBJECT TO CHANGE WITHOUT NOTICE TO IMPROVE RELIABILITY, FUNCTION OR DESIGN OR OTHERWISE.

Vishay Intertechnology, Inc., its affiliates, agents, and employees, and all persons acting on its or their behalf (collectively, "Vishay"), disclaim any and all liability for any errors, inaccuracies or incompleteness contained in any datasheet or in any other disclosure relating to any product.

Vishay makes no warranty, representation or guarantee regarding the suitability of the products for any particular purpose or the continuing production of any product. To the maximum extent permitted by applicable law, Vishay disclaims (i) any and all liability arising out of the application or use of any product, (ii) any and all liability, including without limitation special, consequential or incidental damages, and (iii) any and all implied warranties, including warranties of fitness for particular purpose, non-infringement and merchantability.

Statements regarding the suitability of products for certain types of applications are based on Vishay's knowledge of typical requirements that are often placed on Vishay products in generic applications. Such statements are not binding statements about the suitability of products for a particular application. It is the customer's responsibility to validate that a particular product with the properties described in the product specification is suitable for use in a particular application. Parameters provided in datasheets and / or specifications may vary in different applications and performance may vary over time. All operating parameters, including typical parameters, must be validated for each customer application by the customer's technical experts. Product specifications do not expand or otherwise modify Vishay's terms and conditions of purchase, including but not limited to the warranty expressed therein.

Hyperlinks included in this datasheet may direct users to third-party websites. These links are provided as a convenience and for informational purposes only. Inclusion of these hyperlinks does not constitute an endorsement or an approval by Vishay of any of the products, services or opinions of the corporation, organization or individual associated with the third-party website. Vishay disclaims any and all liability and bears no responsibility for the accuracy, legality or content of the third-party website or for that of subsequent links.

Vishay products are not designed for use in life-saving or life-sustaining applications or any application in which the failure of the Vishay product could result in personal injury or death unless specifically qualified in writing by Vishay. Customers using or selling Vishay products not expressly indicated for use in such applications do so at their own risk. Please contact authorized Vishay personnel to obtain written terms and conditions regarding products designed for such applications.

No license, express or implied, by estoppel or otherwise, to any intellectual property rights is granted by this document or by any conduct of Vishay. Product names and markings noted herein may be trademarks of their respective owners.