

Power-off Protection, 6 Ω, 1.8 V to 5.5 V, SPDT Analog Switch (2:1 Multiplexer)

DESCRIPTION

The DG2002E is a high performance single-pole, double-throw (SPDT) analog switch designed for 1.8 V to 5.5 V operation with a single power rail.

Fabricated with high density CMOS technology, the device achieves low on resistance of 6 Ω and switch off capacitance of 7 pF at a 5 V power supply and low power consumption, and fast switching speeds. Its charge injection is 1 pC.

The DG2002E can handle both analog and digital signals and permits signals with amplitudes of up to V+ to be transmitted in either direction. Its control logic inputs can go over V+ up to 5.5 V. It features break before make switching performance.

A powered-off protection circuit is built into the switch to prevent an abnormal current flow from COM pin to V+ during the power-down condition. Each output pin can withstand greater than 7 kV (human body model).

Operation temperature is specified from -40 °C to +85 °C. The DG2002E is available in the compact SC-70-6L package.

FEATURES

- Low switch on-resistance (6 Ω)
- +1.8 V to +5.5 V single supply operation
- Powered-off protection
- Control logic inputs can go over V+
- Low parasitic capacitance, 7 pF at switch off
- Low charge injection, 1 pC
- Break before make switching
- Latch-up performance exceeds 200 mA per JESD 78
 - 7000 V human body model (JS-001)
 - 1000 V charge device model (JS-002)
- High ESD rating
- Material categorization: for definitions of compliance please see www.vishay.com/doc?99912



Note

* This datasheet provides information about parts that are RoHS-compliant and / or parts that are non RoHS-compliant. For example, parts with lead (Pb) terminations are not RoHS-compliant. Please see the information / tables in this datasheet for details

APPLICATIONS

- Battery powered devices
- Instrumentation
- Medical equipment
- Low voltage data acquisition
- Control and automation
- Consumer and computing

FUNCTIONAL BLOCK DIAGRAM AND PIN CONFIGURATION

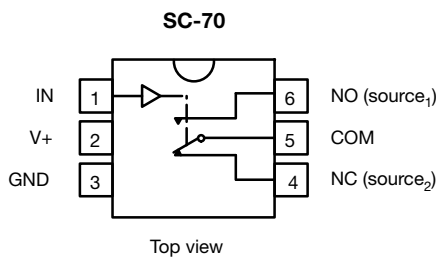

Device marking: H9

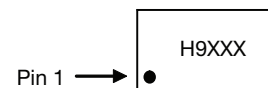

Device marking: H9XXX
XXX = Date / lot traceability code

TRUTH TABLE		
LOGIC	NC	NO
0	On	Off
1	Of	On

Notes

- Logic "0" ≤ 0.8 V
- Logic "1" ≥ 2.4 V

ORDERING INFORMATION		
TEMP. RANGE	PACKAGE	PART NUMBER
-40 °C to +85 °C	SC-70-6	DG2002EDL-T1-GE3



ABSOLUTE MAXIMUM RATINGS			
PARAMETER		LIMIT	UNIT
V+, COM, NC, NO, IN reference to GND		-0.3 to 6	V
Continuous current (any terminal)		± 50	mA
Peak current (pulsed at 1 ms, 10 % duty cycle)		± 200	
Storage temperature		-65 to +150	°C
Power dissipation (packages) ^a	6-pin SC-70 ^b	250	mW
ESD / HBM	JS-001	7000	V
ESD / CDM	JS-002	1000	
Latch up	Per JEDEC78 with 1.5 x voltage clamp	200	mA

Notes

- a. All leads welded or soldered to PC board
- b. Derate 3.1 mW/°C above 70 °C

Stresses beyond those listed under "Absolute Maximum Ratings" may cause permanent damage to the device. These are stress ratings only, and functional operation of the device at these or any other conditions beyond those indicated in the operational sections of the specifications is not implied. Exposure to absolute maximum rating conditions for extended periods may affect device reliability.

SPECIFICATIONS (V+ = 5 V)								
PARAMETER	SYMBOL	TEST CONDITIONS UNLESS OTHERWISE SPECIFIED V+ = 5 V, ± 10 % VIN = 0.8 V or 2.4 V ^e	TEMP. ^a	LIMITS -40 °C to +85 °C			UNIT	
				MIN. ^b	TYP. ^c	MAX. ^b		
Analog Switch								
Analog signal range ^d	V _{NO} , V _{NC} V _{COM}		Full	0	-	V+	V	
Drain-source on-resistance ^d	R _{DS(on)}	V+ = 4.5 V, V _{COM} = 3 V, I _{NO} , I _{NC} = 10 mA	Room Full	- -	6 8	8 10	Ω	
R _{DS(on)} flatness ^d	R _{DS(on)} flatness	V+ = 5 V, V _{COM} = 1.5 V, 3.5 V, I _{NO} , I _{NC} = 10 mA	Room	-	0.4	-		
R _{DS(on)} match ^d	ΔR _{DS(on)}	V+ = 4.5 V, V _{COM} = 3 V, I _{NO} , I _{NC} = 10 mA	Room	-	0.04	0.2		
Switch-off leakage current ^f	I _{NO(off)} , I _{NC(off)}	V+ = 5.5 V, V _{NO} , V _{NC} = 1 V / 4.5 V, V _{COM} = 4.5 V / 1 V	Room Full	-1.5 -4	- -	1.5 4	nA	
	I _{COM(off)}		Room Full	-1 -4	- -	1 4		
Channel-on leakage current ^f	I _{COM(on)}	V+ = 5.5 V, V _{NO} , V _{NC} = V _{COM} = 1 V / 4.5 V	Room Full	-1 -4	- -	1 4		
			Power-down leakage	I _{PD}	V+ = 0 V, V _{COM} = 5 V, NO/NC open, V _{IN} = GND V+ = 0 V, V _{NO} , V _{NC} = 5 V, COM open, V _{IN} = GND	Full Full		- -
Digital Control								
Input high voltage	V _{INH}		Full	2.4	-	-	V	
Input low voltage	V _{INL}		Full	-	-	0.8		
Input capacitance ^d	C _{IN}		Full	-	6	-	pF	
Input current	I _{INL} or I _{INH}	V _{IN} = 0 V or V+	Full	-1	-	1	μA	
Dynamic Characteristics								
Turn-on time ^d	t _{ON}	V _{NO} or V _{NC} = 3 V, R _L = 300 Ω, C _L = 35 pF	Room Full	- -	10 -	30 32	ns	
			Turn-off time ^d	t _{OFF}	Room Full	- -		8 -
Break-before-make time ^d	t _{BBM}				Room	1		-
Charge injection ^d	Q _{INJ}		C _L = 1 nF, V _{GEN} = 0 V, V _{NO} , V _{NC} = 0 V, R _{GEN} = 0 Ω	Room	-	1		-
Off-isolation ^d	OIRR		R _L = 50 Ω, C _L = 5 pF, f = 1 MHz	Room	-	-78	-	dB
Crosstalk ^d	X _{TALK}			Room	-	-77	-	
NO, NC off capacitance ^d	C _{NO(off)}	V _{IN} = 0 V or V+, f = 1 MHz	Room	-	7	-	pF	
	C _{NC(off)}		Room	-	7	-		
Channel-on capacitance ^d	C _{ON}		Room	-	13	-		
			Room	-	13	-		
Power Supply								
Power supply current ^d	I+	V _{IN} = 0 V or V+	Full	-	0.004	1	μA	



SPECIFICATIONS (V+ = 3 V)								
PARAMETER	SYMBOL	TEST CONDITIONS UNLESS OTHERWISE SPECIFIED V+ = 3 V, ± 10 % VIN = 0.4 V or 2 V ^e	TEMP. ^a	LIMITS -40 °C to +85 °C			UNIT	
				MIN. ^b	TYP. ^c	MAX. ^b		
Analog Switch								
Analog signal range ^d	V _{NO} , V _{NC} V _{COM}		Full	0	-	V+	V	
Drain-source on-resistance ^d	R _{DS(on)}	V+ = 2.7 V, V _{COM} = 1.5 V, I _{NO} , I _{NC} = 10 mA	Room	-	13	22	Ω	
			Full	-	15	24		
R _{DS(on)} flatness ^d	R _{DS(on)} flatness	V+ = 3 V, V _{COM} = 0 V to V+, I _{NO} , I _{NC} = 10 mA	Room	-	1.4	-	Ω	
R _{DS(on)} match ^d	ΔR _{DS(on)}	V+ = 2.7 V, V _{COM} = 1.5 V, I _{NO} , I _{NC} = 10 mA	Room	-	0.03	0.35		
Switch-off leakage current ^f	I _{NO(off)} , I _{NC(off)}	V+ = 3.3 V, V _{NO} , V _{NC} = 1 V / 3 V, V _{COM} = 3 V / 1 V	Room	-0.4	-	0.4	nA	
			Full	-4	-	4		
	Room		-0.8	-	0.8			
	Full		-8	-	8			
Channel-on leakage current ^f	I _{COM(on)}	V+ = 3.3 V, V _{NO} , V _{NC} = V _{COM} = 1 V / 3 V	Room	-0.8	-	0.8	nA	
			Full	-8	-	8		
Digital Control								
Input high voltage	V _{INH}		Full	2	-	-	V	
Input low voltage	V _{INL}		Full	-	-	0.4		
Input capacitance ^d	C _{IN}		Full	-	6	-	pF	
Input current	I _{INL} or I _{INH}	V _{IN} = 0 V or V+	Full	-1	-	1	μA	
Dynamic Characteristics								
Turn-on time ^d	t _{ON}	V _{NO} or V _{NC} = 2 V, R _L = 300 Ω, C _L = 35 pF	Room	-	13	34	ns	
			Full	-	-	37		
Turn-off time ^d	t _{OFF}		Room	-	9	20		
			Full	-	-	22		
Break-before-make time ^d	t _{BBM}			Room	1	-		-
Charge injection ^d	Q _{INJ}		C _L = 1 nF, V _{GEN} = 0 V, V _{NO} , V _{NC} = 0 V, R _{GEN} = 0 Ω	Room	-	0.9		-
Off-isolation ^d	OIRR	R _L = 50 Ω, C _L = 5 pF, f = 1 MHz	Room	-	-78	-	dB	
Crosstalk ^d	X _{TALK}		Room	-	-77	-		
NO, NC off capacitance ^d	C _{NO(off)}	V _{IN} = 0 V or V+, f = 1 MHz	Room	-	7	-	pF	
	C _{NC(off)}		Room	-	7	-		
Channel-on capacitance ^d	C _{ON}		Room	-	14	-		
Power Supply								
Power supply current ^d	I+	V _{IN} = 0 V or V+	Full	-	0.002	1	μA	



SPECIFICATIONS (V+ = 2.5 V)								
PARAMETER	SYMBOL	TEST CONDITIONS UNLESS OTHERWISE SPECIFIED V+ = 2.5 V, ± 10 % VIN = 0.4 V or 2 V ^e	TEMP. ^a	LIMITS -40 °C to +85 °C			UNIT	
				MIN. ^b	TYP. ^c	MAX. ^b		
Analog Switch								
Analog signal range ^d	V _{NO} , V _{NC} V _{COM}		Full	0	-	V+	V	
Drain-source on-resistance ^d	R _{DS(on)}	V+ = 2.2 V, V _{COM} = 1 V, I _{NO} , I _{NC} = 10 mA	Room Full ^d	- -	23 24	27 28	Ω	
R _{DS(on)} flatness ^d	R _{DS(on)} flatness	V+ = 2.5 V, V _{COM} = 0 V to V+, I _{NO} , I _{NC} = 10 mA	Room	-	1.7	-		
R _{DS(on)} match ^d	ΔR _{DS(on)}	V+ = 2.2 V, V _{COM} = 1.2 V, I _{NO} , I _{NC} = 10 mA	Room	-	0.1	0.5		
Switch-off leakage current ^f	I _{NO(off)} , I _{NC(off)}	V+ = 2.7 V, V _{NO} , V _{NC} = 0.5 V / 1.5 V, V _{COM} = 1.5 V / 0.5 V	Room	-0.2	-	0.2	nA	
			Full ^d	-3	-	3		
	Room		-0.2	-	0.2			
	Full ^d		-3	-	3			
Channel-on leakage current ^f	I _{COM(on)}	V+ = 2.7 V, V _{NO} , V _{NC} = V _{COM} = 0.5 V / 1.5 V	Room Full ^d	-0.2 -3	- -	0.2 3	nA	
Digital Control								
Input high voltage	V _{INH}		Full	2	-	-	V	
Input low voltage	V _{INL}		Full	-	-	0.4		
Input capacitance ^d	C _{IN}		Full	-	6	-	pF	
Input current	I _{INL} or I _{INH}	V _{IN} = 0 V or V+	Full	-1	-	1	μA	
Dynamic Characteristics								
Turn-on time ^d	t _{ON}	V _{NO} or V _{NC} = 1.5 V, R _L = 300 Ω, C _L = 35 pF	Room	-	16	36	ns	
			Full ^d	-	-	38		
Turn-off time ^d	t _{OFF}		Room	-	10	19		
			Full	-	-	21		
Break-before-make time ^d	t _{BBM}			Room ^d	1	-		-
Charge injection ^d	Q _{INJ}		C _L = 1 nF, V _{GEN} = 0 V, V _{NO} , V _{NC} = 0 V, R _{GEN} = 0 Ω	Room	-	0.9		-
Off-isolation ^d	OIRR	R _L = 50 Ω, C _L = 5 pF, f = 1 MHz	Room	-	-78	-	dB	
Crosstalk ^d	X _{TALK}		Room	-	-77	-		
NO, NC off capacitance ^d	C _{NO(off)}	V _{IN} = 0 V or V+, f = 1 MHz	Room	-	7	-	pF	
	C _{NC(off)}		Room	-	7	-		
Channel-on capacitance ^d	C _{ON}		Room	-	14	-		
Power Supply								
Power supply current ^d	I+	V _{IN} = 0 V or V+	Full	-	-	1	μA	



SPECIFICATIONS (V+ = 2 V)								
PARAMETER	SYMBOL	TEST CONDITIONS UNLESS OTHERWISE SPECIFIED V+ = 2 V, ± 10 % VIN = 0.4 V or 1.6 V ^e	TEMP. ^a	LIMITS -40 °C to +85 °C			UNIT	
				MIN. ^b	TYP. ^c	MAX. ^b		
Analog Switch								
Analog signal range ^d	V _{NO} , V _{NC} V _{COM}		Full	0	-	V+	V	
Drain-source on-resistance ^d	R _{DS(on)}	V+ = 1.8 V, V _{COM} = 1 V, I _{NO} , I _{NC} = 10 mA	Room Full ^d	- -	37 36	42 44	Ω	
R _{DS(on)} flatness ^d	R _{DS(on)} flatness	V+ = 2 V, V _{COM} = 0 V to V+, I _{NO} , I _{NC} = 10 mA	Room	-	3	-		
R _{DS(on)} match ^d	ΔR _{DS(on)}	V+ = 1.8 V, V _{COM} = 1 V, I _{NO} , I _{NC} = 10 mA	Room	-	0.04	0.5		
Switch-off leakage current ^f	I _{NO(off)} , I _{NC(off)}	V+ = 2.2 V, V _{NO} , V _{NC} = 0.5 V / 1.5 V, V _{COM} = 1.5 V / 0.5 V	Room	-0.2	-	0.2	nA	
			Full ^d	-3	-	3		
	Room		-0.2	-	0.2			
	Full ^d		-3	-	3			
Channel-on leakage current ^f	I _{COM(on)}	V+ = 2.2 V, V _{NO} , V _{NC} = V _{COM} = 0.5 V / 1.5 V	Room	-0.2	-	0.2	nA	
			Full ^d	-3	-	3		
Digital Control								
Input high voltage	V _{INH}		Full	1.6	-	-	V	
Input low voltage	V _{INL}		Full	-	-	0.4		
Input capacitance ^d	C _{IN}		Full	-	6	-	pF	
Input current	I _{INL} or I _{INH}	V _{IN} = 0 V or V+	Full	-1	-	1	μA	
Dynamic Characteristics								
Turn-on time ^d	t _{ON}	V _{NO} or V _{NC} = 1.5 V, R _L = 300 Ω, C _L = 35 pF	Room	-	21	40	ns	
			Full ^d	-	-	42		
Turn-off time ^d	t _{OFF}		Room	-	13	20		
			Full ^d	-	-	21		
Break-before-make time ^d	t _{BBM}			Room	1	-		-
Charge injection ^d	Q _{INJ}		C _L = 1 nF, V _{GEN} = 0 V, V _{NO} , V _{NC} = 0 V, R _{GEN} = 0 Ω	Room	-	0.8		-
Off-isolation ^d	OIRR	R _L = 50 Ω, C _L = 5 pF, f = 1 MHz	Room	-	-78	-	dB	
Crosstalk ^d	X _{TALK}		Room	-	-77	-		
NO, NC off capacitance ^d	C _{NO(off)}	V _{IN} = 0 V or V+, f = 1 MHz	Room	-	7	-	pF	
	C _{NC(off)}		Room	-	7	-		
Channel-on capacitance ^d	C _{ON}		Room	-	14	-		
Power Supply								
Power supply current ^d	I+	V _{IN} = 0 V or V+	Full	-	-	1	μA	

Notes

- a. Room = 25 °C, full = as determined by the operating suffix
- b. The algebraic convention whereby the most negative value is a minimum and the most positive a maximum, is used in this datasheet
- c. Typical values are for design aid only, not guaranteed nor subject to production testing
- d. Guarantee by design, nor subjected to production test
- e. V_{IN} = input voltage to perform proper function
- f. Guaranteed by 5 V leakage testing, not production tested

TYPICAL CHARACTERISTICS (25 °C, unless otherwise noted)

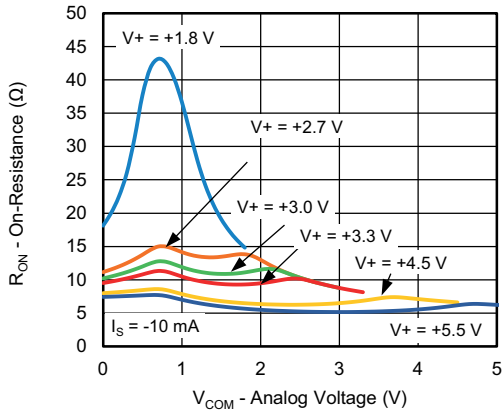

$R_{DS(on)}$ vs. V_{COM} and Supply Voltage

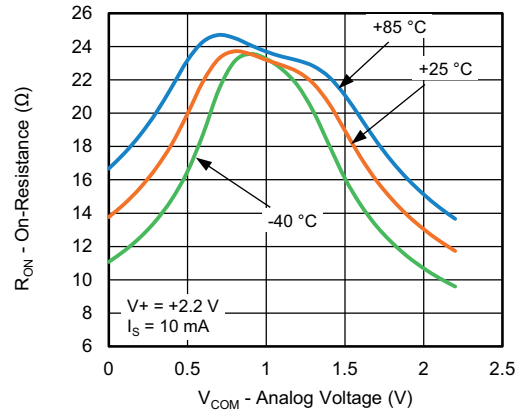

$R_{DS(on)}$ vs. Analog Voltage and Temperature

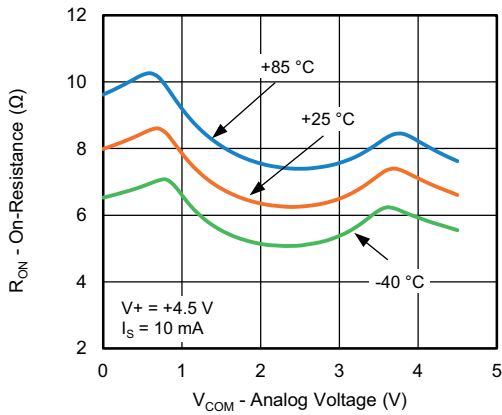

$R_{DS(on)}$ vs. Analog Voltage and Temperature

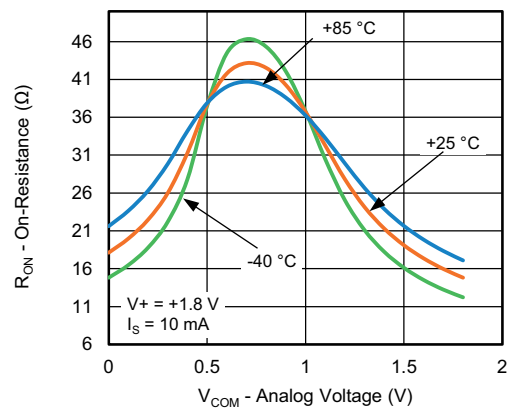

$R_{DS(on)}$ vs. Analog Voltage and Temperature

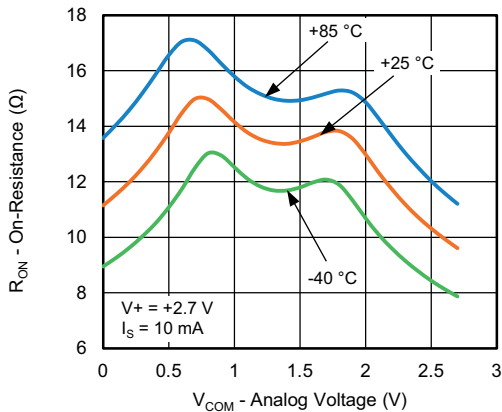

$R_{DS(on)}$ vs. Analog Voltage and Temperature

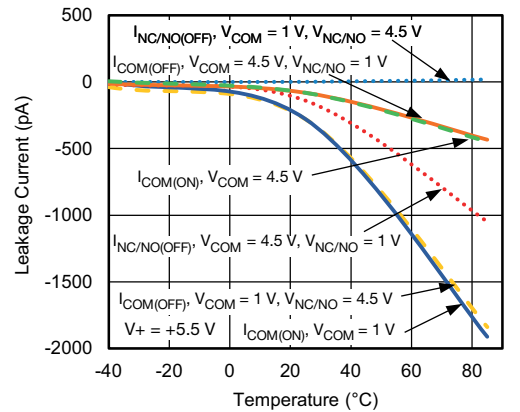

Leakage Current vs. Temperature



TYPICAL CHARACTERISTICS (25 °C, unless otherwise noted)

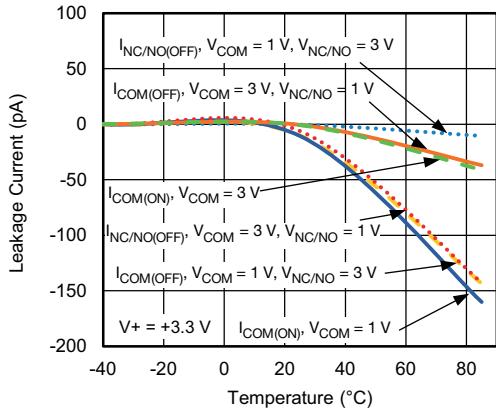

Leakage Current vs. Temperature

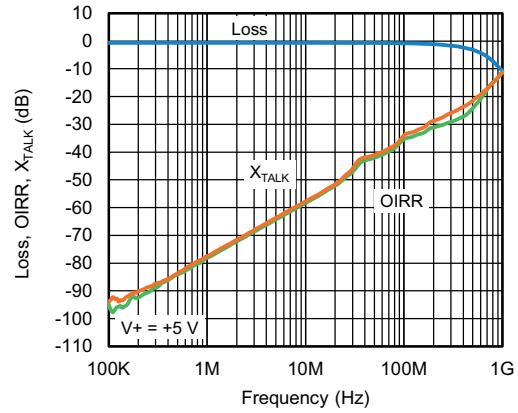

Insertion Loss, Off-Isolation Crosstalk vs. Frequency

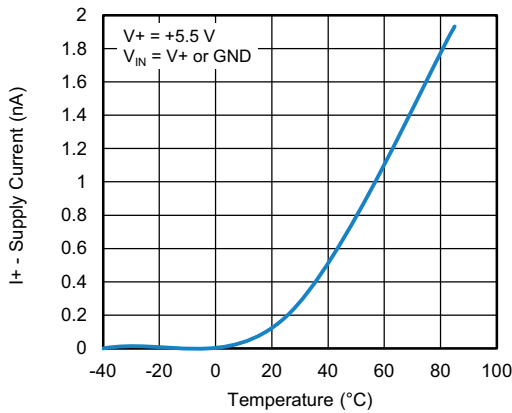

Supply Current vs. Temperature

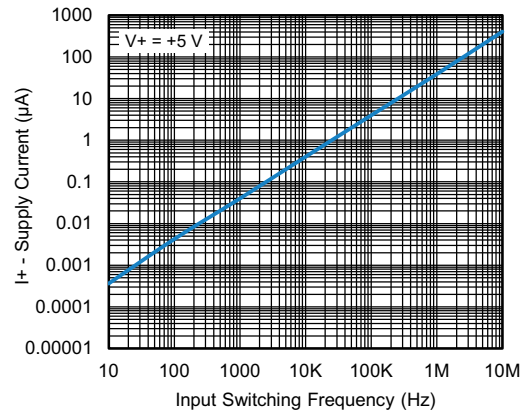

Supply Current vs. Input Switching Frequency

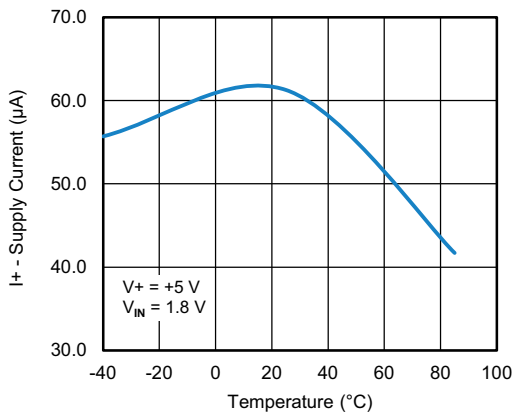

Supply Current vs. Temperature

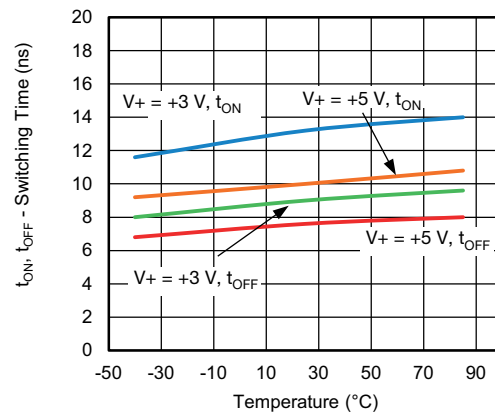

Switching Time vs. Temperature

TYPICAL CHARACTERISTICS (25 °C, unless otherwise noted)

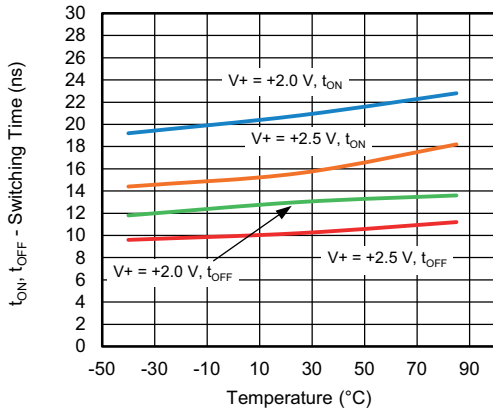

Switching Time vs. Temperature

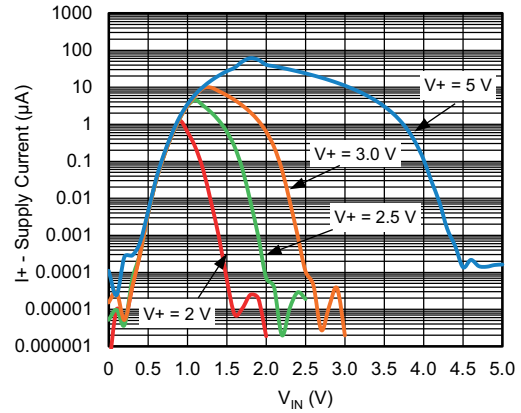

Supply Current vs. Enable Input Voltage

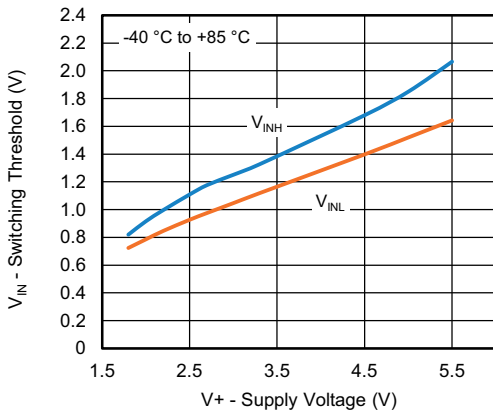

Switching Threshold vs. Supply Voltage

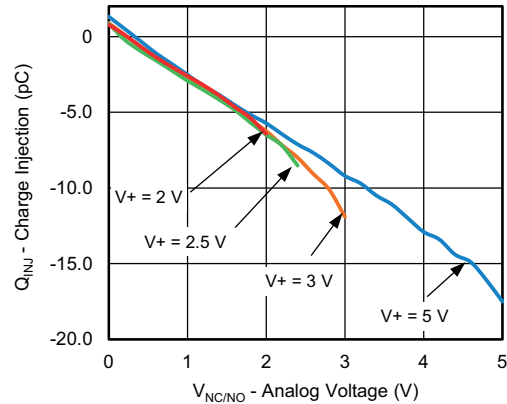

Charge Injection vs. Analog Voltage

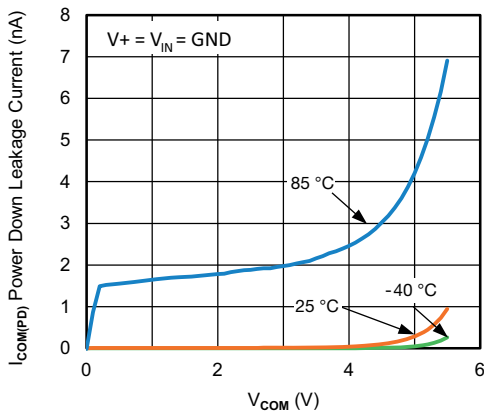

Power Down Leakage Current vs V_{COM}

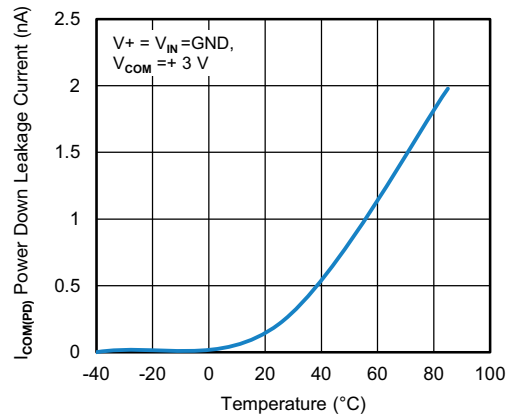

Power Down Leakage Current vs Temperature

TEST CIRCUITS

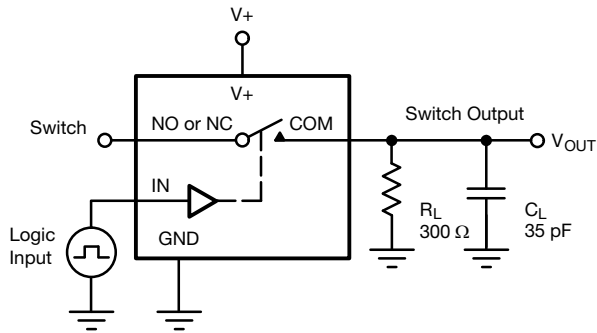

C_L (includes fixture and stray capacitance)

$$V_{OUT} = V_{COM} \left(\frac{R_L}{R_L + R_{ON}} \right)$$

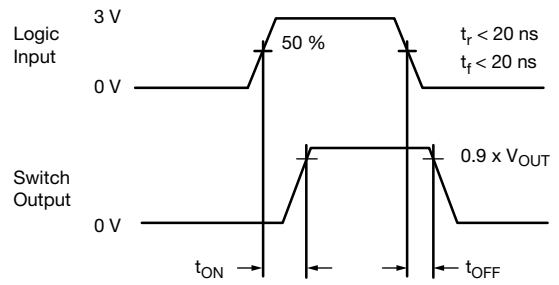

Logic "1" = switch on
Logic input waveforms inverted for switches that have the opposite logic sense.

Fig. 1 - Switching Time

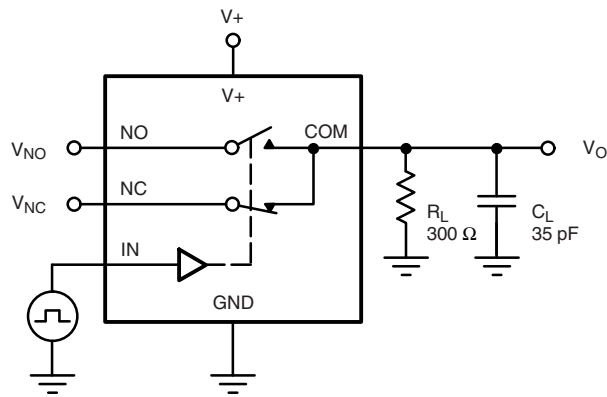

C_L (includes fixture and stray capacitance)

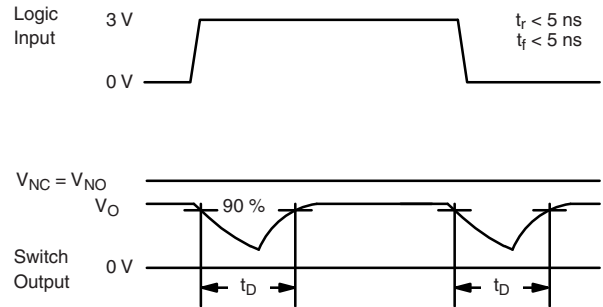
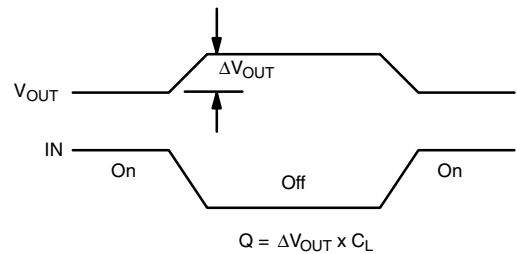
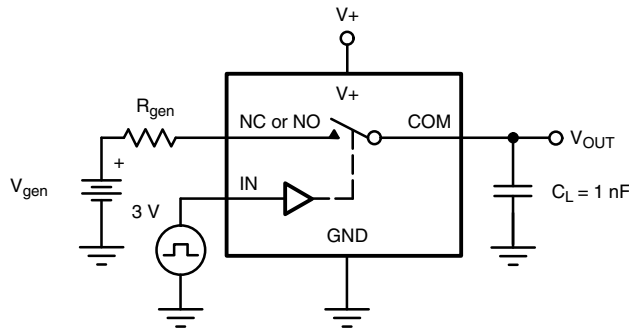
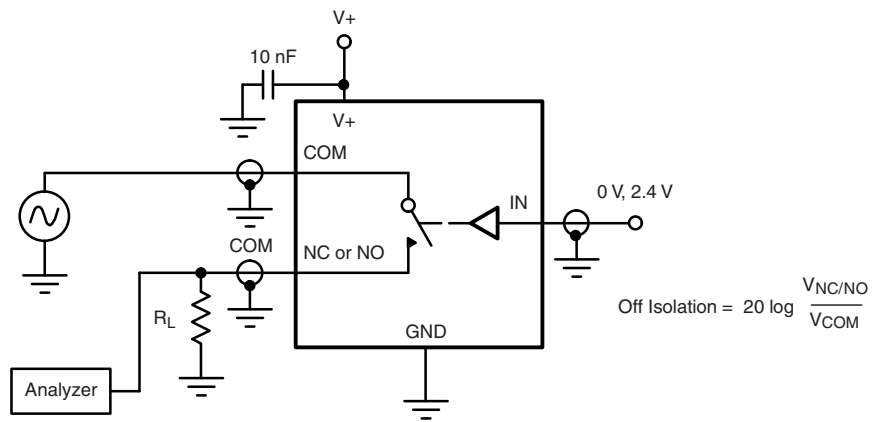
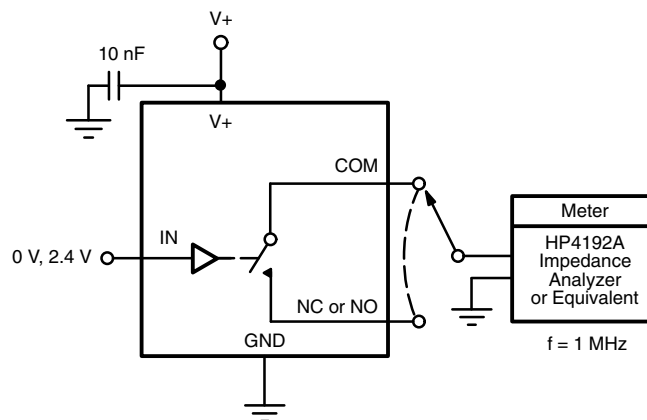

Fig. 2 - Break-Before-Make Interval



IN depends on switch configuration: input polarity determined by sense of switch.

Fig. 3 - Charge Injection

TEST CIRCUITS

Fig. 4 - Off-Isolation

Fig. 5 - Channel Off / On Capacitance

Vishay Siliconix maintains worldwide manufacturing capability. Products may be manufactured at one of several qualified locations. Reliability data for Silicon Technology and Package Reliability represent a composite of all qualified locations. For related documents such as package / tape drawings, part marking, and reliability data, see www.vishay.com/ppg?76624.



Disclaimer

ALL PRODUCT, PRODUCT SPECIFICATIONS AND DATA ARE SUBJECT TO CHANGE WITHOUT NOTICE TO IMPROVE RELIABILITY, FUNCTION OR DESIGN OR OTHERWISE.

Vishay Intertechnology, Inc., its affiliates, agents, and employees, and all persons acting on its or their behalf (collectively, "Vishay"), disclaim any and all liability for any errors, inaccuracies or incompleteness contained in any datasheet or in any other disclosure relating to any product.

Vishay makes no warranty, representation or guarantee regarding the suitability of the products for any particular purpose or the continuing production of any product. To the maximum extent permitted by applicable law, Vishay disclaims (i) any and all liability arising out of the application or use of any product, (ii) any and all liability, including without limitation special, consequential or incidental damages, and (iii) any and all implied warranties, including warranties of fitness for particular purpose, non-infringement and merchantability.

Statements regarding the suitability of products for certain types of applications are based on Vishay's knowledge of typical requirements that are often placed on Vishay products in generic applications. Such statements are not binding statements about the suitability of products for a particular application. It is the customer's responsibility to validate that a particular product with the properties described in the product specification is suitable for use in a particular application. Parameters provided in datasheets and / or specifications may vary in different applications and performance may vary over time. All operating parameters, including typical parameters, must be validated for each customer application by the customer's technical experts. Product specifications do not expand or otherwise modify Vishay's terms and conditions of purchase, including but not limited to the warranty expressed therein.

Hyperlinks included in this datasheet may direct users to third-party websites. These links are provided as a convenience and for informational purposes only. Inclusion of these hyperlinks does not constitute an endorsement or an approval by Vishay of any of the products, services or opinions of the corporation, organization or individual associated with the third-party website. Vishay disclaims any and all liability and bears no responsibility for the accuracy, legality or content of the third-party website or for that of subsequent links.

Except as expressly indicated in writing, Vishay products are not designed for use in medical, life-saving, or life-sustaining applications or for any other application in which the failure of the Vishay product could result in personal injury or death. Customers using or selling Vishay products not expressly indicated for use in such applications do so at their own risk. Please contact authorized Vishay personnel to obtain written terms and conditions regarding products designed for such applications.

No license, express or implied, by estoppel or otherwise, to any intellectual property rights is granted by this document or by any conduct of Vishay. Product names and markings noted herein may be trademarks of their respective owners.