

# 55 A VRPower® Integrated Power Stage

(Datasheet in Brief)

## DESCRIPTION

The SiC641 and SiC641A are high frequency integrated power stage optimized for synchronous buck applications to offer high current, high efficiency, and high power density performance with very low shutdown current. Packaged in Vishay's proprietary 5 mm x 5 mm MLP package, SiC641 and SiC641A enable voltage regulator designs to deliver up to 55 A continuous current per phase.

The internal power MOSFETs utilize Vishay's latest TrenchFET® technology that delivers industry benchmark performance to significantly reduce switching and conduction losses.

The SiC641 and SiC641A incorporate an advanced MOSFET gate driver IC that features high current driving capability, adaptive dead-time control, an integrated bootstrap switch, and user selectable zero current detection to improve light load efficiency. The driver is also compatible with a wide range of PWM controllers, supports tri-state PWM, and 5 V and 3.3 V PWM logic.

The device also supports PS4 mode to reduce power consumption when the system is in standby state.

The SiC641 and SiC641A offer operating temperature monitoring, protection features, and warning flags that improve system monitoring and reliability.

## APPLICATIONS

- Multi-phase VRDs for computing, graphics card and memory
- Intel core processor power delivery
  - V<sub>CORE</sub>, V<sub>GRAPHICS</sub>, V<sub>SYSTEM AGENT</sub>
  - V<sub>CCGI</sub>
- Up to 16 V rail input DC/DC VR modules

## TYPICAL APPLICATION DIAGRAM

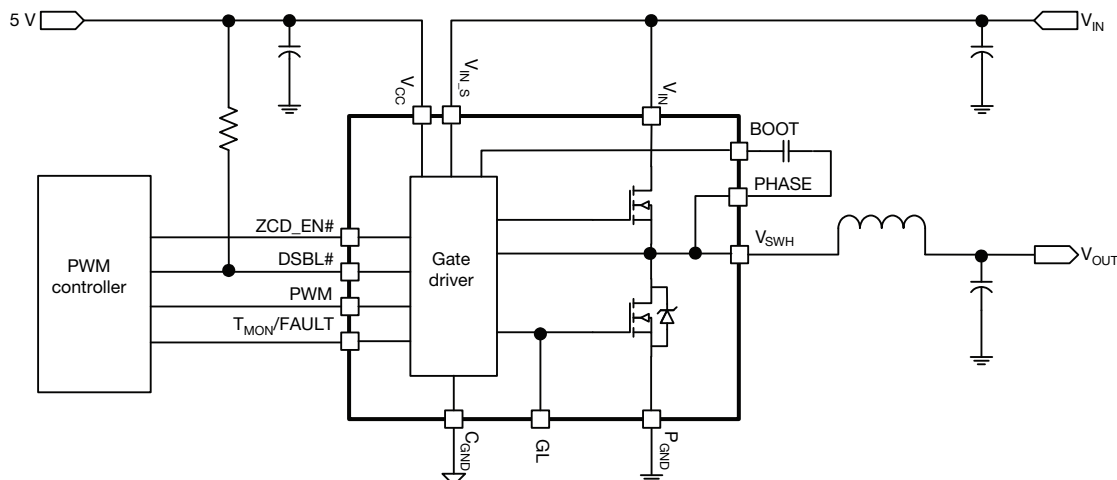

Fig. 1 - Typical Application Diagram

## FEATURES

- Highly efficient
  - Thermally enhanced PowerPAK® MLP55-31L package
  - Vishay's latest TrenchFET technology and low side MOSFET with integrated Schottky diode
  - Integrated, low impedance, bootstrap switch
  - Power MOSFETs optimized for 12 V input stage
  - Supports PS4 mode light load requirement with low shutdown supply current (5 V, 3 μA)
  - Zero current detection for improved light load efficiency
- Highly versatile
  - 5 V and 3.3 V PWM logic with tri-state and hold-off timer
  - 5 V DSBL#, ZCD\_EN# logic with PS4 state support
  - High frequency operation up to 2 MHz
- Robust and reliable
  - Delivers in excess of 55 A continuous current, 70 A, peak (10 ms) and 100 A, peak (10 μs)
  - Over current protection
  - Over temperature flag
  - Over temperature protection
  - Undervoltage lockout protection
  - High side MOSFET short detection
- Effective monitoring and reporting
  - Accurate temperature reporting
  - Warnings and faults reporting flag
- Material categorization: for definitions of compliance please see [www.vishay.com/doc?99912](http://www.vishay.com/doc?99912)



**RoHS**  
COMPLIANT  
HALOGEN  
FREE



PRODUCT SUMMARY		
Part number	SiC641	SiC641A
Description	55 A power stage plus, 2.5 V <sub>IN</sub> to 16 V <sub>IN</sub> , 5 V PWM with ZCD, PS4 mode	55 A power stage plus, 2.5 V <sub>IN</sub> to 16 V <sub>IN</sub> , 3.3 V PWM with ZCD, PS4 mode
Input voltage min. (V)	2.5	2.5
Input voltage max. (V)	16	16
Continuous current rating max. (A)	55	55
Switch frequency max. (kHz)	2000	2000
Enable (yes / no)	Yes	Yes
Monitoring features	T <sub>MON</sub>	T <sub>MON</sub>
Protection	UVLO, OCP, OTP, HS-short	UVLO, OCP, OTP, HS-short
Light load mode	ZCD, PS4	ZCD, PS4
Pulse-width modulation (V)	5	3.3
Package type	PowerPAK MLP55-31L	PowerPAK MLP55-31L
Package size (W, L, H) (mm)	5.0 x 5.0 x 0.75	5.0 x 5.0 x 0.75
Status code	1	1
Product type	VRPower (DrMOS)	VRPower (DrMOS)
Applications	Computers	Computers

To request the full version of the datasheet, please contact: [ICmarketing@vishay.com](mailto:ICmarketing@vishay.com)

Vishay Siliconix maintains worldwide manufacturing capability. Products may be manufactured at one of several qualified locations. Reliability data for Silicon Technology and Package Reliability represent a composite of all qualified locations. For related documents such as package / tape drawings, part marking, and reliability data, see [www.vishay.com/ppg?77474](http://www.vishay.com/ppg?77474).



## Disclaimer

ALL PRODUCT, PRODUCT SPECIFICATIONS AND DATA ARE SUBJECT TO CHANGE WITHOUT NOTICE TO IMPROVE RELIABILITY, FUNCTION OR DESIGN OR OTHERWISE.

Vishay Intertechnology, Inc., its affiliates, agents, and employees, and all persons acting on its or their behalf (collectively, "Vishay"), disclaim any and all liability for any errors, inaccuracies or incompleteness contained in any datasheet or in any other disclosure relating to any product.

Vishay makes no warranty, representation or guarantee regarding the suitability of the products for any particular purpose or the continuing production of any product. To the maximum extent permitted by applicable law, Vishay disclaims (i) any and all liability arising out of the application or use of any product, (ii) any and all liability, including without limitation special, consequential or incidental damages, and (iii) any and all implied warranties, including warranties of fitness for particular purpose, non-infringement and merchantability.

Statements regarding the suitability of products for certain types of applications are based on Vishay's knowledge of typical requirements that are often placed on Vishay products in generic applications. Such statements are not binding statements about the suitability of products for a particular application. It is the customer's responsibility to validate that a particular product with the properties described in the product specification is suitable for use in a particular application. Parameters provided in datasheets and / or specifications may vary in different applications and performance may vary over time. All operating parameters, including typical parameters, must be validated for each customer application by the customer's technical experts. Product specifications do not expand or otherwise modify Vishay's terms and conditions of purchase, including but not limited to the warranty expressed therein.

Hyperlinks included in this datasheet may direct users to third-party websites. These links are provided as a convenience and for informational purposes only. Inclusion of these hyperlinks does not constitute an endorsement or an approval by Vishay of any of the products, services or opinions of the corporation, organization or individual associated with the third-party website. Vishay disclaims any and all liability and bears no responsibility for the accuracy, legality or content of the third-party website or for that of subsequent links.

Except as expressly indicated in writing, Vishay products are not designed for use in medical, life-saving, or life-sustaining applications or for any other application in which the failure of the Vishay product could result in personal injury or death. Customers using or selling Vishay products not expressly indicated for use in such applications do so at their own risk. Please contact authorized Vishay personnel to obtain written terms and conditions regarding products designed for such applications.

No license, express or implied, by estoppel or otherwise, to any intellectual property rights is granted by this document or by any conduct of Vishay. Product names and markings noted herein may be trademarks of their respective owners.