

Low Power, High Sensitivity, I²C Ambient Light Sensor

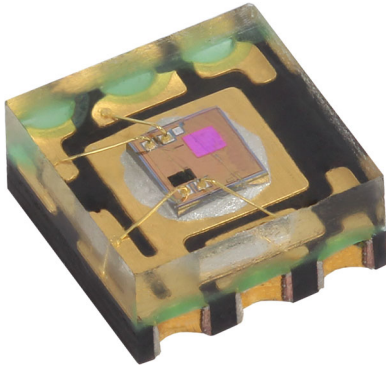

DESCRIPTION

VEML3235 is an advanced ambient light sensor with I²C protocol interface and is designed by the CMOS process. It is easy to operate via a simple I²C command.

VEML3235 incorporates a photodiode, amplifiers, and analog circuits in a single chip. The best spectral sensitivity is used to closely capture real human eye responses. VEML3235 has excellent temperature compensation and the robust refresh rate setting does not need an external RC low pass filter. Software shutdown mode is provided, which reduces power consumption to be less than 1 μ A. VEML3235's operating voltage ranges from 2.6 V to 3.6 V. VEML3235 can detect a wide range of ambient light power.

FEATURES

- Package type: surface-mount
- Dimensions (L x W x H in mm): 2 x 2 x 0.87
- Integrated modules: ambient light sensor (ALS)
- Supply voltage range V_{DD}: 2.6 V to 3.6 V
- Communication via I²C interface
- I²C bus H-level range: 1.7 V to 3.6 V
- Floor life: 168 h, MSL 3, according to J-STD-020
- Low stand by current consumption: typ. 1 μ A
- Material categorization: for definitions of compliance please see www.vishay.com/doc?99912



APPLICATIONS

- Handheld device
- Notebook
- Consumer device
- Industrial and medical application
- Computing, and industrial devices and displays

AMBIENT LIGHT FUNCTION

- High ALS sensitivity with minimum detectable intensity of 0.0021 lx/cnt supports low transmittance lens design
- Excellent temperature compensation
- High dynamic detection resolution
- Software shutdown mode control

PRODUCT SUMMARY						
PART NUMBER	OPERATING VOLTAGE RANGE (V)	I ² C BUS VOLTAGE RANGE (V)	AMBIENT LIGHT RANGE (lx)	AMBIENT LIGHT RESOLUTION (lx)	OUTPUT CODE	ADC RESOLUTION PROXIMITY / AMBIENT LIGHT
VEML3235	2.6 to 3.6	1.7 to 3.6	0.0021 to 17 867	0.0021	16 bit, I ² C	- / 16 bit

ORDERING INFORMATION			
ORDERING CODE	PACKAGING	VOLUME ⁽¹⁾	REMARKS
VEML3235	Tape and reel	MOQ: 3000	2.00 mm x 2.00 mm x 0.87 mm

Note

⁽¹⁾ MOQ: minimum order quantity

ABSOLUTE MAXIMUM RATINGS ($T_{amb} = 25\text{ }^{\circ}\text{C}$, unless otherwise specified)					
PARAMETER	TEST CONDITION	SYMBOL	MIN.	MAX.	UNIT
Supply voltage		V_{DD}	0	4	V
Operation temperature range		T_{amb}	-25	+85	$^{\circ}\text{C}$
Storage temperature range		T_{stg}	-25	+85	$^{\circ}\text{C}$

BASIC CHARACTERISTICS ($T_{amb} = 25\text{ }^{\circ}\text{C}$, unless otherwise specified)						
PARAMETER	TEST CONDITION	SYMBOL	MIN.	TYP.	MAX.	UNIT
Supply voltage		V_{DD}	2.6	3.3	3.6	V
Shut down current ⁽¹⁾	V_{DD} is 3.3 V	I_{sd}	-	1	-	μA
Supply current ⁽¹⁾	V_{DD} is 3.3 V	I_{DD}	-	250	-	μA
I ² C clock rate range		f_{SCL}	10	-	400	kHz
I ² C bus input H-level range	V_{DD} is 3.3 V	V_{ih}	1.2	-	-	V
I ² C bus input L-level range	V_{DD} is 3.3 V	V_{il}	0	-	0.4	V
Digital resolution (LSB count) ⁽²⁾	With DG = x 2, Gain = x 4		-	0.0021	-	lx/step
Detectable minimum illuminance ⁽²⁾	With DG = x 2, Gain = x 4	$E_{V\ min.}$	-	0.0021	-	lx
Detectable maximum illuminance ⁽³⁾	With DG = x 1, Gain = x 1	$E_{V\ max.}$	-	17 867	-	lx

Notes

- (1) $V_{DD} = 3.3\text{ V}$, temperature: $25\text{ }^{\circ}\text{C}$
 (2) $IT = 800\text{ ms}$
 (3) $IT = 50\text{ ms}$

CIRCUIT BLOCK DIAGRAM

Fig. 1 - Block Diagram

I²C TIMING CHARACTERISTICS ($T_{amb} = 25\text{ }^{\circ}\text{C}$, unless otherwise specified)						
PARAMETER	SYMBOL	STANDARD MODE ⁽¹⁾		FAST MODE ⁽¹⁾		UNIT
		MIN.	MAX.	MIN.	MAX.	
Clock frequency	$f_{(SMBCLK)}$	10	100	10	400	kHz
Bus free time between start and stop condition	$t_{(BUF)}$	4.7	-	1.3	-	μs
Hold time after (repeated) start condition; after this period, the first clock is generated	$t_{(HDSTA)}$	4.0	-	0.6	-	μs
Repeated start condition setup time	$t_{(SUSTA)}$	4.7	-	0.6	-	μs
Stop condition setup time	$t_{(SUSTO)}$	4.0	-	0.6	-	μs
Data hold time	$t_{(HDDAT)}$	-	3450	-	900	ns
Data setup time	$t_{(SUDAT)}$	250	-	100	-	ns
I ² C clock (SCL) low period	$t_{(LOW)}$	4.7	-	1.3	-	μs
I ² C clock (SCL) high period	$t_{(HIGH)}$	4.0	-	0.6	-	μs
Clock / data fall time	$t_{(F)}$	-	300	-	300	ns
Clock / data rise time	$t_{(R)}$	-	1000	-	300	ns

Note

⁽¹⁾ Data based on standard I²C protocol requirement, not tested in production

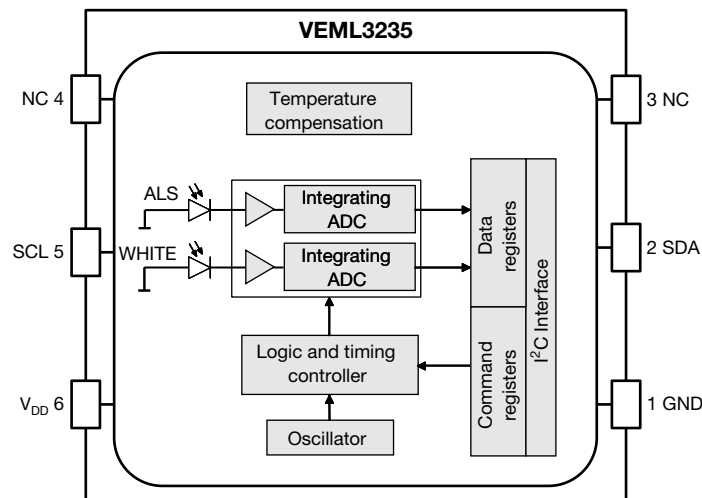
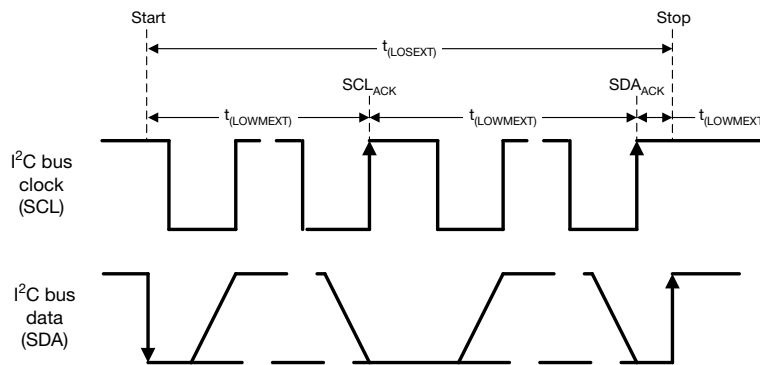
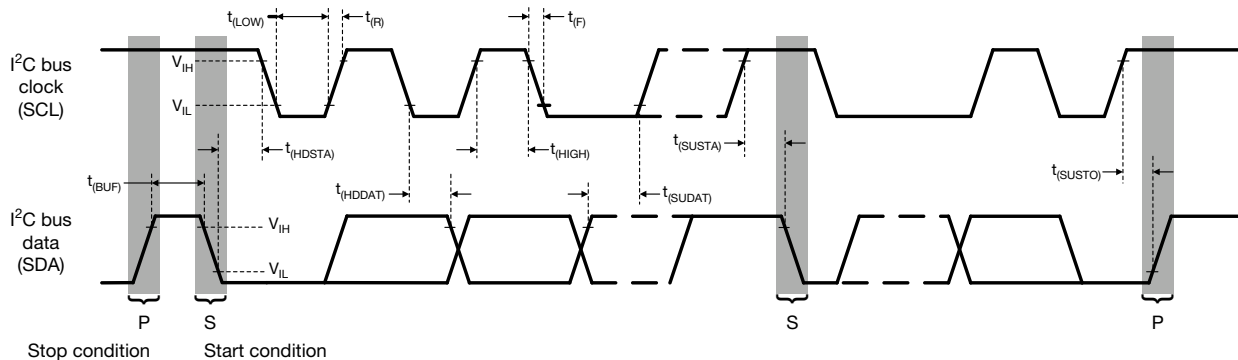
 Fig. 2 - I²C Timing Diagram

PARAMETER TIMING INFORMATION

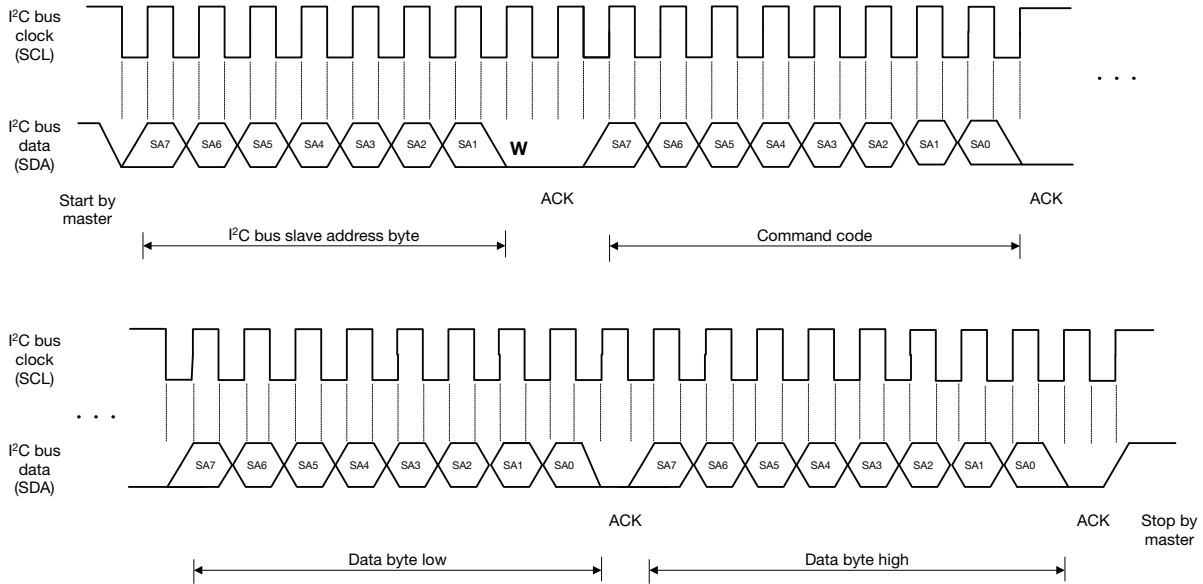

Fig. 3 - I²C Bus Timing for Sending Word Command Format

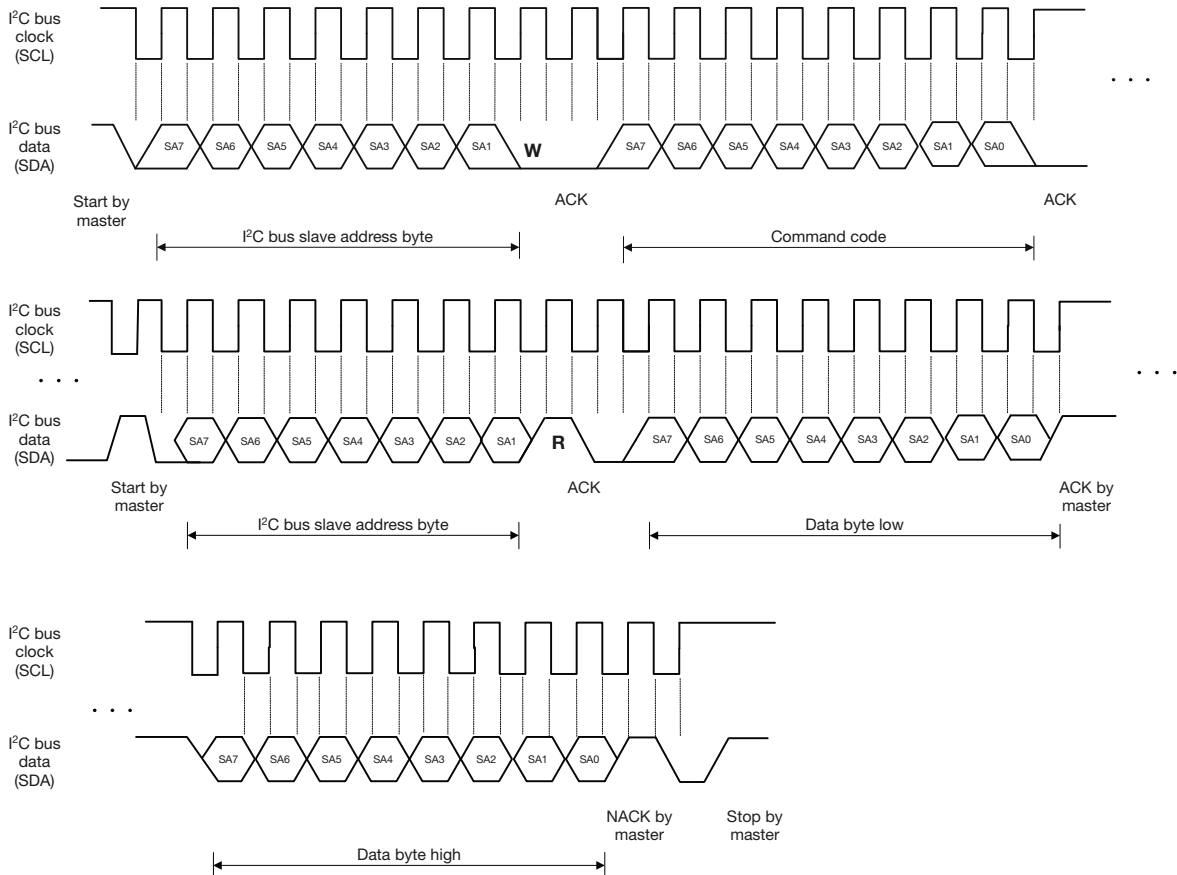

Fig. 4 - I²C Bus Timing for Receive Word Command Format

BASIC CHARACTERISTICS ($T_{amb} = 25\text{ }^{\circ}\text{C}$, unless otherwise specified)

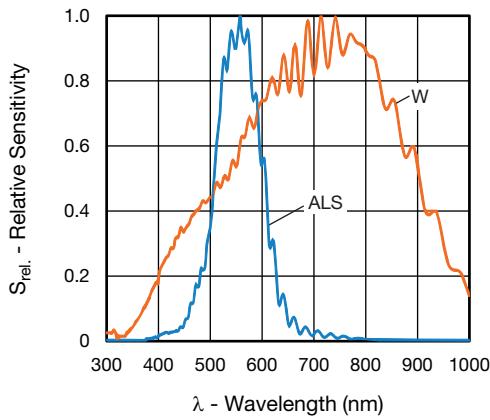

Fig. 5 - Relative Spectral Sensitivity vs. Wavelength

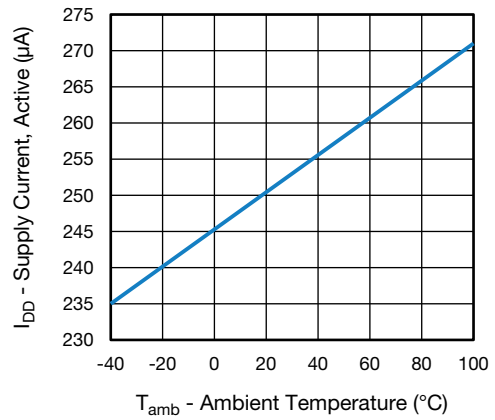

Fig. 7 - Supply Current vs. Ambient Temperature

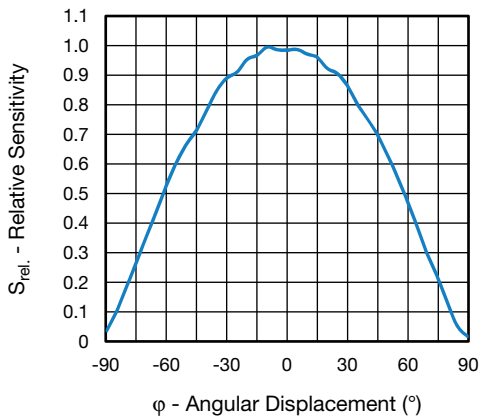

Fig. 6 - Relative Sensitivity vs. Angular Displacement

APPLICATION INFORMATION
1. Pin Connection With the Host

VEML3235 is a cost effective solution with I²C interface. The standard serial digital interface easily accesses “light intensity” without using complex calculations and programming by an external controller.

The additional capacitor near the V_{DD} pin in the circuit is used for power supply noise rejection. The value is recommended at 0.1 μF. The pull-high resistors for the I²C bus design are recommended to be 2.2 kΩ.

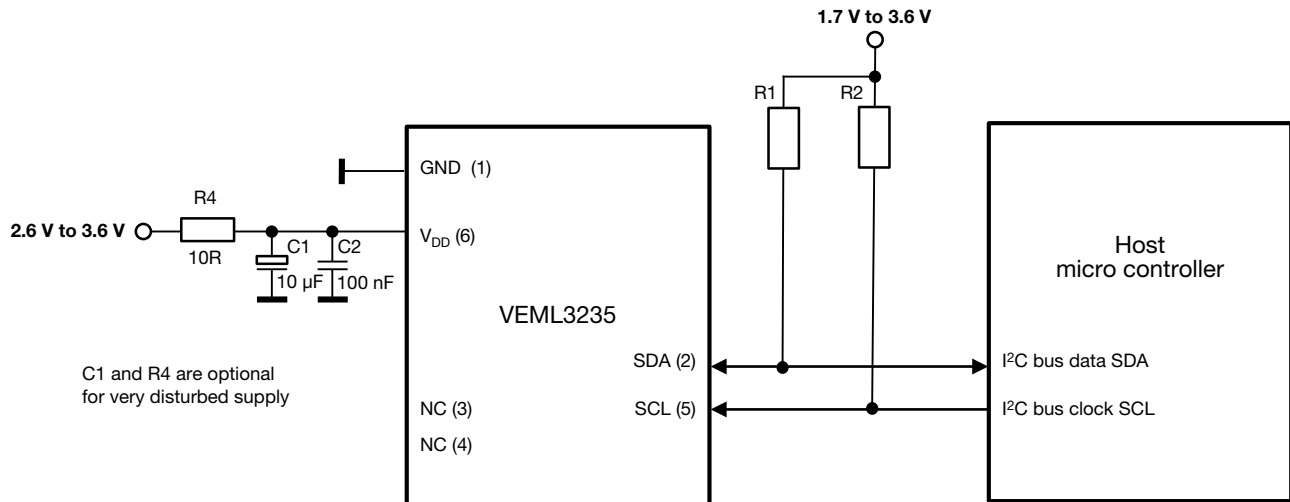
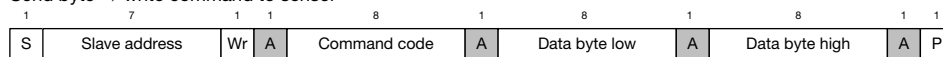

Fig. 8 - Hardware Pin Connection Diagram (Slave Address 0x10)

Digital Interface

VEML3235 contains a command register written via the I²C bus. All operations can be controlled by the command register. The simple command structure allows the user to easily program the operation setting and latch the light data from VEML3235. VEML3235's I²C command format description for read and write operations between VEML3235 and the host is shown in Fig. 9. The white areas indicate the host activity and the gray areas indicate VEML3235's acknowledgement of the host access activity.

Send byte → write command to sensor



Receive byte → read data from VEML3235

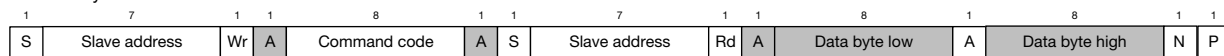

S = start condition
 P = stop condition
 A = acknowledge
 N = not acknowledge
 Host action
 Sensor acknowledge

Fig. 9 - Command Protocol Format



Command Register Format

VEML3235 uses 0x10 slave address for 7-bit I²C addressing protocol. VEML3235 has 16-bit resolution for each channel (ALS and W).

TABLE 1 - COMMAND CODE DESCRIPTION					
COMMAND CODE	REGISTER NAME	DATE BYTE LOW / HIGH	BIT	FUNCTION DESCRIPTION	R / W
0x00	Reserved	L	7	Set 0	R / W
	ALS/W_IT		6 : 4	ALS/W integration time setting (0 : 0 : 0) = 50 ms (0 : 0 : 1) = 100 ms (0 : 1 : 0) = 200 ms (0 : 1 : 1) = 400 ms (1 : 0 : 0) = 800 ms	
	Reserved		3 : 1	Set 0	
	SD		0	Shutdown BG and LDO with SD = 1 (default)	
	SD0	H	7	Shutdown ALS and white channel with SD0 = 1 (default)	
	Reserved		6	Set 0	
	DG		5	0 = x 1, 1 = x 2	
	Gain		4 : 3	(0 : 0) = x 1 (0 : 1) = x 2 (1 : 0) = reserved (1 : 1) = x 4	
	Reserved		2 : 1	Set 0	
	Reserved		0	Set 1	
	Reserved				
0x02	Reserved	L	7 : 0	Set 0	
	Reserved	H	7 : 0	Set 0	
0x04	W_LSB	L	7 : 0	W LSB data	R
	W_MSB	H	7 : 0	W MSB data	
0x05	ALS_LSB	L	7 : 0	ALS LSB data	
	ALS_MSB	H	7 : 0	ALS MSB data	
0x09	ID_L	L	7 : 0	ID part number: 3235 = 0011 0101	
	Reserved	H	7 : 0	Reserved	

Data Access

VEML3235 has 16-bit high resolution sensitivity for each channel. To represent the 16-bit data, it has to apply two bytes. One byte is for LSB and the other byte is for MSB. The host needs to follow the read word protocol. The data format shows as below.

TABLE 2 - 16-BIT DATA FORMAT																
VEML3235 16-BIT DATA FORMAT																
Data bit	15	14	13	12	11	10	9	8	7	6	5	4	3	2	1	0
Data byte low									←————→							
Data byte high	←————→															

Note

S	Slave address	Wr	A	Command code	A	S	Slave address	Rd	A	Data byte low	A	Data byte high	N	P
---	---------------	----	---	--------------	---	---	---------------	----	---	---------------	---	----------------	---	---

- Data byte low represents LSB and data byte high represents MSB

The table below shows these dependencies:

RESOLUTION AND MAXIMUM DETECTION RANGE AT DG = 1							
	GAIN: x 4	GAIN: x 2	GAIN: x 1		GAIN: x 4	GAIN: x 2	GAIN: x 1
IT (ms)	TYPICAL RESOLUTION (lx/cnt)				MAXIMUM POSSIBLE ILLUMINATION (lx)		
800	0.00426	0.00852	0.01704		279	558	1117
400	0.00852	0.01704	0.03408		558	1117	2233
200	0.01704	0.03408	0.06816		1117	2233	4467
100	0.03408	0.06816	0.13632		2233	4467	8934
50	0.06816	0.13632	0.27264		4467	8934	17 867

RESOLUTION AND MAXIMUM DETECTION RANGE AT DG = 2							
	GAIN: x 4	GAIN: x 2	GAIN: x 1		GAIN: x 4	GAIN: x 2	GAIN: x 1
IT (ms)	TYPICAL RESOLUTION (lx/cnt)				MAXIMUM POSSIBLE ILLUMINATION (lx)		
800	0.00213	0.00426	0.00852		140	279	558
400	0.00426	0.00852	0.01704		279	558	1117
200	0.00852	0.01704	0.03408		558	1117	2233
100	0.01704	0.03408	0.06816		1117	2233	4467
50	0.03408	0.06816	0.13632		2233	4467	8934

Example:

If the 16-bit word of the ALS data shows: 0000 0101 1100 1000 = 1480 (dec.), the programmed Gain = x 1, the digital gain DG = x 1 and the integration time is 100 ms, the corresponding lux level is: light level [lx] = 1480 x 0.13632 = 202 lx.

For detailed description about set-up and more application related information see application note: "Designing VEML3235 into an Application".

PACKAGE INFORMATION in millimeters

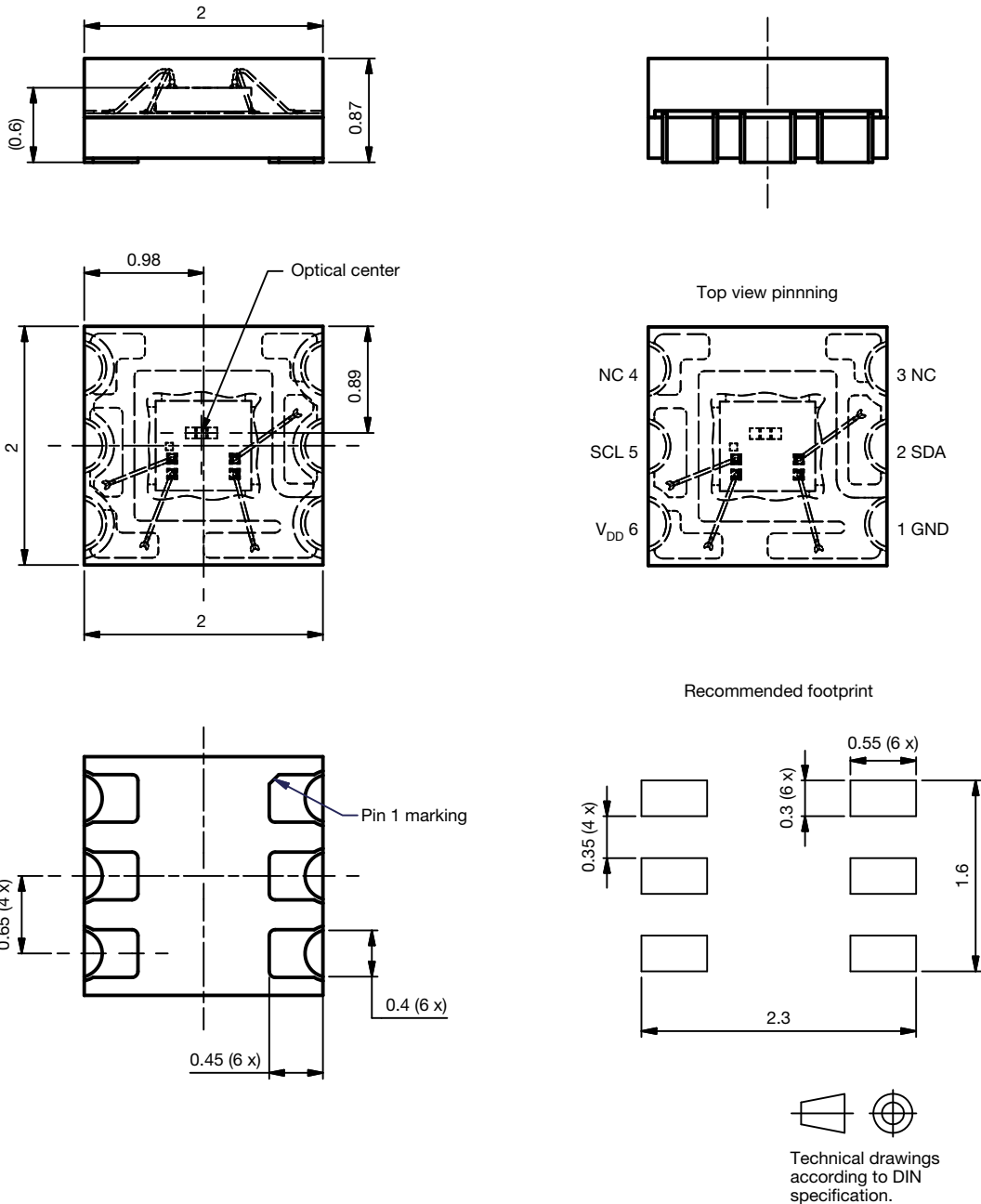

Drawing No. 18-2015-122-01-4

Not indicated tolerances ± 0.1

Fig. 10 - VEML3235 A3OZ Package Dimensions

TAPE AND REEL DIMENSIONS in millimeters

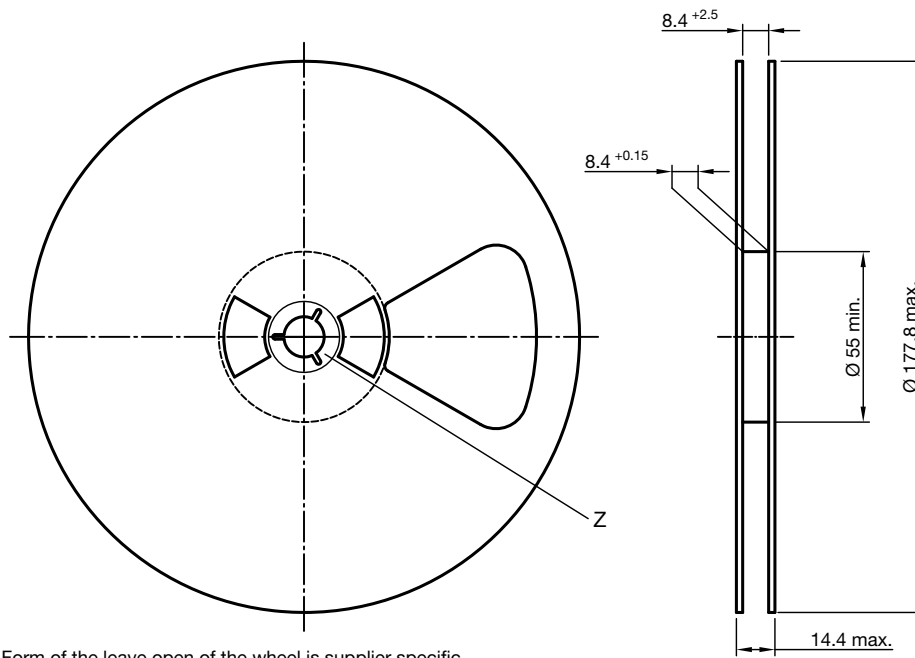

Form of the leave open of the wheel is supplier specific.

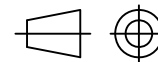
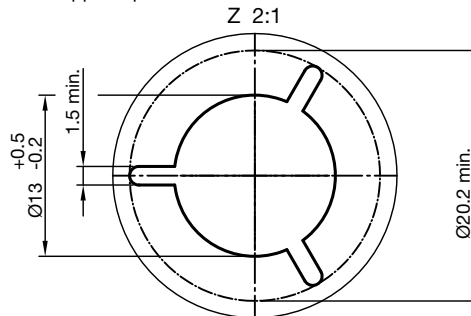

Technical drawings according to DIN specification.

Drawing-No.: 9.800-5096.01-4
Issue: 6; 20.03.2019

Fig. 11 - 7" Reel, 3000 Pieces

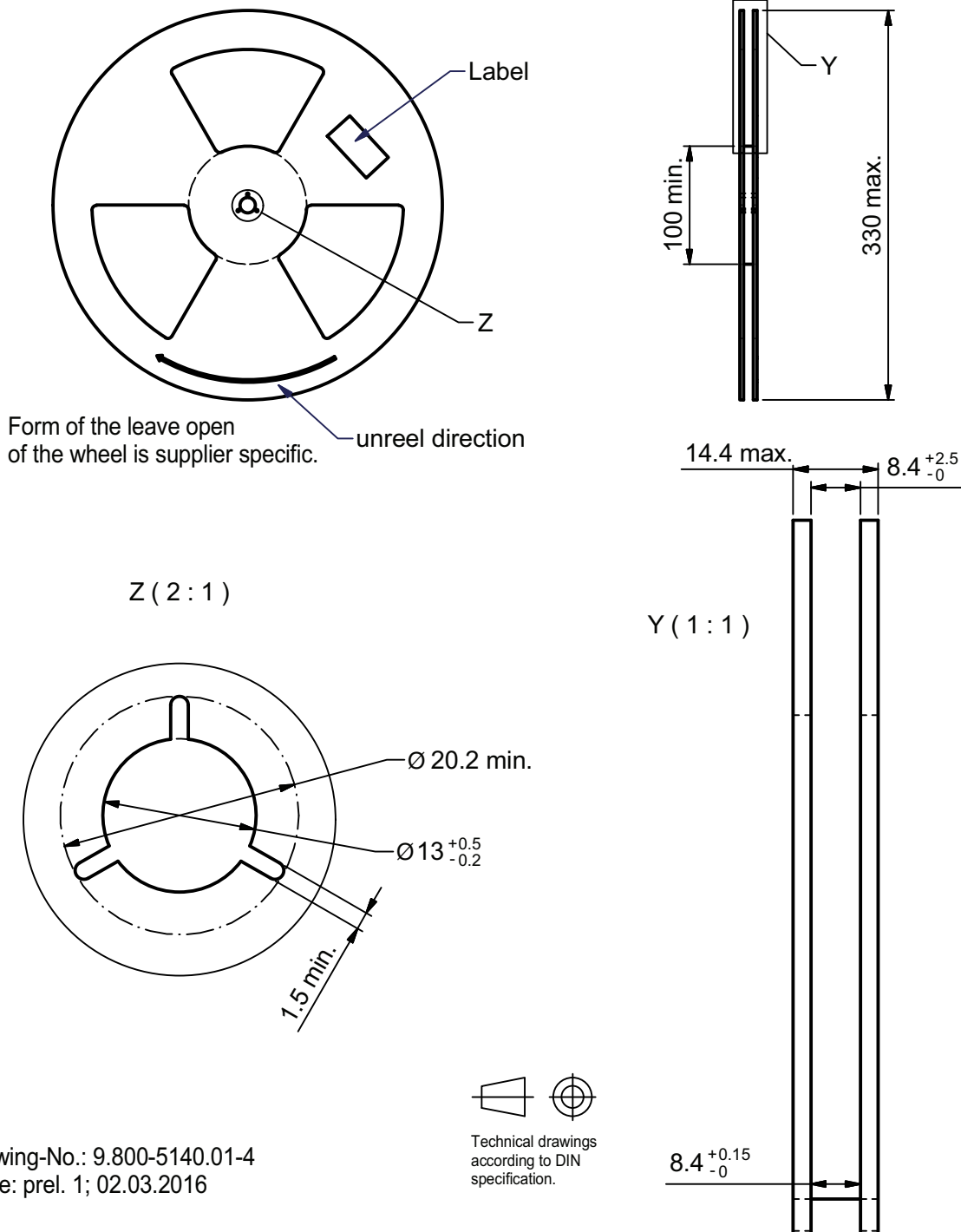

Drawing-No.: 9.800-5140.01-4
Issue: prel. 1; 02.03.2016

Fig. 12 - 13" Reel, 10 000 Pieces

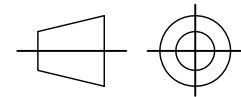
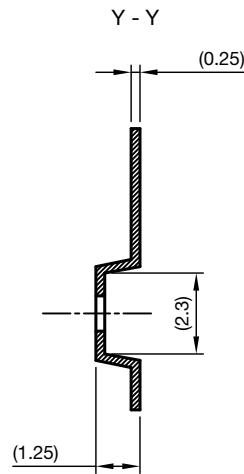
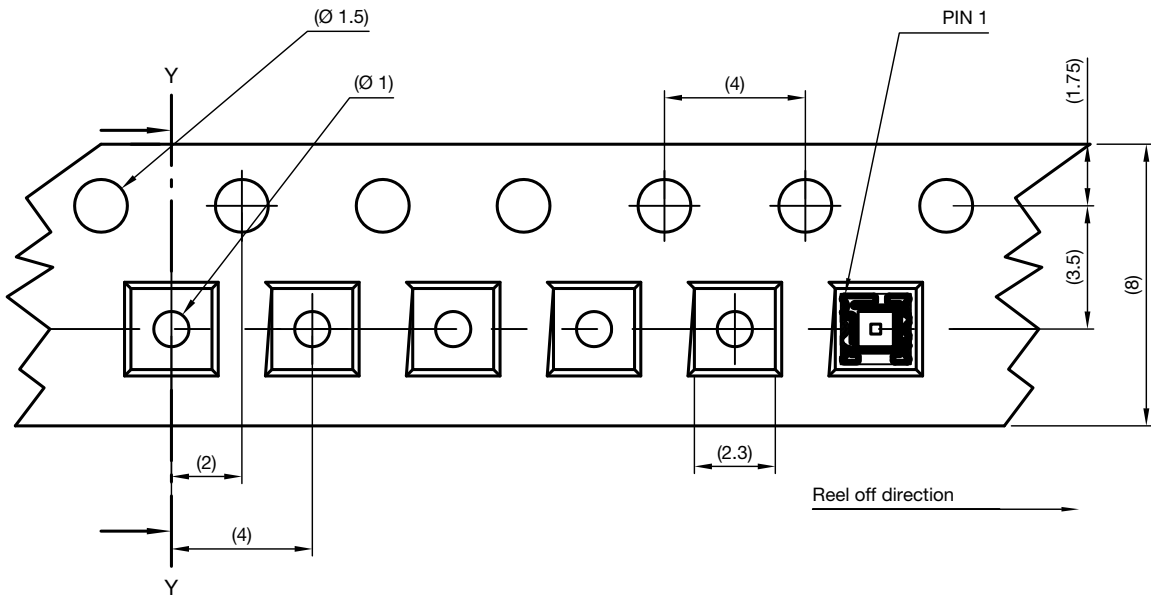

technical drawings
according to DIN
specifications

Drawing-No.: 9.700-5397.01-4
Issue: 1; 19.02.16

Fig. 13 - Taping



RECOMMENDED STORAGE AND REBAKING CONDITIONS				
PARAMETER	CONDITIONS	MIN.	MAX.	UNIT
Storage temperature		5	50	°C
Relative humidity		-	60	%
Open time		-	168	h
Total time	From the date code on the aluminized envelope (unopened)	-	12	months
Rebaking	Tape and reel: 60 °C	-	22	h
	Tube: 60 °C	-	22	h

RECOMMENDED INFRARED REFLOW

Soldering conditions which are based on J-STD-020 C

IR REFLOW PROFILE CONDITION			
PARAMETER	CONDITIONS	TEMPERATURE	TIME
Peak temperature		255 °C + 0 °C / - 5 °C (max.: 260 °C)	10 s
Preheat temperature range and timing		150 °C to 200 °C	60 s to 180 s
Timing within 5 °C to peak temperature		-	10 s to 30 s
Timing maintained above temperature / time		217 °C	60 s to 150 s
Timing from 25 °C to peak temperature		-	8 min (max.)
Ramp-up rate		3 °C/s (max.)	-
Ramp-down rate		6 °C/s (max.)	-

Recommend Normal Solder Reflow is 235 °C to 255 °C

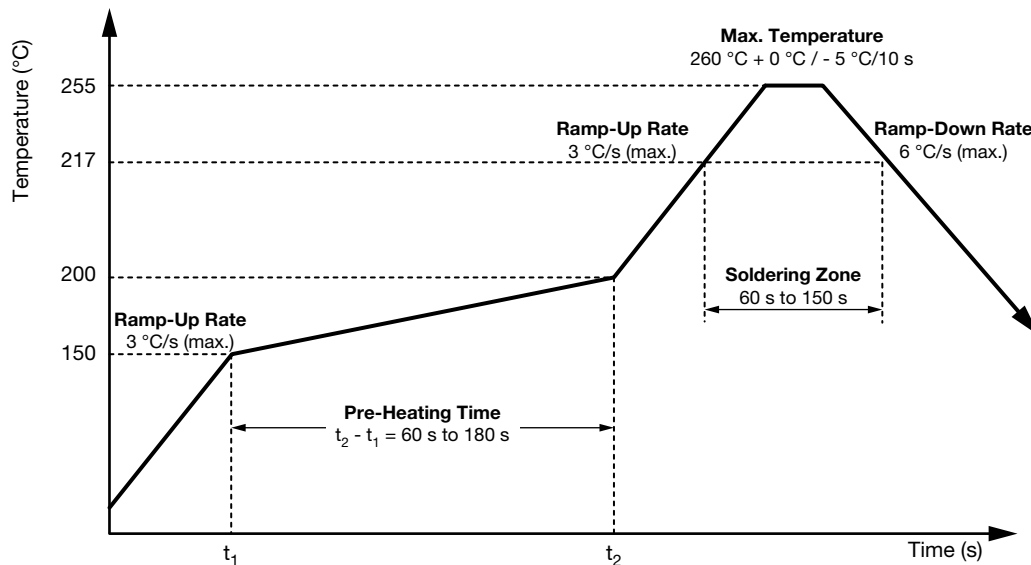

Fig. 14 - VEML3235SL Solder Reflow Profile Chart



DRYPACK

Devices are packed in moisture barrier bags (MBB) to prevent the products from moisture absorption during transportation and storage. Each bag contains a desiccant.

FLOOR LIFE

Floor life (time between soldering and removing from MBB) must not exceed the time indicated on MBB label:

Floor life: 168 h

Conditions: $T_{amb} < 30\text{ }^{\circ}\text{C}$, $\text{RH} < 60\text{ } \%$

Moisture sensitivity level 3, according to J-STD-020.

DRYING

In case of moisture absorption devices should be baked before soldering. Conditions see J-STD-020 or label. Devices taped on reel dry using recommended conditions 192 h at $40\text{ }^{\circ}\text{C}$ (+ $5\text{ }^{\circ}\text{C}$), $\text{RH} < 5\text{ } \%$.



Disclaimer

ALL PRODUCT, PRODUCT SPECIFICATIONS AND DATA ARE SUBJECT TO CHANGE WITHOUT NOTICE TO IMPROVE RELIABILITY, FUNCTION OR DESIGN OR OTHERWISE.

Vishay Intertechnology, Inc., its affiliates, agents, and employees, and all persons acting on its or their behalf (collectively, "Vishay"), disclaim any and all liability for any errors, inaccuracies or incompleteness contained in any datasheet or in any other disclosure relating to any product.

Vishay makes no warranty, representation or guarantee regarding the suitability of the products for any particular purpose or the continuing production of any product. To the maximum extent permitted by applicable law, Vishay disclaims (i) any and all liability arising out of the application or use of any product, (ii) any and all liability, including without limitation special, consequential or incidental damages, and (iii) any and all implied warranties, including warranties of fitness for particular purpose, non-infringement and merchantability.

Statements regarding the suitability of products for certain types of applications are based on Vishay's knowledge of typical requirements that are often placed on Vishay products in generic applications. Such statements are not binding statements about the suitability of products for a particular application. It is the customer's responsibility to validate that a particular product with the properties described in the product specification is suitable for use in a particular application. Parameters provided in datasheets and / or specifications may vary in different applications and performance may vary over time. All operating parameters, including typical parameters, must be validated for each customer application by the customer's technical experts. Product specifications do not expand or otherwise modify Vishay's terms and conditions of purchase, including but not limited to the warranty expressed therein.

Hyperlinks included in this datasheet may direct users to third-party websites. These links are provided as a convenience and for informational purposes only. Inclusion of these hyperlinks does not constitute an endorsement or an approval by Vishay of any of the products, services or opinions of the corporation, organization or individual associated with the third-party website. Vishay disclaims any and all liability and bears no responsibility for the accuracy, legality or content of the third-party website or for that of subsequent links.

Vishay products are not designed for use in life-saving or life-sustaining applications or any application in which the failure of the Vishay product could result in personal injury or death unless specifically qualified in writing by Vishay. Customers using or selling Vishay products not expressly indicated for use in such applications do so at their own risk. Please contact authorized Vishay personnel to obtain written terms and conditions regarding products designed for such applications.

No license, express or implied, by estoppel or otherwise, to any intellectual property rights is granted by this document or by any conduct of Vishay. Product names and markings noted herein may be trademarks of their respective owners.