

High Speed Optocoupler, 10 MBd

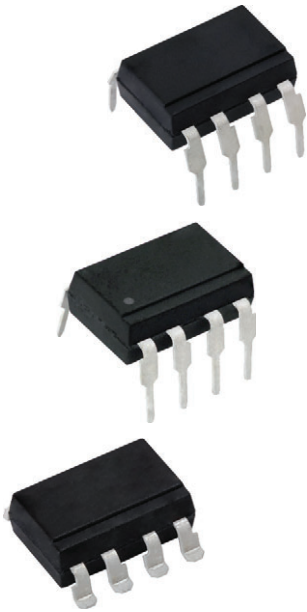

DESCRIPTION

The VOH61A is a low power consumption single channel 10 MBd high speed optocoupler in low power CMOS technology. Utilizing a high speed IRED on the input coupled with an integrated optical detector IC on the output. The digital output interface, in combination with the very low pulse width distortion of 7 ns and the high noise immunity of 50 kV/μs, enable an easy integration into digital logic systems.

FEATURES

- CMOS logic digital input and output
- High speed data rate of 10 MBd
- Wide supply voltage range 2.7 V to 5.5 V
- Low 1 mA detector current consumption
- Material categorization: for definitions of compliance please see www.vishay.com/doc?99912



RoHS
COMPLIANT

APPLICATIONS

- Galvanic isolation in digital systems
- Ground loop elimination
- PLC and ATE interface isolation
- Digital bus system isolation
- Feedback control in digital power supplies

AGENCY APPROVALS

- UL (pending)
- cUL (pending)
- DIN EN 60747-5-5 (VDE 0884-5), available with option 1 (pending)

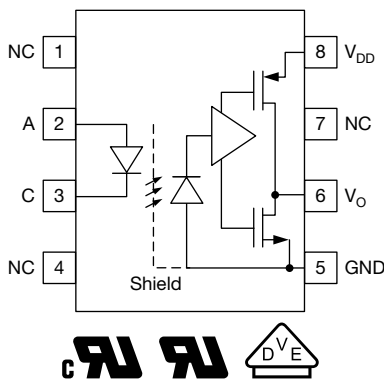

ORDERING INFORMATION

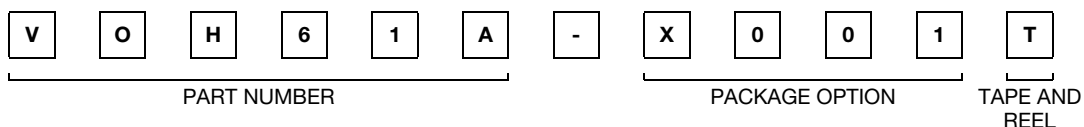

AGENCY CERTIFIED / PACKAGE

AGENCY CERTIFIED / PACKAGE	
UL, cUL	
DIP-8	VOH61A
DIP-8, 400 mil	VOH61A-X006
SMD-8	VOH61A-X007T
UL, cUL, VDE (with option 1)	
DIP-8	VOH61A-X001
DIP-8, 400 mil	VOH61A-X016
SMD-8	VOH61A-X017T

Note

- Additional options may be possible, please contact sales office



TRUTH TABLE (positive logic)	
INPUT	OUTPUT
H	L
L	H

ABSOLUTE MAXIMUM RATINGS ($T_{amb} = 25\text{ }^{\circ}\text{C}$, unless otherwise specified)				
PARAMETER	TEST CONDITION	SYMBOL	VALUE	UNIT
INPUT				
Average forward current		I_F	20	mA
Surge current	$t = 100\text{ }\mu\text{s}$	I_{FSM}	1	A
Reverse input voltage		V_R	5	V
Input power dissipation		P_{diss}	40	mW
OUTPUT				
Supply voltage		V_{DD}	-0.5 to 6	V
Output voltage		V_O	-0.5 to $V_{DD} + 0.5$	V
Output current		I_O	10	mA
Output power dissipation		P_{diss}	55	mW
COUPLER				
Storage temperature		T_{stg}	-55 to +150	$^{\circ}\text{C}$
Operating temperature		T_{amb}	-40 to +110	$^{\circ}\text{C}$
Lead solder temperature	for 10 s		260	$^{\circ}\text{C}$
Solder reflow temperature	for 1 min		260	$^{\circ}\text{C}$

Note

- Stresses in excess of the absolute maximum ratings can cause permanent damage to the device. Functional operation of the device is not implied at these or any other conditions in excess of those given in the operational sections of this document. Exposure to absolute maximum ratings for extended periods of the time can adversely affect reliability

RECOMMENDED OPERATING CONDITION				
PARAMETER	SYMBOL	MIN.	MAX.	UNIT
Operating temperature	T_{amb}	-40	+110	$^{\circ}\text{C}$
Input current low level	I_{FL}	0	0.25	mA
Input current high level	I_{FH}	5	15	mA
Output supply voltage	V_{DD}	2.7	5.5	V
Forward input voltage	$V_{F(off)}$	-	0.8	V

ELECTRICAL CHARACTERISTICS

 ($T_{amb} = -40\text{ }^{\circ}\text{C}$ to $+110\text{ }^{\circ}\text{C}$ and $V_{DD} = 2.7\text{ V}$ to 5.5 V ; typical values are at $T_{amb} = 25\text{ }^{\circ}\text{C}$ and $V_{DD} = 5\text{ V}$)

PARAMETER	TEST CONDITION	SYMBOL	MIN.	TYP.	MAX.	UNIT
INPUT						
Input forward voltage	$I_F = 10\text{ mA}$	V_F	1.1	1.4	1.7	V
Input forward voltage temperature coefficient	$I_F = 2\text{ mA}$	$\Delta V_F / \Delta T_{amb}$	-	-1.6	-	mV/ $^{\circ}\text{C}$
Input reverse current	$V_R = 5\text{ V}$	I_R	-	0.01	10	μA
Input threshold current		I_{TH}	-	2.5	5	mA
Input capacitance	$f = 1\text{ MHz}$, $V_F = 0\text{ V}$	C_I	-	55	-	pF
OUTPUT						
High level supply current	$I_F = 0\text{ mA}$	I_{DDH}	-	1	1.3	mA
Low level supply current	$I_F = 10\text{ mA}$	I_{DDL}	-	1	1.3	mA
High level output voltage	$I_F = 0\text{ mA}$, $I_O = -20\text{ }\mu\text{A}$	V_{OH}	$V_{DD} - 0.1$	V_{DD}	-	V
	$I_F = 0\text{ mA}$, $I_O = -3.2\text{ mA}$	V_{OH}	$V_{DD} - 1.0$	$V_{DD} - 0.15$	-	V
Low level output voltage	$I_F = 5\text{ mA}$, $I_O = 20\text{ }\mu\text{A}$	V_{OL}	-	0.001	0.1	V
	$I_F = 5\text{ mA}$, $I_O = 3.2\text{ mA}$	V_{OL}	-	0.15	0.4	V

Note

- Minimum and maximum values are testing requirements. Typical values are characteristics of the device and are the result of engineering evaluation. Typical values are for information only and are not part of the testing requirements

SWITCHING CHARACTERISTICS

 ($T_{amb} = -40\text{ }^{\circ}\text{C}$ to $+110\text{ }^{\circ}\text{C}$ and $V_{DD} = 2.7\text{ V}$ to 5.5 V ; typical values are at $T_{amb} = 25\text{ }^{\circ}\text{C}$ and $V_{DD} = 5\text{ V}$)

PARAMETER	TEST CONDITION	SYMBOL	MIN.	TYP.	MAX.	UNIT
Propagation delay time to high output level	$I_F = 7.5\text{ mA}$, $C_L = 15\text{ pF}$, CMOS signal levels	t_{PLH}	-	50	80	ns
Propagation delay time to low output level		t_{PHL}	-	44	80	ns
Pulse width distortion		$ t_{PHL} - t_{PLH} $	-	7	30	ns
Output rise time (10 to 90 %)		t_r	-	5	-	ns
Output fall time (90 to 10 %)		t_f	-	5	-	ns

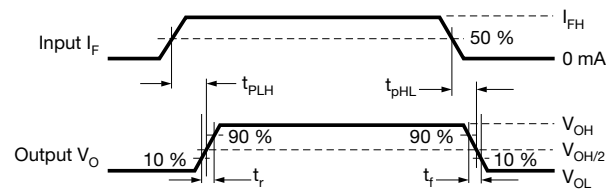
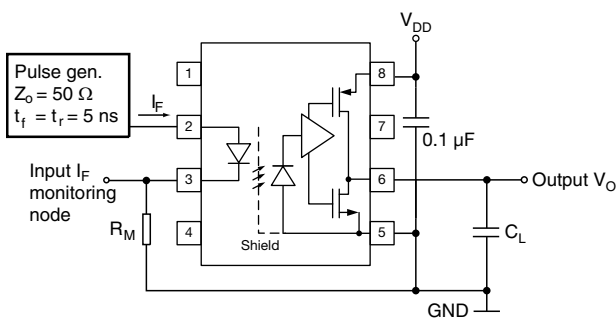
 Fig. 1 - Test Circuit for t_{PLH} , t_{PHL} , t_r and t_f

COMMON MODE TRANSIENT IMMUNITY

 ($T_{amb} = -40\text{ }^{\circ}\text{C}$ to $+110\text{ }^{\circ}\text{C}$ and $V_{DD} = 2.7\text{ V}$ to 5.5 V ; typical values are at $T_{amb} = 25\text{ }^{\circ}\text{C}$ and $V_{DD} = 5\text{ V}$)

PARAMETER	TEST CONDITION	SYMBOL	MIN.	TYP.	MAX.	UNIT
Common mode transient immunity (high)	$V_{CM} = 1000\text{ V}$, $C_L = 15\text{ pF}$, CMOS signal levels	$ CM_H $	30 000	50 000	-	V/ μs
Common mode transient immunity (low)		$ CM_L $	30 000	50 000	-	V/ μs

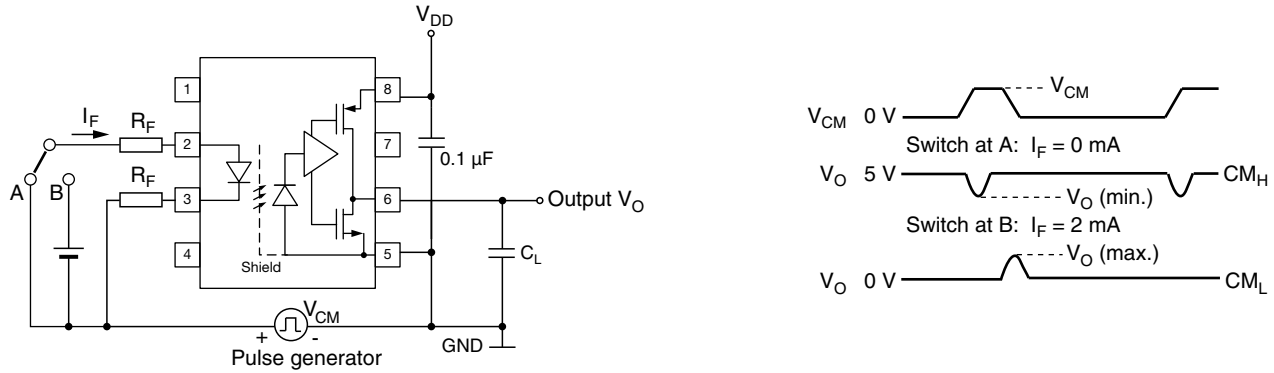

Fig. 2 - Test Circuit for Common Mode Transient Immunity

SAFETY AND INSULATION RATINGS ($T_{amb} = 25\text{ }^{\circ}\text{C}$, unless otherwise specified)

PARAMETER	TEST CONDITION	SYMBOL	VALUE	UNIT
Comparative tracking index	Insulation group IIIa	CTI	175	
Maximum rated withstanding isolation voltage	According to UL1577, $t = 1\text{ min}$	V_{ISO}	5300	V_{RMS}
Maximum transient isolation voltage	According to DIN EN 60747-5-5	V_{IOTM}	6000	V_{peak}
Maximum repetitive peak isolation voltage	According to DIN EN 60747-5-5	V_{IORM}	891	V_{peak}
Isolation resistance	$T_{amb} = 25\text{ }^{\circ}\text{C}$, $V_{IO} = 500\text{ V}$	R_{IO}	10^{12}	Ω
	$T_{amb} = 100\text{ }^{\circ}\text{C}$, $V_{IO} = 500\text{ V}$	R_{IO}	10^{11}	Ω
Output safety power		P_{SO}	250	mW
Input safety current		I_{SI}	25	mA
Input safety temperature		T_S	175	$^{\circ}\text{C}$
Creepage distance	DIP-8, SMD-8		> 7	mm
Clearance distance			> 7	mm
Creepage distance	DIP-8, 400 mil		> 8	mm
Clearance distance			> 8	mm
Insulation thickness		DTI	> 0.4	mm

Note

- As per IEC 60747-5-5, §5.5.4.9.3, this optocoupler is reinforced rated and suitable for "safe electrical insulation" only within the safety ratings. Compliance with the safety ratings shall be ensured by means of protective circuits

TYPICAL CHARACTERISTICS ($T_{amb} = 25\text{ }^{\circ}\text{C}$, unless otherwise specified)

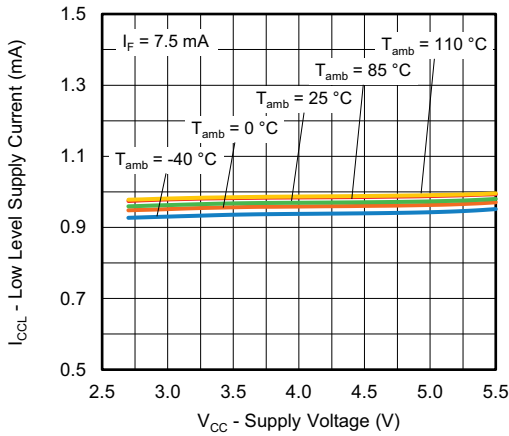

Fig. 3 - Low Level Supply Current vs. Supply Voltage

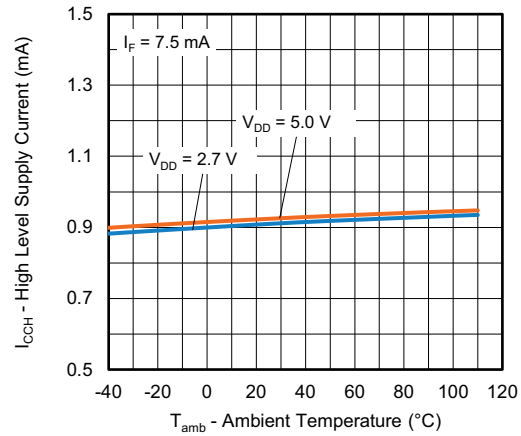

Fig. 6 - High Level Supply Current vs. Ambient Temperature

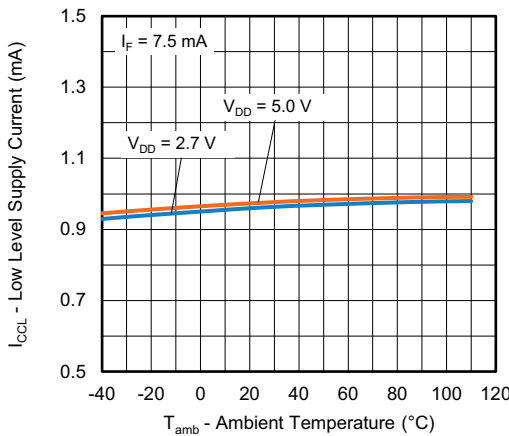

Fig. 4 - Low Level Supply Current vs. Ambient Temperature

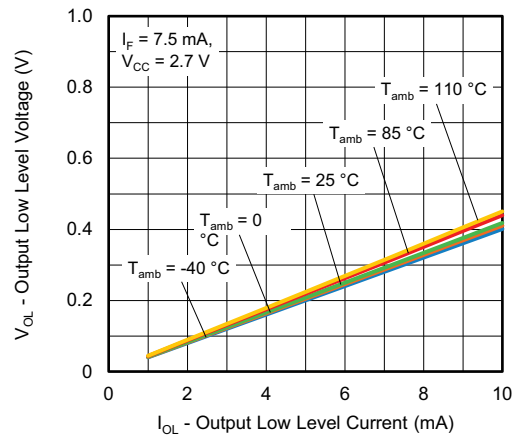

Fig. 7 - Output Low Level Voltage vs. Output Low Level Current

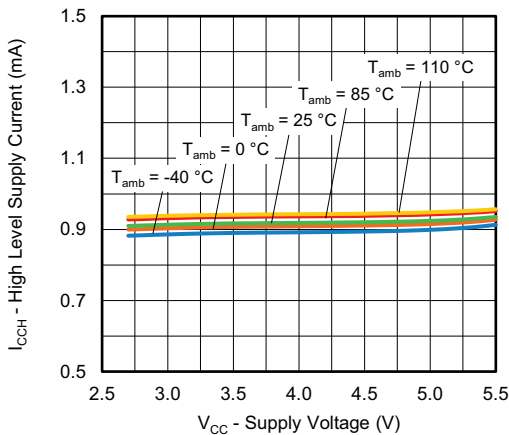

Fig. 5 - High Level Supply Current vs. Supply Voltage

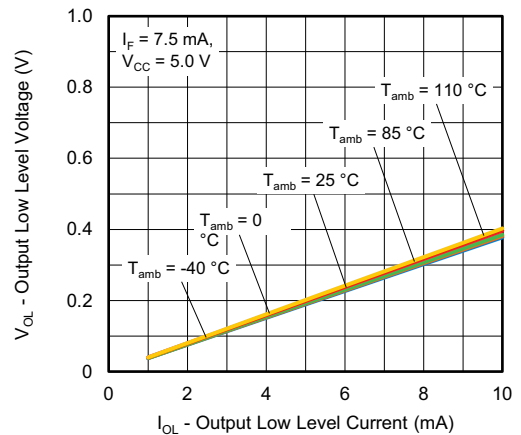

Fig. 8 - Output Low Level Voltage vs. Output Low Level Current

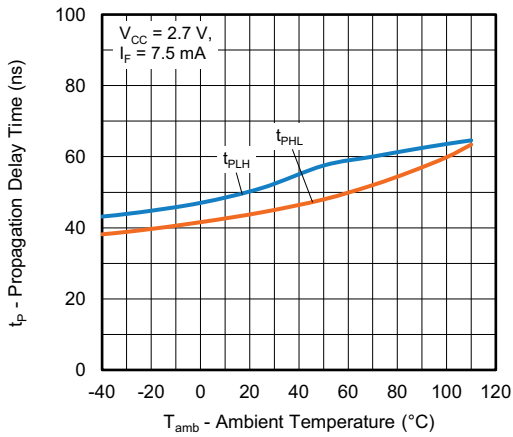

Fig. 9 - Propagation Delay Time vs. Ambient Temperature (27 V)

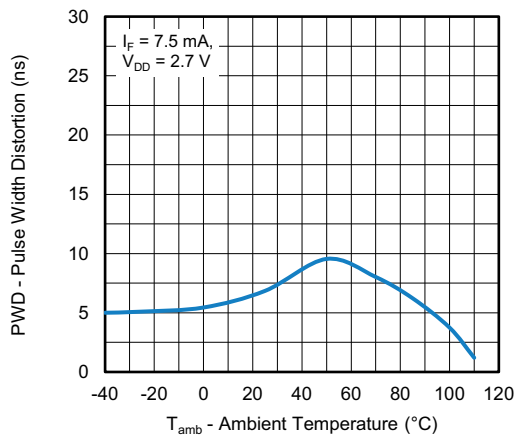

Fig. 10 - Pulse Width Distortion vs. Ambient Temperature

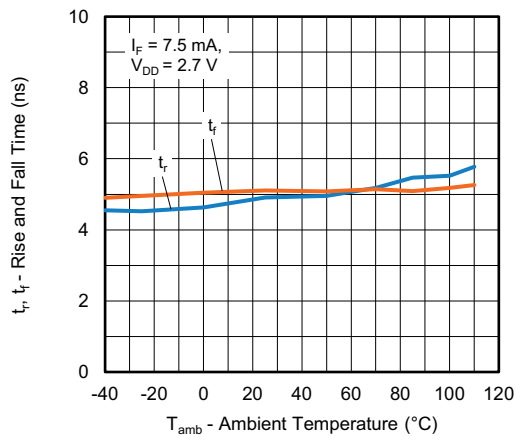
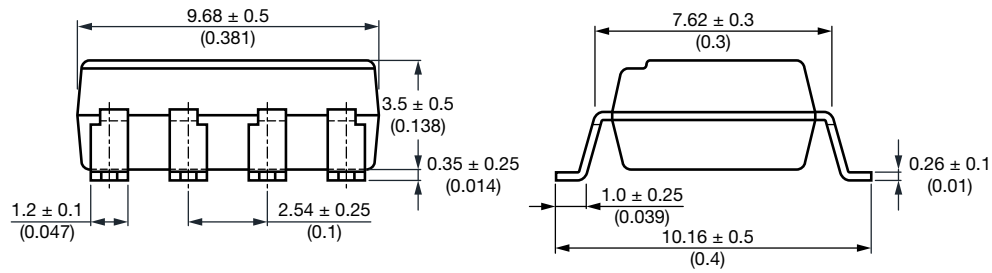
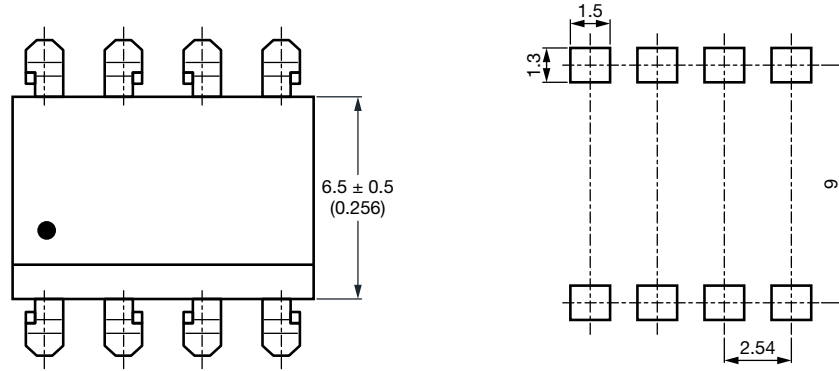

Fig. 11 - Rise and Fall Time vs. Ambient Temperature

SMD-8



23007

Fig. 14

PACKAGE MARKING

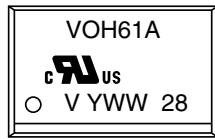

Fig. 15 - Example of VOH61A

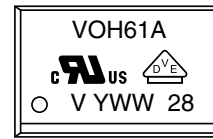

Fig. 16 - Example of VOH61A-X017T

Notes

- "YWW" is the date code marking (Y = year code, WW = week code)
- VDE logo is only marked on VDE option parts
- Tape and reel suffix (T) is not part of the package marking

PACKAGING INFORMATION (in millimeters)

DEVICES PER TUBES			
TYPE	UNITS/TUBE	TUBES/BOX	UNITS/BOX
DIP-8	50	40	2000
DIP-8, 400 mil	50	40	2000

SMD-8 Tape

Fig. 17 - Tape and Reel Packaging (1000 pieces on reel)

Reel

Fig. 18 - Tape and Reel Shipping Medium

SOLDER PROFILES
IR Reflow Soldering (JEDEC® J-STD-020C compliant)

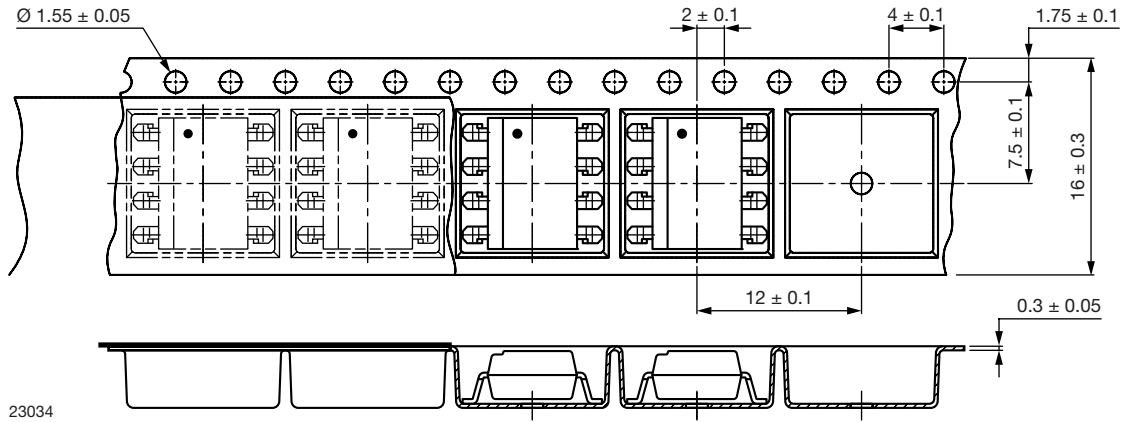
One time soldering reflow is recommended within the condition of temperature and time profile shown below. Do not solder more than three times.

PROFILE ITEM	CONDITIONS
Preheat	
- Temperature minimum ($T_{S \text{ min.}}$)	150 °C
- Temperature maximum ($T_{S \text{ max.}}$)	200 °C
- Time (min. to max.) (t_s)	90 s ± 30 s
Soldering zone	
- Temperature (T_L)	217 °C
- Time (t_L)	60 s
Peak temperature (T_p)	260 °C
Ramp-up rate	3 °C/s max.
Ramp-down rate	3 °C/s to 6 °C/s

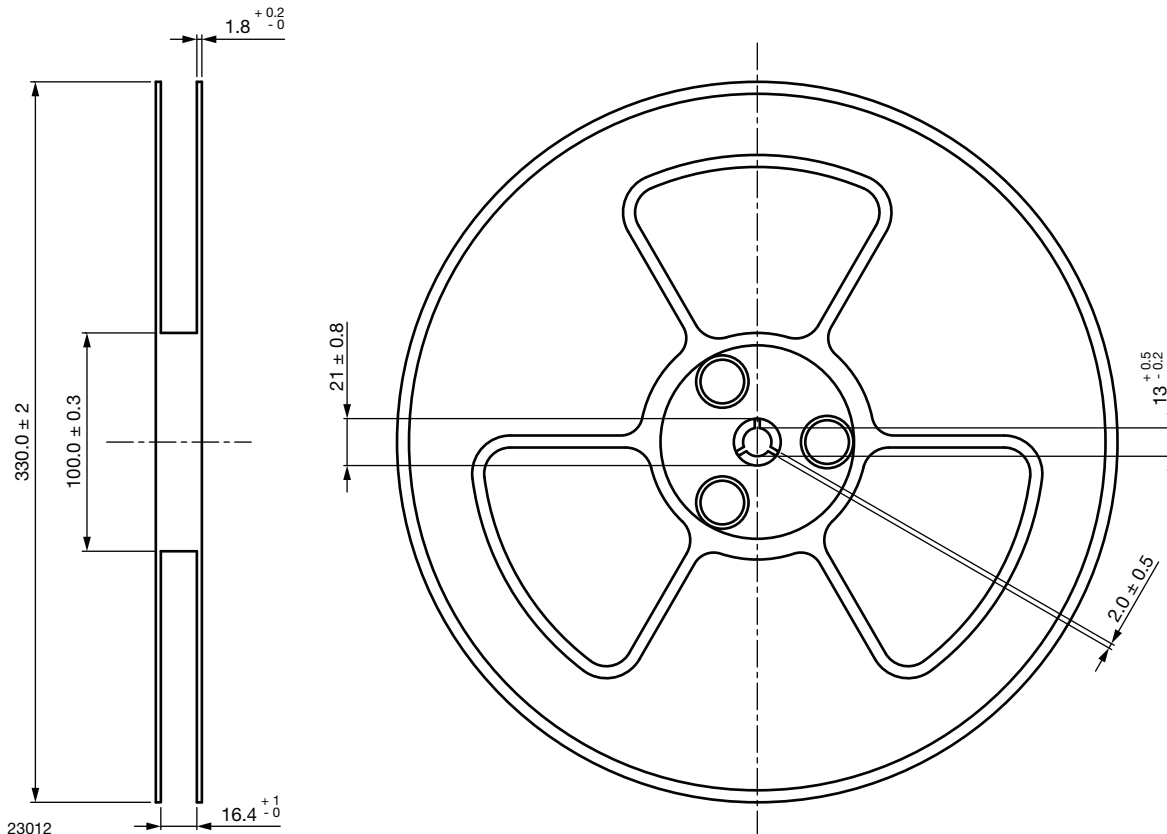
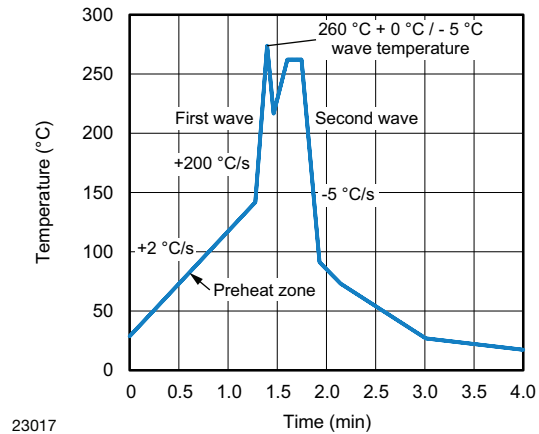

Fig. 20

23017

Hand Soldering by Soldering Iron

Allow single lead soldering in every single process. One time soldering is recommended.

Temperature: 380 °C + 0 °C / - 5 °C

Time: 3 s max.

HANDLING AND STORAGE CONDITIONS

ESD level: HBM class 2

Floor life: unlimited

Conditions: $T_{\text{amb}} < 30 \text{ °C}$, RH < 85 %

Moisture sensitivity level 1, according to J-STD-020

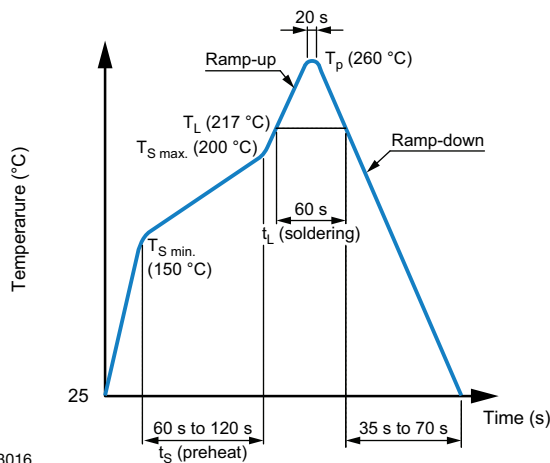

Fig. 19

23016

Wave Soldering (JEDEC JESD22-A111 compliant)

One time soldering is recommended within the condition of temperature.

Temperature: 260 °C + 0 °C / - 5 °C

Time: 10 s

Preheat temperature: 25 °C to 140 °C

Preheat time: 30 s to 80 s



Disclaimer

ALL PRODUCT, PRODUCT SPECIFICATIONS AND DATA ARE SUBJECT TO CHANGE WITHOUT NOTICE TO IMPROVE RELIABILITY, FUNCTION OR DESIGN OR OTHERWISE.

Vishay Intertechnology, Inc., its affiliates, agents, and employees, and all persons acting on its or their behalf (collectively, "Vishay"), disclaim any and all liability for any errors, inaccuracies or incompleteness contained in any datasheet or in any other disclosure relating to any product.

Vishay makes no warranty, representation or guarantee regarding the suitability of the products for any particular purpose or the continuing production of any product. To the maximum extent permitted by applicable law, Vishay disclaims (i) any and all liability arising out of the application or use of any product, (ii) any and all liability, including without limitation special, consequential or incidental damages, and (iii) any and all implied warranties, including warranties of fitness for particular purpose, non-infringement and merchantability.

Statements regarding the suitability of products for certain types of applications are based on Vishay's knowledge of typical requirements that are often placed on Vishay products in generic applications. Such statements are not binding statements about the suitability of products for a particular application. It is the customer's responsibility to validate that a particular product with the properties described in the product specification is suitable for use in a particular application. Parameters provided in datasheets and / or specifications may vary in different applications and performance may vary over time. All operating parameters, including typical parameters, must be validated for each customer application by the customer's technical experts. Product specifications do not expand or otherwise modify Vishay's terms and conditions of purchase, including but not limited to the warranty expressed therein.

Hyperlinks included in this datasheet may direct users to third-party websites. These links are provided as a convenience and for informational purposes only. Inclusion of these hyperlinks does not constitute an endorsement or an approval by Vishay of any of the products, services or opinions of the corporation, organization or individual associated with the third-party website. Vishay disclaims any and all liability and bears no responsibility for the accuracy, legality or content of the third-party website or for that of subsequent links.

Vishay products are not designed for use in life-saving or life-sustaining applications or any application in which the failure of the Vishay product could result in personal injury or death unless specifically qualified in writing by Vishay. Customers using or selling Vishay products not expressly indicated for use in such applications do so at their own risk. Please contact authorized Vishay personnel to obtain written terms and conditions regarding products designed for such applications.

No license, express or implied, by estoppel or otherwise, to any intellectual property rights is granted by this document or by any conduct of Vishay. Product names and markings noted herein may be trademarks of their respective owners.