

# Proximity Sensor With Interrupt, VCSEL, and I<sup>2</sup>C Interface



## LINKS TO ADDITIONAL RESOURCES



## DESCRIPTION

VCNL36826M integrates a proximity sensor (PS), and a VCSEL into one small package. It incorporates photodiodes, amplifiers, and analog to digital converting circuits into a single chip by CMOS process. PS programmable interrupt features of individual high and low thresholds offers the best utilization of resource and power saving on the microcontroller.

## APPLICATIONS

- Handheld device
- Consumer device
- Industrial application

## FEATURES

- Package type: surface-mount
- Dimensions (L x W x H in mm): 2.55 x 2.05 x 1.0
- Integrated modules: vertical cavity surface emitting laser (VCSEL), proximity sensor (PS), and signal conditioning IC
- Interrupt function
- Smallest light hole opening design
- Supply voltage range  $V_{DD}$ : 2.74 V to 3.6 V
- Low power consumption I<sup>2</sup>C (SMBus compatible interface)
- Output type: I<sup>2</sup>C bus
- Temperature compensation: -40 °C to +85 °C
- Floor life: 168 h, MSL 3, according to J-STD-020
- Material categorization: for definitions of compliance please see [www.vishay.com/doc?99912](http://www.vishay.com/doc?99912)



## PROXIMITY FUNCTION

- Immunity to red glow (940 nm IRED)
- Programmable  $I_{VCSEL}$  sink current
- Intelligent cancellation to reduce cross talk phenomenon
- Smart persistence scheme to reduce PS response time
- Low power consumption mode
- Sunlight cancellation up to 100 klx

## INTERRUPT

- Programmable interrupt function for PS with upper and lower thresholds
- Adjustable persistence to prevent false triggers for PS

## PIN DEFINITION

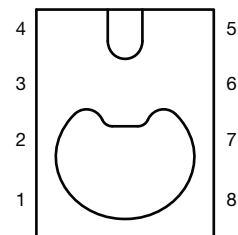

1	GND	5	$V_{DD}$
2	INT	6	$V_{DD}$
3	NC or GND	7	SDA
4	NC	8	SCL

## PRODUCT SUMMARY

PART NUMBER	OPERATING RANGE (mm)	OPERATING VOLTAGE RANGE (V)	I <sup>2</sup> C BUS VOLTAGE RANGE (V)	VCSEL DRIVING CURRENT (mA)	OUTPUT CODE	ADC RESOLUTION PROXIMITY / AMBIENT LIGHT
VCNL36826M	200	2.74 to 3.6	1.7 to 3.6	20	12 bit, I <sup>2</sup> C	12 bit / -



ORDERING INFORMATION			
ORDERING CODE	PACKAGING	VOLUME (1)	REMARKS
VCNL36826M	Tape and reel	MOQ: 3000 pcs, 3000 pcs/reel	2.55 mm x 2.05 mm x 1.0 mm

Note

(1) MOQ: minimum order quantity

ABSOLUTE MAXIMUM RATINGS (T <sub>amb</sub> = 25 °C, unless otherwise specified)					
PARAMETER	TEST CONDITION	SYMBOL	MIN.	MAX.	UNIT
Supply voltage		V <sub>DD</sub>	-0.3	3.8	V
Operation temperature range		T <sub>amb</sub>	-40	+85	°C
Storage temperature range		T <sub>stg</sub>	-40	+100	°C

BASIC CHARACTERISTICS (T <sub>amb</sub> = 25 °C, unless otherwise specified)						
PARAMETER	TEST CONDITION	SYMBOL	MIN.	TYP.	MAX.	UNIT
Supply voltage (2)		V <sub>DD</sub>	2.74	-	3.6	V
Supply current	Excluding VCSEL driving	I <sub>DD</sub>	100	200	300	μA
Shutdown current	Light condition = dark; V <sub>DD</sub> = 3.3 V, T <sub>amb</sub> = 25 °C	I <sub>DD</sub> (SD)	-	1	-	μA
PS dark (1)			-	-	2	step
I <sup>2</sup> C supply voltage		V <sub>PULL UP</sub>	1.65	-	-	V
I <sup>2</sup> C signal input, logic high	V <sub>DD</sub> = 3.3 V	V <sub>IH</sub>	1.26	-	-	V
I <sup>2</sup> C signal input, logic low	V <sub>DD</sub> = 3.3 V	V <sub>IL</sub>	-	-	0.73	V
Peak wavelength of VCSEL	I <sub>F</sub> = 10 mA	λ <sub>p(VCSEL)</sub>	-	940	-	nm
PS view angle (3)			-	60	-	°
VCSEL driving current			-	-	20	mA

Notes

(1) PS\_IT = 4T; I<sub>VCSEL</sub> = 20 mA; PS\_HG = 1

(2) Based on VCSEL current setting, V<sub>DD</sub> min. voltage need adjust, example as below

VCSEL current setting	8 mA	10 mA	12 mA	14 mA	16 mA	18 mA	20 mA
Min. V <sub>DD</sub>	2.74 V	2.84 V	2.94 V	3.03 V	3.11 V	3.19 V	3.29 V

(3) Shows total view angle of X axis (X axis: +10° to -50°; Y axis: ± 45°)

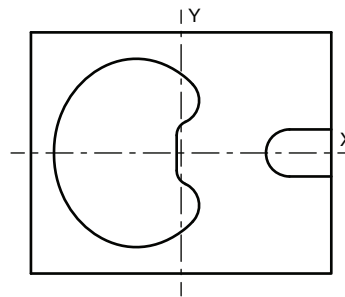



**LABEL FOR LASER CLASS 1**

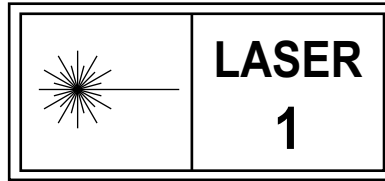

**Note**

- Product specification with IEC / EN 60825-1:2014 compliance and above label

**BLOCK DIAGRAM**

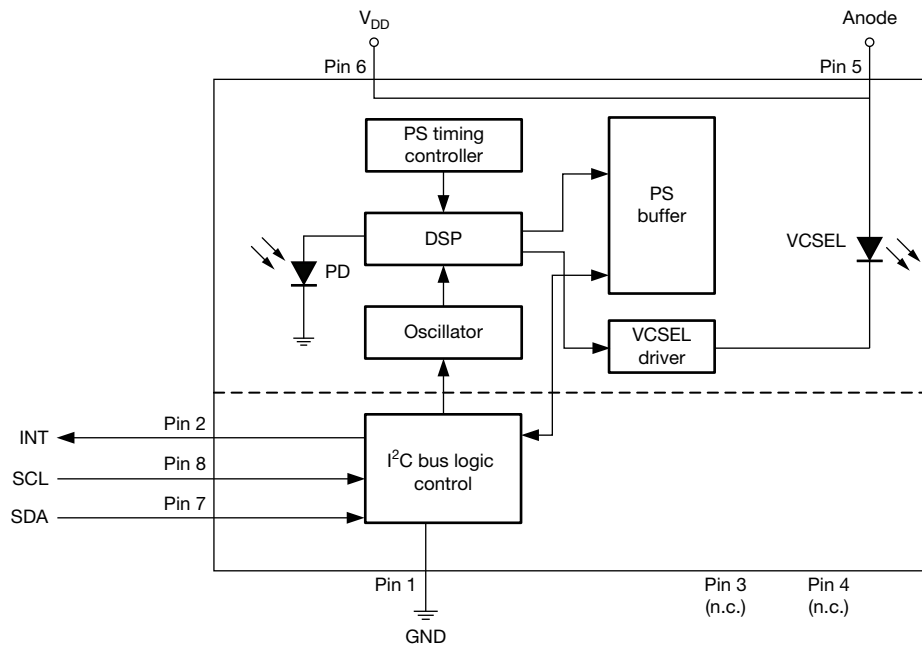



**PARAMETER TIMING INFORMATION**

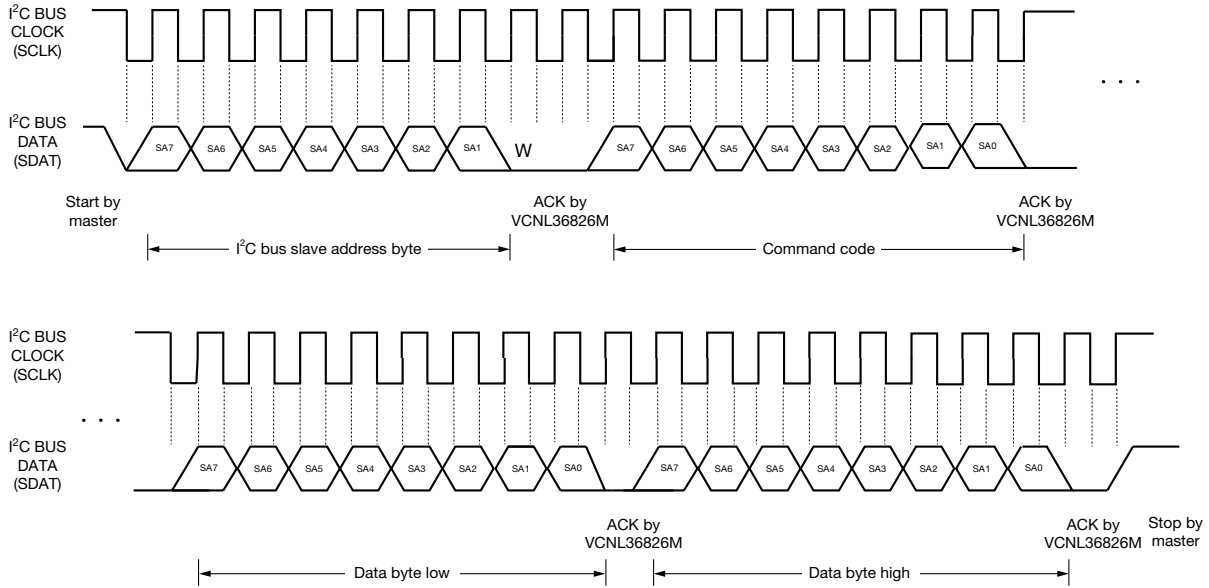

Fig. 2 - I<sup>2</sup>C Bus Timing for Sending Word Command Format

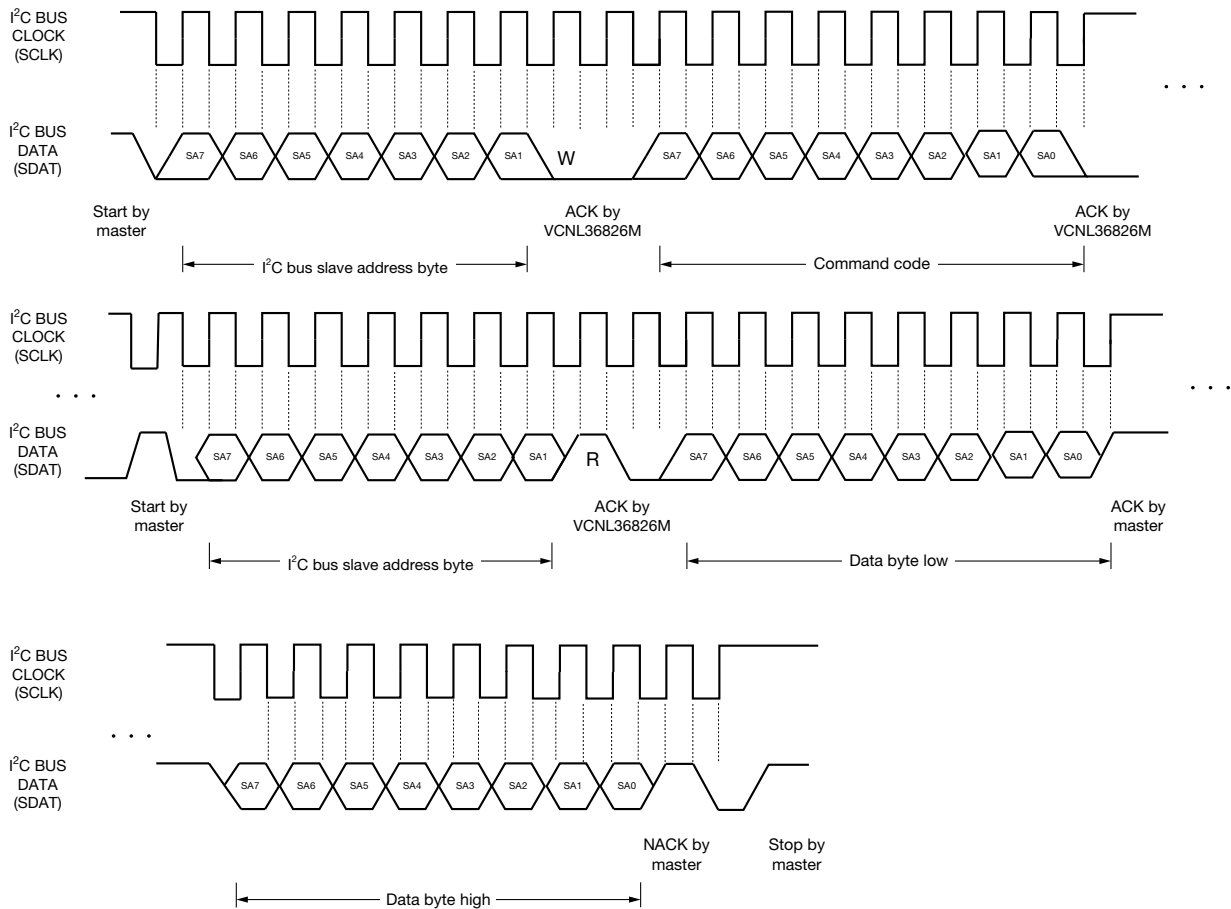

Fig. 3 - I<sup>2</sup>C Bus Timing for Receiving Word Command Format

**TYPICAL PERFORMANCE CHARACTERISTICS** ( $T_{amb} = 25\text{ }^{\circ}\text{C}$ , unless otherwise specified)

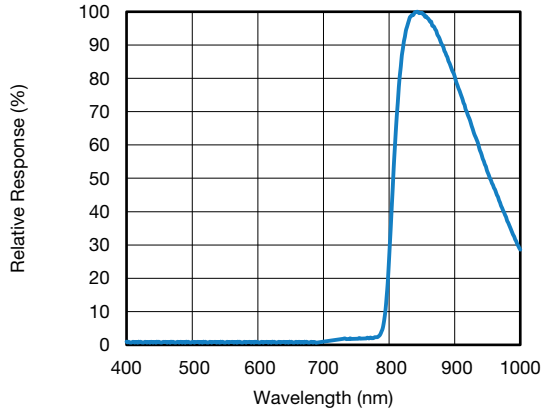

Fig. 4 - Normalized Spectral Response

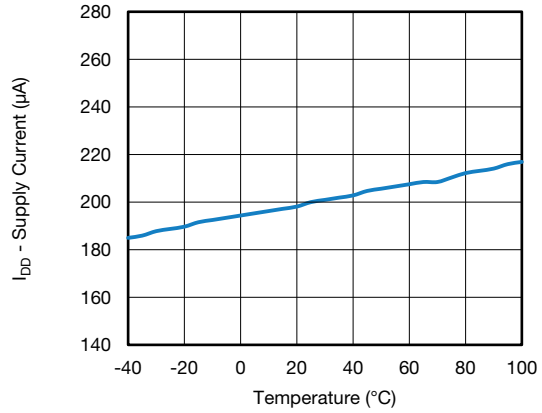

Fig. 7 -  $I_{DD}$  vs. Temperature

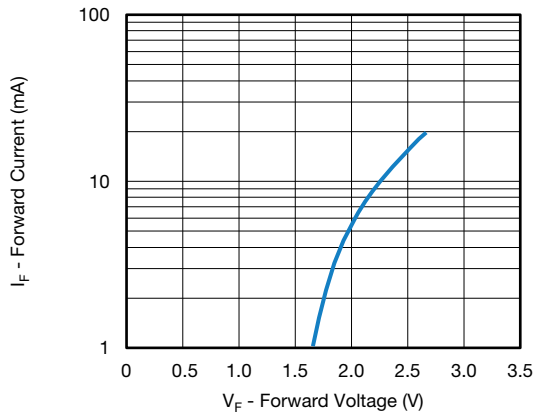

Fig. 5 - Forward Current vs. Forward Voltage

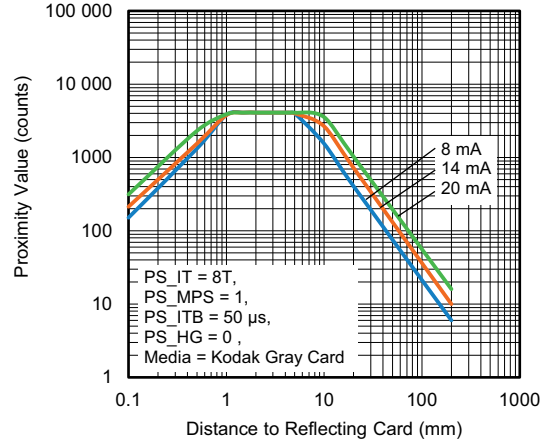

Fig. 8 - Proximity Value vs. Distance;  $PS_{IT} = 8T$

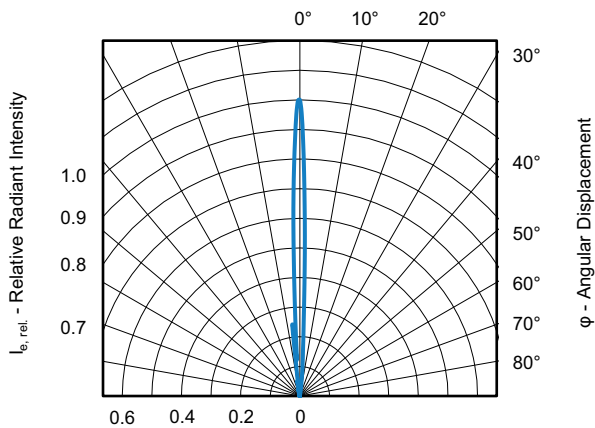

Fig. 6 - VCSEL Profile

For more information please study the application note “Designing the VCNL36826M Into an Application” ([www.vishay.com/doc?80569](http://www.vishay.com/doc?80569))

**APPLICATION INFORMATION**
**Pin Connection with the Host**

VCNL36826M integrates proximity sensor, and IR VCSEL all together with I<sup>2</sup>C interface. It is very easy for the baseband (CPU) to access PS output data via I<sup>2</sup>C interface without extra software algorithms. The hardware schematic is shown in the following diagram.

One additional 1 μF capacitor in the circuit is used for power supply noise rejection and 2.2 kΩ are proposed for the pull high resistor of I<sup>2</sup>C except 10 kΩ applied on INT pin.

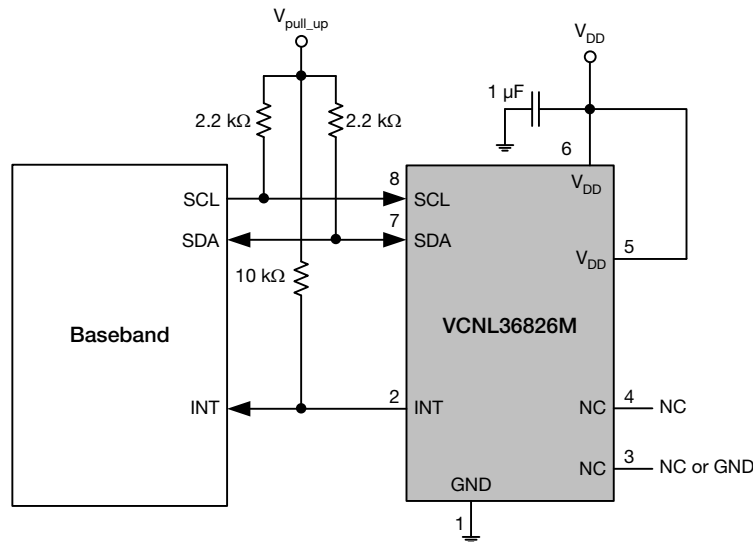
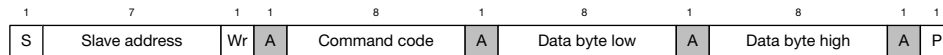

Fig. 9 - Hardware Pin Connection Diagram

**Digital Interface**

VCNL36826M applies single slave address 0x60 (HEX) of 7-bit addressing following I<sup>2</sup>C protocol. All operations can be controlled by the command register. The simple command structure helps users easily program the operation setting and latch the light data from VCNL36826M. As Fig. 9 shows, VCNL36826M's I<sup>2</sup>C command format is simple for read and write operations between VCNL36826M and the host. The white sections indicate host activity and the gray sections indicate VCNL36826M's acknowledgement of the host access activity. Write word and read word protocol is suitable for accessing registers particularly for 12-bit PS data. Interrupt can be cleared by reading data out from register: INT\_Flag. All command codes should follow read word and write word protocols.

Send word → write command to VCNL36826M



Receive word → read data from VCNL36826M

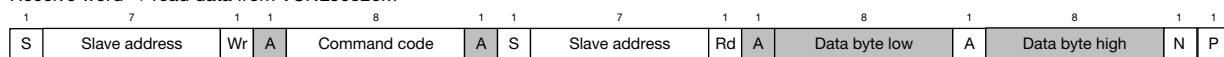

S = start condition  
 P = stop condition  
 A = acknowledge  
 N = not acknowledge  
 Host action  
 VCNL36826M response

Fig. 10 - Write Word and Read Word Protocol



Function Description

VCNL36826M supports different kinds of mechanical designs to achieve the best proximity detection performance for any color of object with more flexibility. The basic PS function settings, such as duty ratio, integration time, interrupt, and PS enable / disable and persistence, are handled by the register: PS\_CONF2\_L. Duty ratio controls the PS response time. Integration time represents the duration of the energy being received. The Interrupt is asserted when the PS detection levels over the high threshold level setting (register: PS\_THDH) or lower than low threshold (register: PS\_THDL). If the Interrupt function is enabled, the host reads the PS output data from VCNL36826M that saves host loading from periodically reading PS data. More than that, INT flag (register: INT\_Flag) indicates the behavior of INT triggered under different conditions. PS persistence (PS\_PERS) sets up the PS INT asserted conditions as long as the PS output value continually exceeds the threshold level. The intelligent cancellation level can be set on register: PS\_CANC to reduce the cross talk phenomenon.

A smart persistence (register: PS\_SMART\_PERS) is provided to get faster PS response time and prevent false trigger for PS.

TABLE 1 - COMMAND CODE AND REGISTER DESCRIPTION					
COMMAND CODE	DATE BYTE LOW / HIGH	REGISTER NAME	R / W	DEFAULT VALUE	FUNCTION DESCRIPTION
0x00	L	PS_CONF1_L	R / W	0x01	Standby and on / off
	H	PS_CONF1_H	R / W	0x00	Standby and on / off
0x03	L	PS_CONF2_L	R / W	0x01	PS period, persistence, interrupt, smart persistence and PS start / stop
	H	PS_CONF2_H	R / W	0x00	PS integration time, multi pulse and interrupt function
0x04	L	PS_CONF3_L	R / W	0x00	PS force mode and sunlight light protect interrupt setting
	H	PS_CONF3_H	R / W	0x00	PS VCSEL current
0x05	L	PS_THDL_L	R / W	0x00	PS low interrupt threshold setting
	H	PS_THDL_H	R / W	0x00	PS low interrupt threshold setting
0x06	L	PS_THDH_L	R / W	0x00	PS high interrupt threshold setting
	H	PS_THDH_H	R / W	0x00	PS high interrupt threshold setting
0x07	L	PS_CANC_L	R / W	0x00	PS cancellation LSB setting
	H	PS_CANC_H	R / W	0x00	PS cancellation MSB setting
0x08	L	PS_CONF4_L	R / W	0x00	PS auto-calibration period, number, interrupt setting
	H	PS_CONF4_H	R / W	0x00	PS low power mode setting
0xF8	L	PS_Data_L	R	0x00	PS channel LSB output data
	H	PS_Data_H	R	0x00	PS channel MSB output data
0xF9	L	Reserved	R	0x00	Reserved
	H	INT_Flag	R	0x00	PS interrupt flag
0xFA	L	ID_L	R	0x26	Device ID LSB
	H	ID_H	R	0x00	Device ID MSB
0xFB	L	PS_AC_Data_L	R	0x00	PS auto-calibration LSB data
	H	PS_AC_Data_H	R	0x00	PS auto-calibration MSB data, busy and sunlight protect

Note

- All of reserved register are used for internal test. Please keep as default setting

**Command Register Format**

VCNL36826M provides an 8-bit command register for PS controlling independently. The description of each command format is shown in the following tables.

**TABLE 2 - REGISTER: PS\_CONF1\_L DESCRIPTION**

REGISTER NAME		COMMAND CODE: 0x00_L (0x00 DATA BYTE LOW)
Command	Bit	Description
PS_CAL	7	Must be set to "1" when power on ready
Reserved	6 : 2	Default = (0 : 0 : 0 : 0 : 0)
PS_ON	1	Set this bit = "1" to enable bias circuit <b>Note</b> • Initialization process: step 1: set PS_ON = "1"; step 2: set PS_CAL = "1"
Reserved	0	Default = 1, must always stay = 1

**TABLE 3 - REGISTER: PS\_CONF1\_H DESCRIPTION**

REGISTER NAME		COMMAND CODE: 0x00_H (0x00 DATA BYTE HIGH)
Command	Bit	Description
Reserved	7 : 2	Default = (0 : 0 : 0 : 0 : 0)
Reserved	1	Must be set to "1" when power on ready
Reserved	0	Default = 0

**TABLE 4 - REGISTER: PS\_CONF2\_L DESCRIPTION**

REGISTER NAME		COMMAND CODE: 0x03_L (0x03 DATA BYTE LOW)
Command	Bit	Description
PS_Period	7 : 6	(0 : 0) = 10 ms, (0 : 1) = 20 ms, (1 : 0) = 40 ms, (1 : 1) = 80 ms PS sample period setting
PS_PERS	5 : 4	(0 : 0) = 1, (0 : 1) = 2, (1 : 0) = 3, (1 : 1) = 4 PS interrupt persistence setting
PS_INT	3 : 2	(0 : 0) = interrupt disable, (0 : 1) = logic high / low mode, (1 : 0) = first high, (1 : 1) = interrupt enable
PS_SMART_PERS	1	0 = disable PS smart persistence, 1 = enable PS smart persistence
PS_ST	0	0 = PS start, 1 = PS stop, default = 1; for active force mode set AF = 1 before setting PS_ST = 0

**TABLE 5 - REGISTER: PS\_CONF2\_H DESCRIPTION**

REGISTER NAME		COMMAND CODE: 0x03_H (0x03 DATA BYTE HIGH)
Command	Bit	Description
PS_IT	7 : 6	(0 : 0) = 1T, (0 : 1) = 2T, (1 : 0) = 4T, (1 : 1) = 8T
PS_MPS	5 : 4	(0 : 0) = 1, (0 : 1) = 2, (1 : 0) = 4, (1 : 1) = 8; PS multi-pulse setting
PS_ITB	3	0: ITB = 25 μs, 1: ITB = 50 μs
PS_HG	2	0 = disable, 1 = enable, PS high gain mode
Reserved	1 : 0	Default = (0 : 0)

**TABLE 6 - REGISTER: PS\_CONF3\_L DESCRIPTION**

COMMAND CODE: 0x04_L (0x04 DATA BYTE LOW)		
Register	Bit	Description
Reserved	7	0
PS_AF	6	0 = auto mode; 1 = force mode
PS_FOR_Trig	5	0 = no PS active force mode trigger, 1 = trigger one time cycle VCNL36826M output one cycle data every time host writes in "1" to sensor. The state returns to "0" automatically
PS_FORCENUM	4	0 = one detect cycle after trigger, 1 = two detect cycle after trigger
Reserved	3	When use PS function, must write "1"
PS_SP_INT	2	0 = disable, 1 = enable, PS sunlight light protect INT setting
Reserved	1 : 0	Reserved

**TABLE 7 - REGISTER: PS\_CONF3\_H DESCRIPTION**

COMMAND CODE: 0x04_H (0x04 DATA BYTE HIGH)		
Register	Bit	Description
PS_SC	7 : 5	Default = (0 : 0 : 0), with all 3 bit = "1", (1 : 1 : 1), sunlight cancellation is enabled
PS_HD	4	0 = PS output is 12 bits, 1 = PS output is 16 bits
Reserved	3	Default = 0
I_VCSEL	2 : 0	(0 : 0 : 0) = reserved, (0 : 0 : 1) = 8 mA, (0 : 1 : 0) = 10 mA, (0 : 1 : 1) = 12 mA, (1 : 0 : 0) = 14 mA, (1 : 0 : 1) = 16 mA, (1 : 1 : 0) = 18 mA, (1 : 1 : 1) = 20 mA; VCSEL current selection setting

**TABLE 8 - REGISTER: PS\_THDL DESCRIPTION**

COMMAND CODE: 0x05_L (0x05 DATA BYTE LOW) AND 0x05_H (0x05 DATA BYTE HIGH)		
Command	Bit	Description
PS_THDL_L	7 : 0	0x00 to 0xFF, PS interrupt low threshold setting LSB
PS_THDL_H	3 : 0	0x00 to 0x0F, PS interrupt low threshold setting MSB

**TABLE 9 - REGISTER: PS\_THDH DESCRIPTION**

COMMAND CODE: 0x06_L (0x06 DATA BYTE LOW) AND 0x06_H (0x06 DATA BYTE HIGH)		
Command	Bit	Description
PS_THDH_L	7 : 0	00H to FFH, PS interrupt high threshold setting LSB
PS_THDH_H	3 : 0	00H to 0FH, PS interrupt high threshold setting MSB

**TABLE 10 - REGISTER: PS\_CANC DESCRIPTION**

COMMAND CODE: 0x07_L (0x07 DATA BYTE LOW) AND 0x07_H (0x07 DATA BYTE HIGH)		
Command	Bit	Description
PS_CANC_L	7 : 0	0x00 to 0xFF, PS cancellation level setting LSB
PS_CANC_H	3 : 0	0x00 to 0x0F, PS cancellation level setting MSB

**TABLE 11 - REGISTER: PS\_CONF4\_L DESCRIPTION**

COMMAND CODE: 0x08_L (0x08 DATA BYTE LOW)		
Register	Bit	Description
PS_AC_PERIOD	7 : 6	(0 : 0) = 3 ms, (0 : 1) = 6 ms, (1 : 0) = 12 ms, (1 : 1) = 24 ms; PS auto-calibration detect sample period setting
PS_AC_NUM	5 : 4	(0 : 0) = 1, (0 : 1) = 2, (1 : 0) = 4, (1 : 1) = 8; PS auto-calibration detect sample number setting
PS_AC	3	0 = disable, 1 = enable; PS auto-calibration enable; need set PS_AF = 1
PS_AC_TRIG	2	0 = disable, 1 = enable; trigger one time auto-calibration
Reserved	1	Reserved
PS_AC_INT	0	0 = disable, 1 = enable; PS auto-calibration INT setting

**TABLE 12 - REGISTER: PS\_CONF4\_H DESCRIPTION**

COMMAND CODE: 0x08_H (0x08 DATA BYTE HIGH)		
Register	Bit	Description
Reserved	7 : 3	Default = (0 : 0 : 0 : 0 : 0)
PS_LPPER	2 : 1	(0 : 0) = 40 ms, (0 : 1) = 80 ms, (1 : 0) = 160 ms, (1 : 1) = 320 ms; PS detection period setting at low power mode (PS_LPEN = 1)
PS_LPEN	0	0 = disable, 1 = enable = starts proximity low power measurements; now PS_LPPER used as period, but I_VCSEL, PS_IT, PS_ITB, PS_MPS as defined within register 3 and register 4

**TABLE 13 - READ OUT REGISTER DESCRIPTION**

Register	Command Code	Bit	Description
PS_Data_L	0xF8_L (0xF8 data byte low)	7 : 0	0x00 to 0xFF, PS output data
PS_Data_H	0xF8_H (0xF8 data byte high)	3 : 0	0x00 to 0x0F, PS output data
INT_Flag	0xF9_H (0xF9 data byte high)	7 : 6 5 4 3 2 1 0	Reserved PS_ACFLAG, after PS finishing auto-calibration, INT raise PS_SPFLAG, PS entering protection mode Reserved Reserved PS_IF_CLOSE, PS rises above PS_THDH INT trigger event PS_IF_AWAY, PS drops below PS_THDL INT trigger event
ID_L	FAH_L (FAH data byte low)	7 : 0	Default = 0010 0110, device ID LSB byte
ID_H	FAH_H (FAH data byte high)	7 : 6 5 : 4 3 : 0	(0 : 0) (0 : 0) slave address = 0x60 Version code (0 : 0 : 0 : 0) device ID MSB byte
PS_AC_Data_L	0xFB_L (0xFB data byte low)	7 : 0	0x00 to 0xFF, PS auto-calibration data (LSB)
PS_AC_Data_H	0xFB_H (0xFB data byte high)	7 6 5 : 4 3 : 0	AC_BUSY, when AC, the bit will be "1" AC_SUN, PS enters sunlight protect during auto-calibration Reserved 0x00 to 0xFF, PS auto-calibration data (MSB)

### Initialization

VCNL36826M includes default values for each register. As long as power is on, it is ready to be controlled by host via I<sup>2</sup>C bus.

### Proximity Interrupt

There are three different Interrupt methods: "normal" interrupt mode, first high mode and so-called "logic high / low" mode.

The first high mode is selected by setting (0x03\_L, bit 3:2 = 1:0) within register PS\_CONF2\_L. In this mode, the initial interrupt that is triggered needs to be with regard to the high threshold (PS\_THDH). Passing underneath the low threshold will have no effect until the first high threshold event has occurred. In this mode, the interrupt event will remain set, until it is cleared, by reading the interrupt register.

The "normal" interrupt mode is selected with PS\_INT = interrupt enabled (0x03\_L, bit 3 : 2 = 1 : 1) within register PS\_CONF2\_L. Tests with ready-made application will show where to set the value for high threshold (PS\_THDH) and low threshold (PS\_THDL). For more information and explanation please study also the application note [www.vishay.com/doc?80569](http://www.vishay.com/doc?80569).

The "logic high / low" mode is selected with PS\_INT = trigger by logic high/low mode (0x03\_L, bit 3 : 2 = 0 : 1) within register PS\_CONF2\_L. When this mode is selected, the interrupt pin is pulled low when the proximity counts reach the programmed high threshold (PS\_THDH) and will return to high level when counts drop below the count value for low threshold (PS\_THDL).

With help of the function PS persistence one may also improve a reliable detection that not just one short event directly triggers an interrupt, but only when 2 (or up to 4) consecutive proximity measurements are above the programmed threshold value the interrupt will be set; please see also within the application note [www.vishay.com/doc?80569](http://www.vishay.com/doc?80569).

### PROXIMITY LOW POWER CONSUMPTION MODE

With register PS\_LPEN set to 1, proximity sensor operates in a special low power consumption mode offering significant lower power consumption of just 17.75  $\mu\text{A}$  with response time of 320 ms for proximity detection. This is a remarkable feature for any application requiring lower power consumption and did not want to always request one proximity measurement with proximity force mode (PS\_AF and PS\_TRIG).

PS period (ms)	10	20	40	80	160	320
Normal mode ( $\mu\text{A}$ )	600.00	400.00	300.00	250.00	n/a	n/a
Low power mode ( $\mu\text{A}$ )	n/a	n/a	107.00	56.00	30.50	17.75

#### Note

- $I_{\text{VCSEL}} = 10 \text{ mA}$ ;  $\text{PS\_IT} = 8\text{T}$

### PROXIMITY DETECTION HYSTERESIS

A PS detection hysteresis is important that keeps PS state in a certain range of detection distance. For example, PS INT asserts when PS value over PS\_THDH. Host switches off panel backlight and then clears INT. When PS value is less than PS\_THDL, Host switches on panel backlight. Any PS value lower than PS\_THDH or higher than PS\_THDL, PS INT will not be asserted. Host does keep the same state.

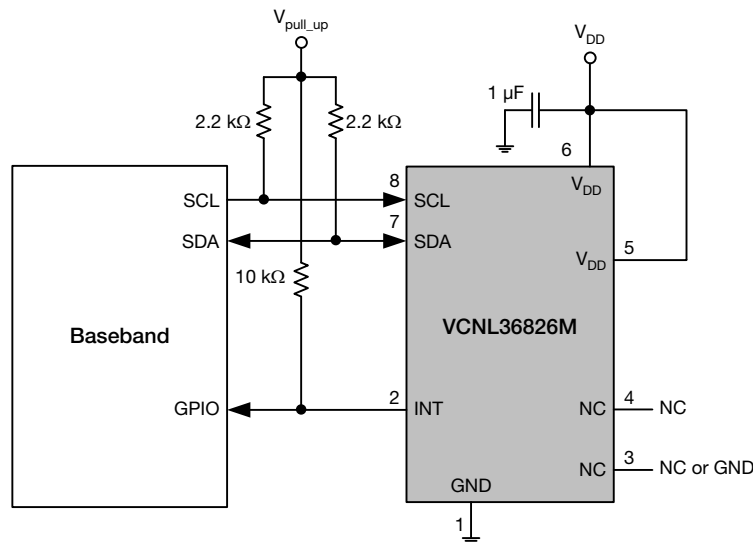

Fig. 11 - VCNL36826M Reference Circuit Connection With Host (proximity detection logic output mode)  
(VCNL36826M INT pin connecting to BB GPIO instead of INT pin)

**PACKAGE INFORMATION** in millimeters

Fig. 12 - VCNL36826M Package Dimensions

**LAYOUT PAD INFORMATION** in millimeters

Fig. 13 - VCNL36826M PCB Layout Footprint

<b>RECOMMENDED STORAGE AND REBAKING CONDITIONS</b>				
PARAMETER	CONDITIONS	MIN.	MAX.	UNIT
Storage temperature		-40	85	°C
Relative humidity		-	60	%
Open time		-	168	h
Total time	From the date code on the aluminized envelope (unopened)	-	12	months
Rebaking	Tape and reel: 60 °C	-	22	h
	Tube: 60 °C	-	22	h

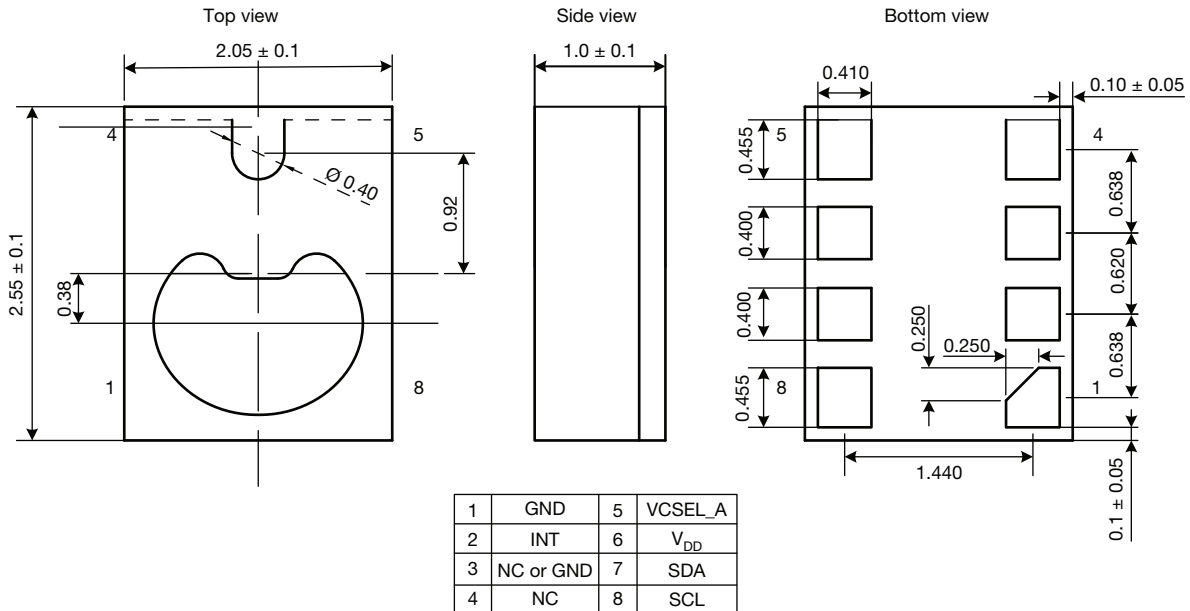
**RECOMMENDED INFRARED REFLOW**

Soldering conditions which are based on J-STD-020 C

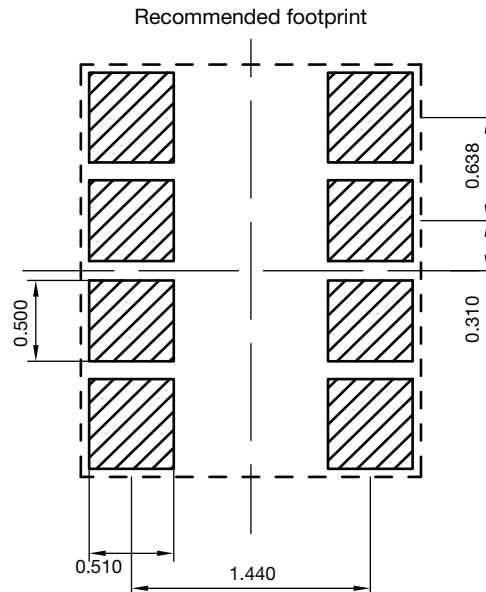
IR REFLOW PROFILE CONDITION			
PARAMETER	CONDITIONS	TEMPERATURE	TIME
Peak temperature		260 °C + 5 °C / - 5 °C (max.: 265 °C)	10 s
Preheat temperature range and timing		150 °C to 200 °C	60 s to 180 s
Timing within 5 °C to peak temperature		-	10 s to 30 s
Timing maintained above temperature / time		217 °C	60 s to 150 s
Timing from 25 °C to peak temperature		-	8 min (max.)
Ramp-up rate		3 °C/s (max.)	-
Ramp-down rate		6 °C/s (max.)	-

Recommend Normal Solder Reflow is 235 °C to 265 °C

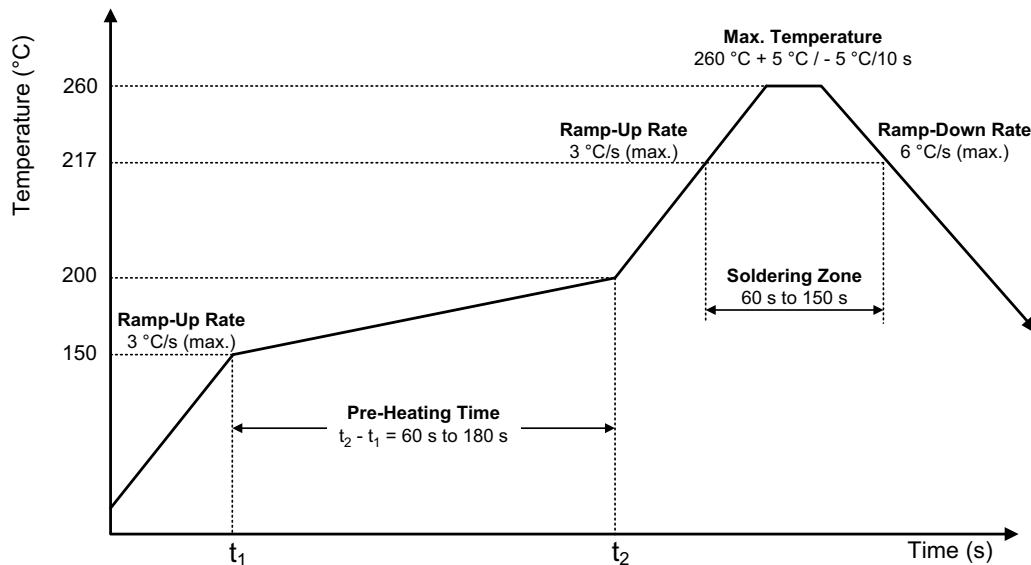

Fig. 14 - VCNL36826M Solder Reflow Profile Chart

**RECOMMENDED IRON TIP SOLDERING CONDITION AND WARNING HANDLING**

1. Solder the device with the following conditions:
  - 1.1. Soldering temperature: 400 °C (max.)
  - 1.2. Soldering time: 3 s (max.)
2. If the temperature of the method portion rises in addition to the residual stress between the leads, the possibility that an open or short circuit occurs due to the deformation or destruction of the resin increases
3. The following methods: VPS and wave soldering, have not been suggested for the component assembly
4. Cleaning method conditions:
  - 4.1. Solvent: methyl alcohol, ethyl alcohol, isopropyl alcohol
  - 4.2. Solvent temperature < 45 °C (max.)
  - 4.3. Time: 3 min (min.)



TAPE PACKAGING INFORMATION in millimeters

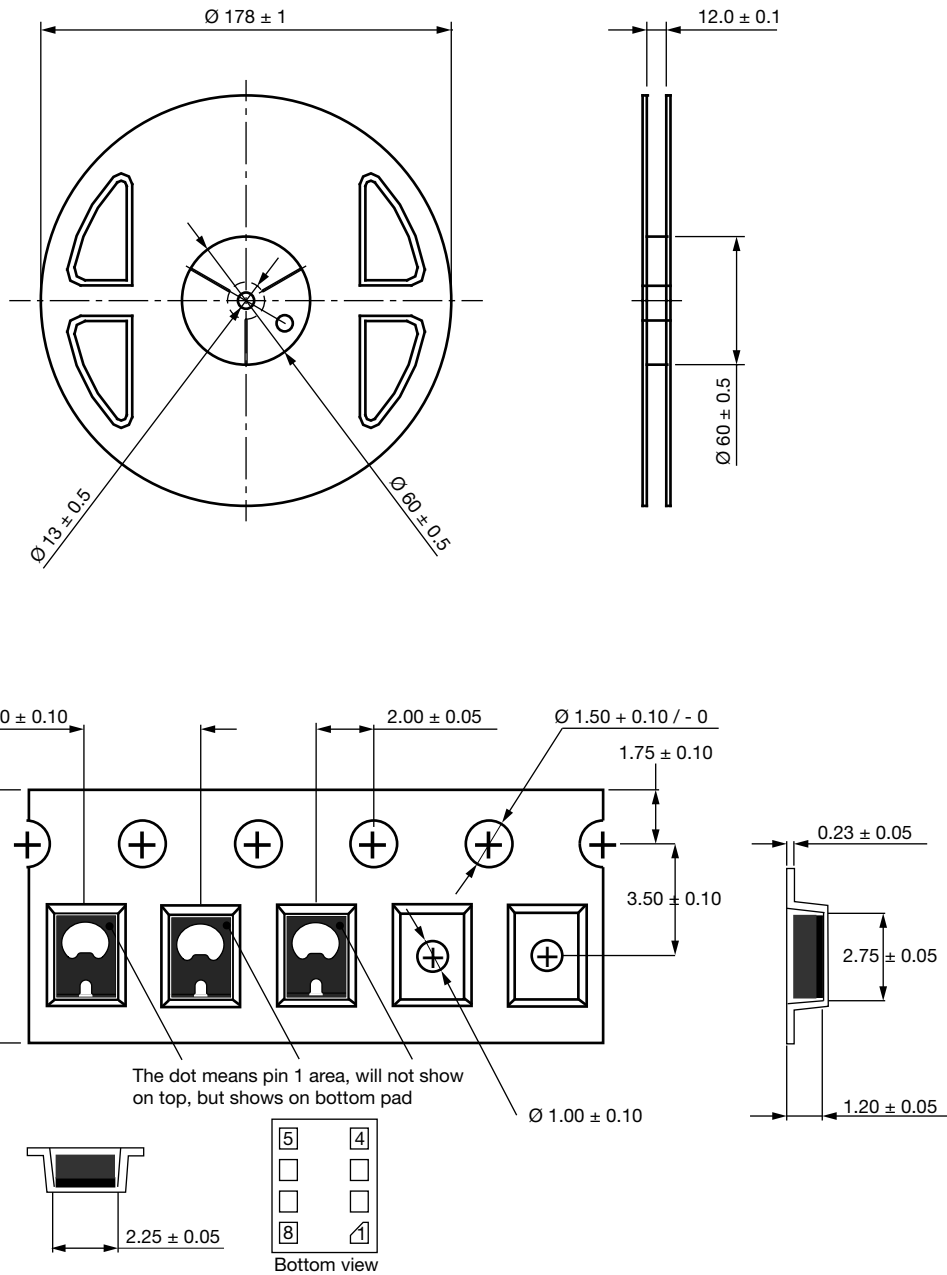



## **Disclaimer**

ALL PRODUCT, PRODUCT SPECIFICATIONS AND DATA ARE SUBJECT TO CHANGE WITHOUT NOTICE TO IMPROVE RELIABILITY, FUNCTION OR DESIGN OR OTHERWISE.

Vishay Intertechnology, Inc., its affiliates, agents, and employees, and all persons acting on its or their behalf (collectively, "Vishay"), disclaim any and all liability for any errors, inaccuracies or incompleteness contained in any datasheet or in any other disclosure relating to any product.

Vishay makes no warranty, representation or guarantee regarding the suitability of the products for any particular purpose or the continuing production of any product. To the maximum extent permitted by applicable law, Vishay disclaims (i) any and all liability arising out of the application or use of any product, (ii) any and all liability, including without limitation special, consequential or incidental damages, and (iii) any and all implied warranties, including warranties of fitness for particular purpose, non-infringement and merchantability.

Statements regarding the suitability of products for certain types of applications are based on Vishay's knowledge of typical requirements that are often placed on Vishay products in generic applications. Such statements are not binding statements about the suitability of products for a particular application. It is the customer's responsibility to validate that a particular product with the properties described in the product specification is suitable for use in a particular application. Parameters provided in datasheets and / or specifications may vary in different applications and performance may vary over time. All operating parameters, including typical parameters, must be validated for each customer application by the customer's technical experts. Product specifications do not expand or otherwise modify Vishay's terms and conditions of purchase, including but not limited to the warranty expressed therein.

Hyperlinks included in this datasheet may direct users to third-party websites. These links are provided as a convenience and for informational purposes only. Inclusion of these hyperlinks does not constitute an endorsement or an approval by Vishay of any of the products, services or opinions of the corporation, organization or individual associated with the third-party website. Vishay disclaims any and all liability and bears no responsibility for the accuracy, legality or content of the third-party website or for that of subsequent links.

Vishay products are not designed for use in life-saving or life-sustaining applications or any application in which the failure of the Vishay product could result in personal injury or death unless specifically qualified in writing by Vishay. Customers using or selling Vishay products not expressly indicated for use in such applications do so at their own risk. Please contact authorized Vishay personnel to obtain written terms and conditions regarding products designed for such applications.

No license, express or implied, by estoppel or otherwise, to any intellectual property rights is granted by this document or by any conduct of Vishay. Product names and markings noted herein may be trademarks of their respective owners.