



Sensor Board Guide for the VCNL36828P

INTRODUCTION

The VCNL36828P sensor board is intended to be used in conjunction with Vishay’s SensorXplorer demonstration kit, or as a standalone unit, to evaluate the capabilities of the VCNL36828P proximity sensor.

SensorXplorer™

The SensorXplorer (Fig. 1) is a demonstration kit designed to help evaluate Vishay’s digital sensors featured on Vishay’s sensor boards. These boards, along with their respective software modules, can be used to demonstrate and test each sensor’s functionalities, allowing the user to quickly understand how various settings affect the sensor’s results. The SensorXplorer board includes an USB to I²C interface chip, a 3.3 V regulator, several indicator LEDs, as well as multiple GPIOs to control the functionality of each board and allow data to be read and displayed on a PC. To get an overview of available sensor boards, as well as to download the software modules and board design files, please visit: www.vishay.com/optoelectronics/SensorXplorer. Here you will also find a link next to each board showing its availability at each of our distributors.

Complete information about the SensorXplorer kit as well as all available sensor boards is available at www.vishay.com/optoelectronics/SensorXplorer. The same page also allows you to check inventory of SensorXplorer kits and Vishay sensor boards at our distributors.

The SensorXplorer installation guide is available for download from the following link: www.vishay.com/doc?849222

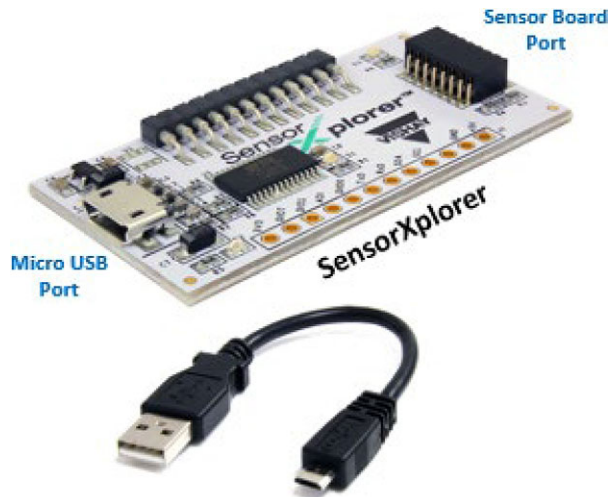

Fig. 1 - SensorXplorer

USING THE SENSOR BOARD WITH THE SensorXplorer

Following the instructions in the SensorXplorer installation guide, install the SensorXplorer software on your PC, then connect the SensorXplorer evaluation board to your PC and the Vishay sensor board.

The respective demo board software module can then be downloaded from: www.vishay.com/landingpage/SensorXplorer/

Once the module is unzipped the software can be run without the need for further installation.

You are now ready to explore the sensor and its different settings to see how they will work in your application.



HOW TO USE THE DEMOSOFTWARE

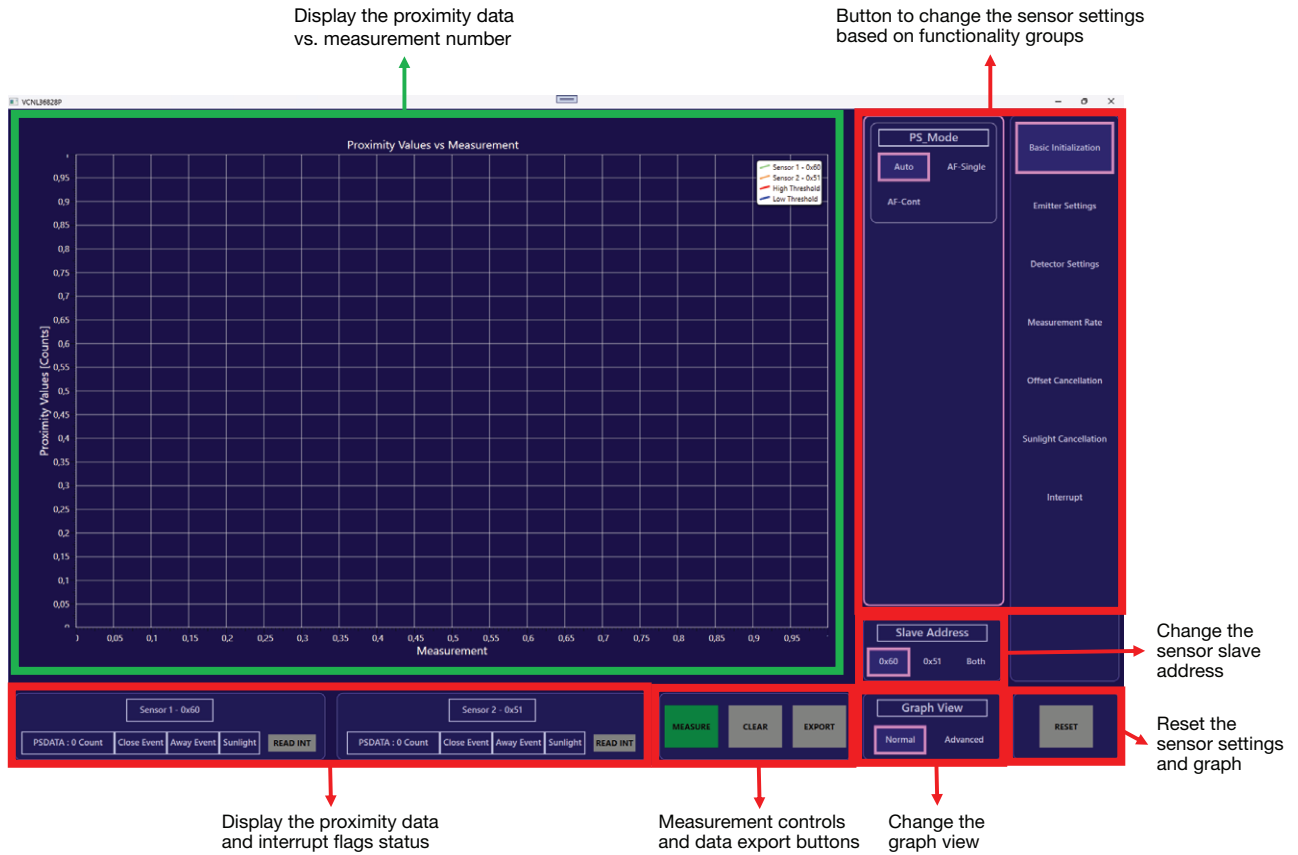

Fig. 2 - Demosoftware GUI

USING THE SENSOR BOARD FOR ITSELF

If you want to use the sensor board within your own application and with your own I²C master, simply connect the board to the power supply (1.8 V, 3.3 V, GND) and the I²C lines (SDA, SCL) test pins as shown in Fig. 3.

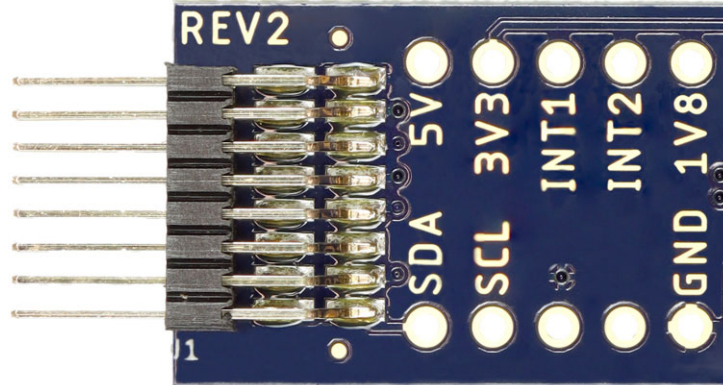

Fig. 3 - Connection of the Sensor Board (power supply and I²C lines)

SCHEMATIC OF THE VCNL36828P SENSOR BOARD

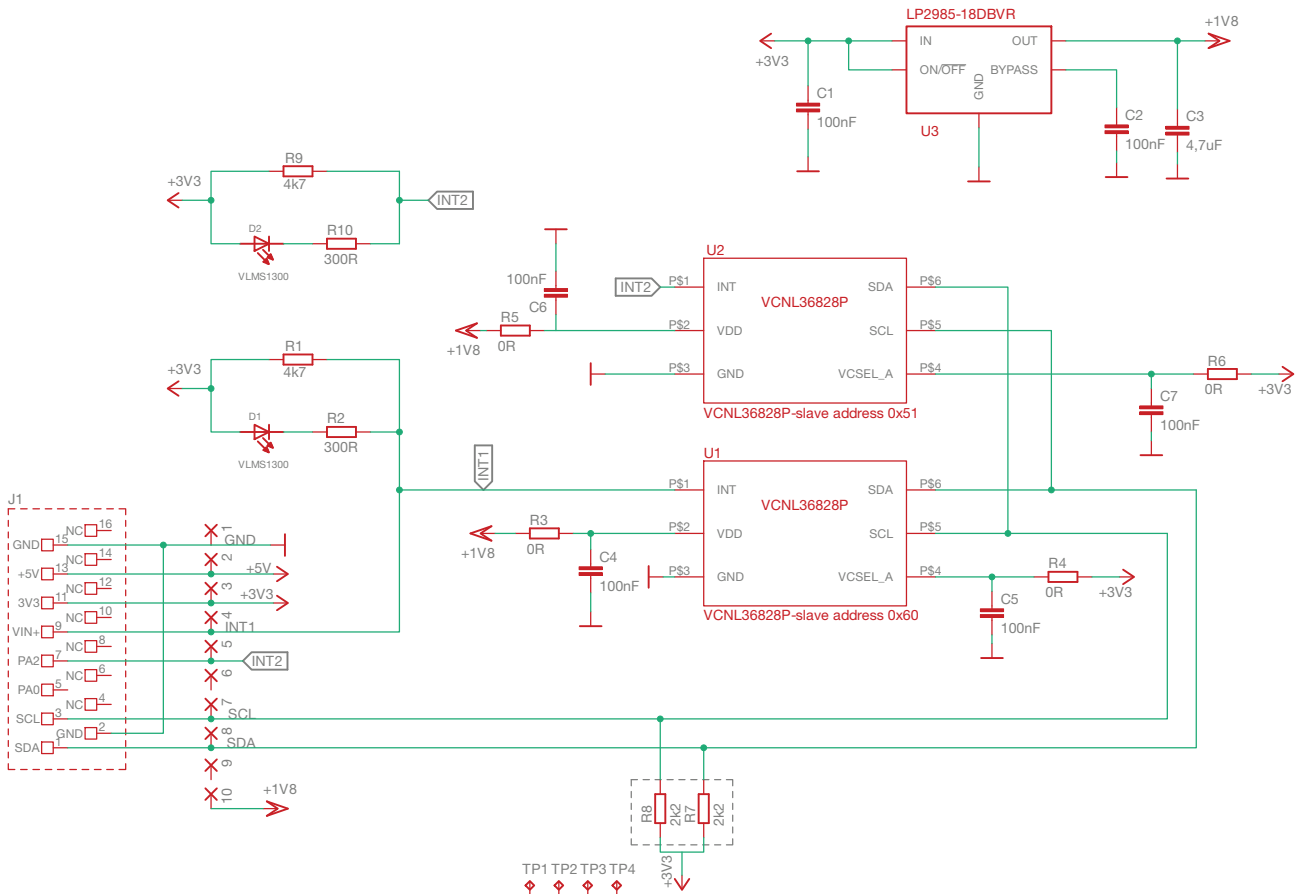
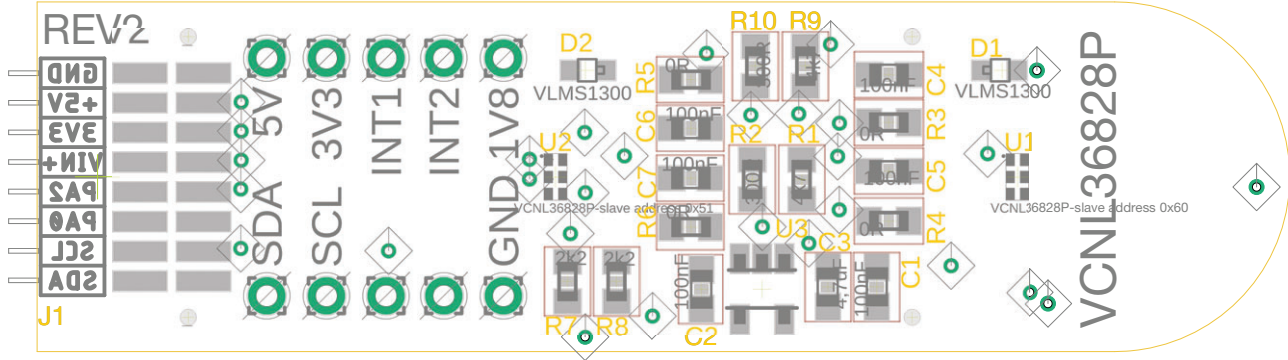

Fig. 4 - Schematic of the VCNL36828P Sensor Board

ASSEMBLY OF THE VCNL36828P SENSOR BOARD

VCNL36828P sensor board, rev. 2.0



Assembly top

BILL OF MATERIALS					
ITEM	QUANTITY	REFERENCE	PART	VALUE	PACKAGE
1	6	C1, C2, C4, C5, C6, C7	Capacitor	100 nF	0603
2	1	C3	Capacitor	4.7 μ F	0603
3	2	R1, R9	Resistor	4.7 k Ω	0603
4	2	R7, R8	Resistor	2.2 k Ω	0603
5	2	R2, R10	Resistor	300 Ω	0603
6	4	R3, R4, R5, R6	Resistor	0 Ω	0603
7	2	D1, D2	LED	VLMS1300	SMD
8	2	U1, U2	Sensor	VCNL36828P	SMD
9	1	U3	LD0	LP2985-18DBVR	SOT-23/5
10	1	J1	Edge Connector	2 x 8 pos.	SMD