

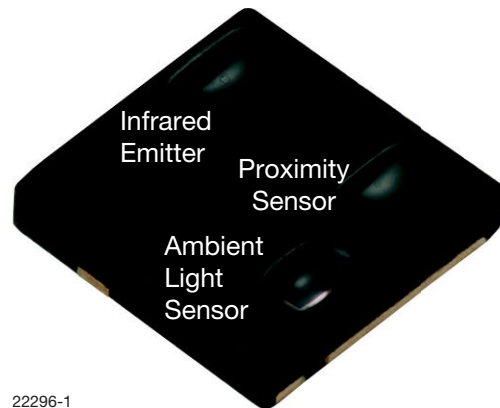

# Designing VCNL4000 into an Application

## INTRODUCTION

The VCNL4000 is a proximity sensor with an integrated ambient light sensor. It is the industry's first optical sensor to combine an infrared emitter, PIN photodiode, ambient light sensor and signal processing in a single package with a 16-bit ADC for proximity measurement as well as ambient light measurement. The device provides ambient light sensing to support conventional backlight and display brightness adjustment, and proximity sensing for object and motion detection. With a range of up to 20 cm (7.9"), this stand-alone, single component greatly simplifies the use and design-in of a proximity sensor in consumer and industrial applications. The VCNL4000 features a miniature leadless package (LLP) for surface mounting in a 3.95 mm x 3.95 mm package with a low profile of 0.75 mm designed specifically for the low height requirements of smart phone, mobile phone, digital camera, and tablet PC applications. Through its standard I<sup>2</sup>C bus serial digital interface, it allows easy access to a "Proximity Signal" and "Light intensity" measurement without complex calculations or programming.



22296-1

Fig. 1 - VCNL4000 Top View

## COMPONENTS (BLOCK DIAGRAM)

The major components of the VCNL4000 are shown in the block diagram.

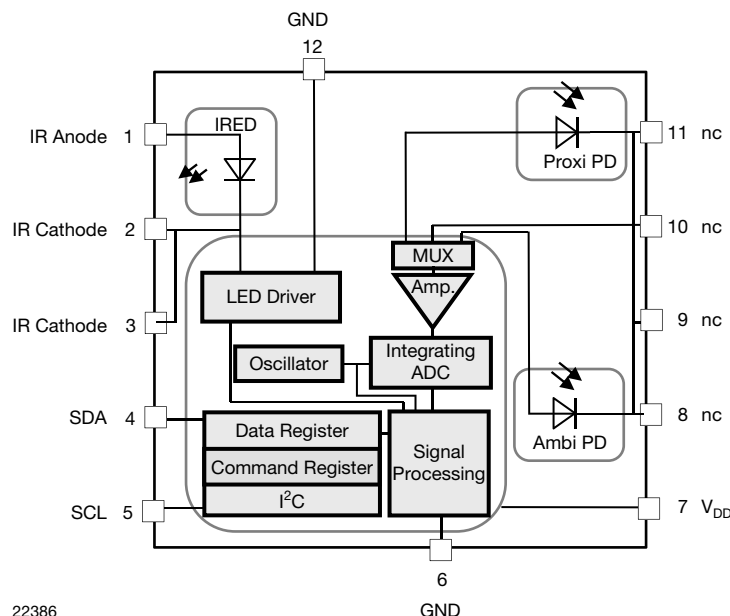

22386

Fig. 2 - VCNL4000 Detailed Block Diagram

## Designing VCNL4000 into an Application

The integrated **infrared emitter** has a peak wavelength of 890 nm. It emits light that reflects off an object within 20 cm of the sensor. The infrared emitter spectrum is shown as a solid line in. The infrared emitter has a programmable drive current from 10 mA to 200 mA in 10 mA steps. The infrared light emitted is modulated at one of four user defined carrier frequencies: 390.625 kHz, 781.25 kHz, 1.5625 MHz, or 3.125 MHz.

The **PIN photodiode** receives the light that is reflected off the object and converts it to a current. It has a peak sensitivity of 890 nm, matching the peak wavelength of the emitter. It is insensitive to ambient light. It ignores the DC component of light and “looks for” the pulsed light at one of the four frequencies used by the emitter. **Using a modulated signal for proximity provides distinct advantages over other sensors on the market.**

The **ambient light sensor** receives the visible light and converts it to a current. The human eye can see light of wavelengths from 400 nm to 700 nm with a peak of 560 nm. Vishay’s ambient light sensor closely matches this range of sensitivity. It has peak sensitivity at 540 nm and a bandwidth from 430 nm to 610 nm.

The application specific integrated circuit or **ASIC** includes an LED driver, I<sup>2</sup>C bus interface, amplifier, integrating analog to digital converter, oscillator, and Vishay’s “secret sauce” signal processor. For proximity, it converts the current from the PIN photodiode to a 16-bit digital data output value. For ambient light sensing, it converts the current from the ambient light detector, amplifies it and converts it to a 16-bit digital output stream.

### PIN CONNECTIONS

Figure 4 shows the pin assignments of the VCNL4000. Only six of these pins need to be electrically connected while the remainder should be solder pad connections. The six connections include:

- Pin 1 - IR anode to the power supply
- Pin 4 - SDA to microcontroller
- Pin 5 - SCL to microcontroller
- Pin 7 - V<sub>DD</sub> to the power supply
- Pin 6, pin 12 - connect to ground
- Pin 2, pin 3 - IR cathode, no connect
- Pins 8 thru 11 - **must not** be connected

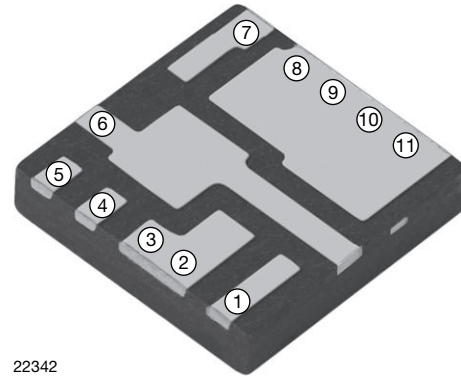

22342

Fig. 3 - VCNL4000 Bottom View

The power supply for the ASIC (V<sub>DD</sub>) and infrared emitter has a defined range from 2.5 V to 3.6 V. It is best if V<sub>DD</sub> is connected to a regulated power supply and pin 1, IR\_Anode, is connected directly to the battery. This eliminates any influence of the high infrared emitter current pulses on the V<sub>DD</sub> supply line. The ground pins 6 and 12 are electrically the same. They both use the bottom metal case and may be routed to the same stable ground plane. The power supply decoupling components shown in fig. 4 are strongly recommended to isolate the sensor from other possible noise on the same power rail. The 100 nF capacitor should be placed close to the V<sub>DD</sub> pin. The SCL and SDA lines need a pull-up resistor. The resistor values depend on the application and on the I<sup>2</sup>C bus speed.

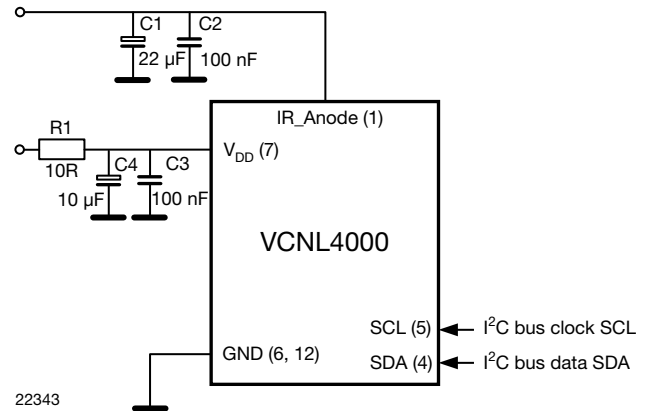

22343

Fig. 4 - VCNL4000 Application Circuit

APPLICATION NOTE

## Designing VCNL4000 into an Application

### MECHANICAL DESIGN CONSIDERATIONS

The VCNL4000 is a fully integrated proximity and ambient light sensor. Competing sensors use a discrete infrared emitter which leads to complex geometrical calculations to determine the position of the emitter. Competing sensors also require a mechanical barrier between the emitter and detectors to eliminate crosstalk; light reflecting off the inside of the window cover which can produce false proximity readings. **The VCNL4000 does not require a mechanical barrier.** The signal processor continuously compensates for the light reflected from windows ensuring a proper proximity reading. As a fully integrated sensor, the design process is greatly simplified.

The only dimensions that the design engineer needs to consider are the distance from the top surface of the sensor to the outside surface of the window and the size of the window. These dimensions will determine the size of the detection zone.

The angle of half intensity of the emitter and the angle of half sensitivity of the PIN photodiode are  $\pm 55^\circ$  as shown in fig. 5 and fig. 6.

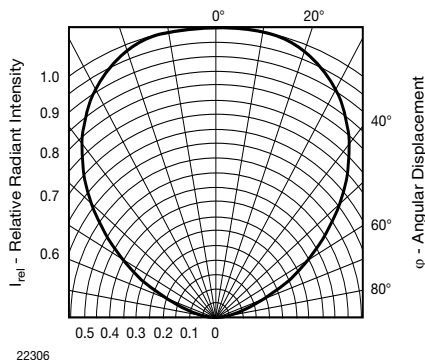

Fig. 5 - Angle of Half Intensity of the Emitter

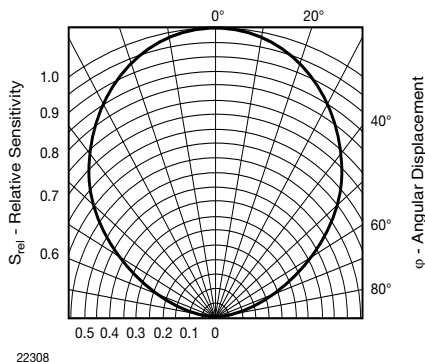

Fig. 6 - Angle of Half Sensitivity of the PIN Photodiode

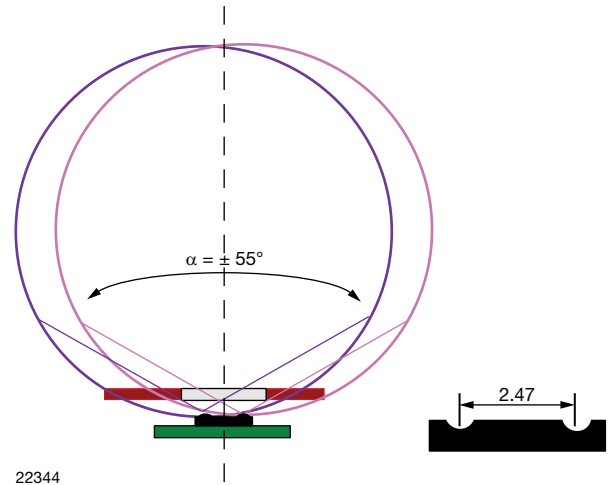

Fig. 7 - Emitter and Detector Angle and Distance

First, the center of the sensor and center of the window should be aligned. With the assumption that the detection zone is a cone shaped region with an angle of  $\pm 40^\circ$ , the following are dimensions for the distance from the top surface of the sensor to the outside surface of the glass,  $d$ , and the width of the window,  $w$ . The distance from the center of the infrared emitter to the center of the PIN photodiode is 2.47 mm.

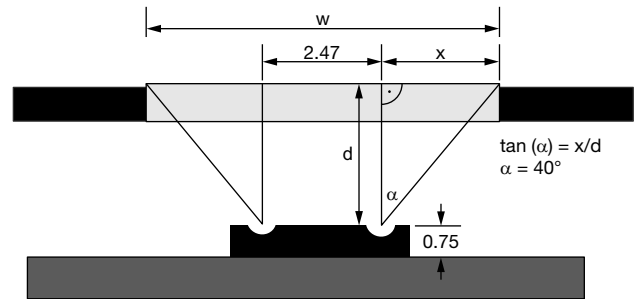

Fig. 8 - Window Dimensions

$d$ (mm)	$x$ (0.84 $d$ )	$w$ (2.47 + 2 $x$ )
0.5	0.42	3.31
1.0	0.84	4.15
1.5	1.26	4.99
2.0	1.68	5.83
2.5	2.10	6.67
3.0	2.52	7.51

The results above represent the ideal width of the window. The mechanical design of the device may not allow for this size. The sensor will function properly in less than ideal conditions. Performance testing is recommended in either case.

## Designing VCNL4000 into an Application

### PROXIMITY SENSOR

The main DC light sources found in the environment are sunlight and tungsten (incandescent) bulbs. These kinds of disturbance sources will cause a DC current in the detector inside the sensor, which in turn will produce noise in the receiver circuit. The negative influence of such DC light can be reduced by optical filtering. Light in the visible range, 400 nm to 700 nm, is completely removed by the use of an optical cut-off filter at 800 nm. With filtering, only longer wavelength radiation above 800 nm can be detected. The PIN photodiode therefore receives only a limited band from the original spectrum of these DC light sources as shown in fig. 9.

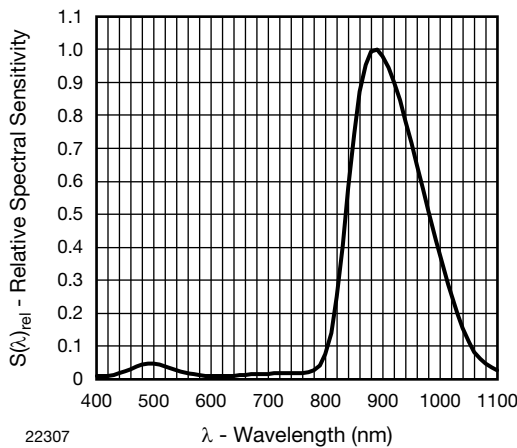

Fig. 9 - Spectral Sensitivity of PD

As mentioned earlier, the proximity sensor uses a modulated carrier signal on one of four user selected frequencies. These frequencies are far from the ballast frequencies of fluorescent lights ensuring that the sensor is unaffected by them. The infrared emitter sends out a series of pulses, a burst, at the selected frequency and the PIN photodiode which features a band pass filter set to this same frequency, receives the reflected pulses, fig. 10.

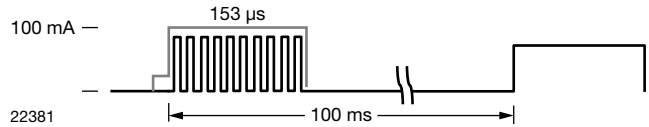
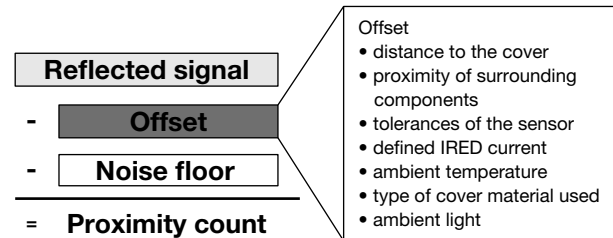

Fig. 10 - Emitter Pulses

In addition to DC light source noise, there is some reflection of the infrared emitted light off the surfaces which surround the VCNL4000. The distance to the cover, proximity of surrounding components, the tolerances of the sensor, the defined IRED current, the ambient temperature, and the type of material used all contribute to this reflection. The result of the reflection and DC noise yields a total offset count.

In addition to the offset, there is also a small noise floor during the proximity measurement which comes from the dc\_light suppression circuitry. This noise is in the range from ± 5 counts to ± 20 counts.

The application should “ignore” this offset as well the small noise floor and focus on the reflected pulses by subtracting them from the proximity readings.



22382

Fig. 11 - Proximity Calculation

The customer defines the detection algorithm used with the VCNL4000. As an example, an averaging routine will be used to demonstrate these calculations. The flowchart for determining the average offset level is shown in fig. 12.

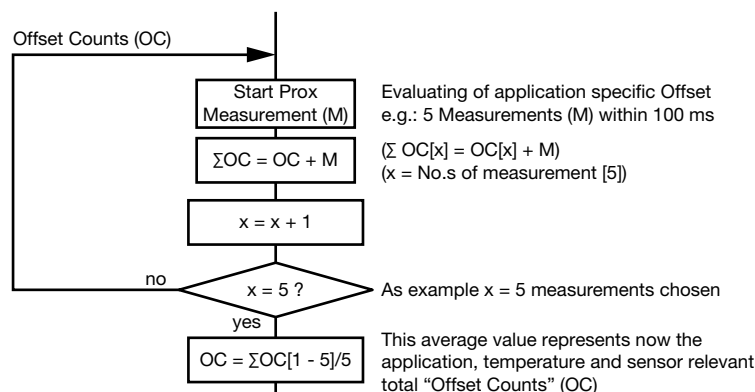
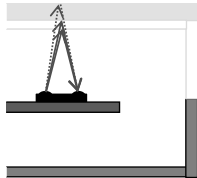

Fig. 12 - Flowchart for Determining Offset Counts

## Designing VCNL4000 into an Application

The VCNL4000 Demo Kit has an "Offset Compensation" function. If a plastic material which blocks 10 % of the infrared light is used to cover the sensor, the kit will display the proximity reading, fig. 13. This material can be used to represent a dirty, scratched surface and is more representative of the consumer applications in which the VCNL4000 will be used.



22383

The upper graph shows the full 16-bit response range while the lower graph shows the peak to peak range of the offset plus noise level. The offset plus noise has a range of just 19 counts from a minimum of 10 200 to a maximum of 10 219 counts. The

offset count is high because of the extra layer of less infrared-transparent material. However, this has no effect on the proximity measurement. Using the kit's "Offset Compensation" function, the offset value of 10 219 counts will be subtracted from the reflected signal count to yield the proximity count.

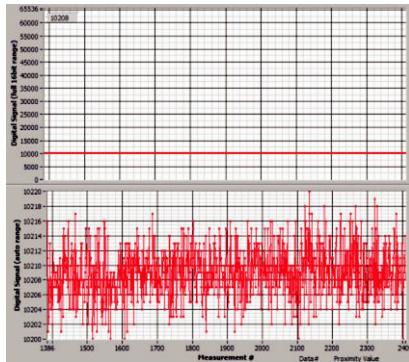

22384

Fig. 13 - Proximity Menu with VCNL4000 Demo Kit Software

PROXIMITY PARAMETERS		OFFSET AND NOISE	
Mode	On-demand	Minimum	10 200 cts
IRED current	100 mA	Maximum	10 219 cts
Rate	0.0138 s	Mean	10 209 cts

APPLICATION NOTE

In a second example, the ambient lighting conditions have changed slightly, resulting in a slightly higher offset level. Again, using the software that is included with the evaluation kit, the output of the sensor with an object present is shown in fig. 14. The upper graph shows the full 16-bit response range while the lower graph shows the peak to peak range. The maximum of the offset plus noise is 10 248 counts. This is the value that must be subtracted from the reflected signal count for proper response.

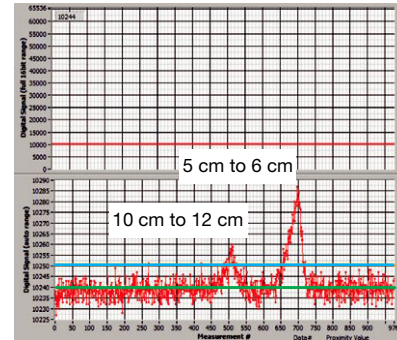

22385

Fig. 14 - Object Detection in Different Differences

PROXIMITY PARAMETERS		OFFSET AND NOISE	
Mode	On-demand	Minimum	10 231 cts
IRED current	100 mA	Maximum	10 248 cts
Rate	0.0138 s	Mean	10 239 cts

With an object at a distance of 10 cm, proximity measurement 510 in fig. 14, the difference between the maximum offset plus noise value (blue line) and the reflected signal is only 12 counts.

Given a threshold of  $T = 20$  counts, this is not enough to result in a proximity detection. The chosen threshold has been set due to the existing noise floor to achieve a reliable proximity signal.

If the average value of the offset plus noise, 10 239 counts (green line), is used, the proximity count is 21 counts and would result in detection. At 5 cm distance, the difference between the maximum offset plus noise level and the reflected signal is 37 counts. The object would be detected at 5 cm.

The effective range of VCNL4000 is from 1 mm to 20 cm. With the second layer of less transparent material, the operating range is reduced. Because the evaluation kit's software will always calculate the offset plus noise level and subtract it from the actual counts, the proximity sensor will work well in all lighting conditions, and with any transparent cover. This is true for the customer's application as well.

The flowchart for the proximity sensing using an average value algorithm including initialization and offset plus noise routine is shown in fig. 15. The VCNL4000 provides the proximity counts, the customer's application processes the counts to determine if a proximity event has occurred.

## Designing VCNL4000 into an Application

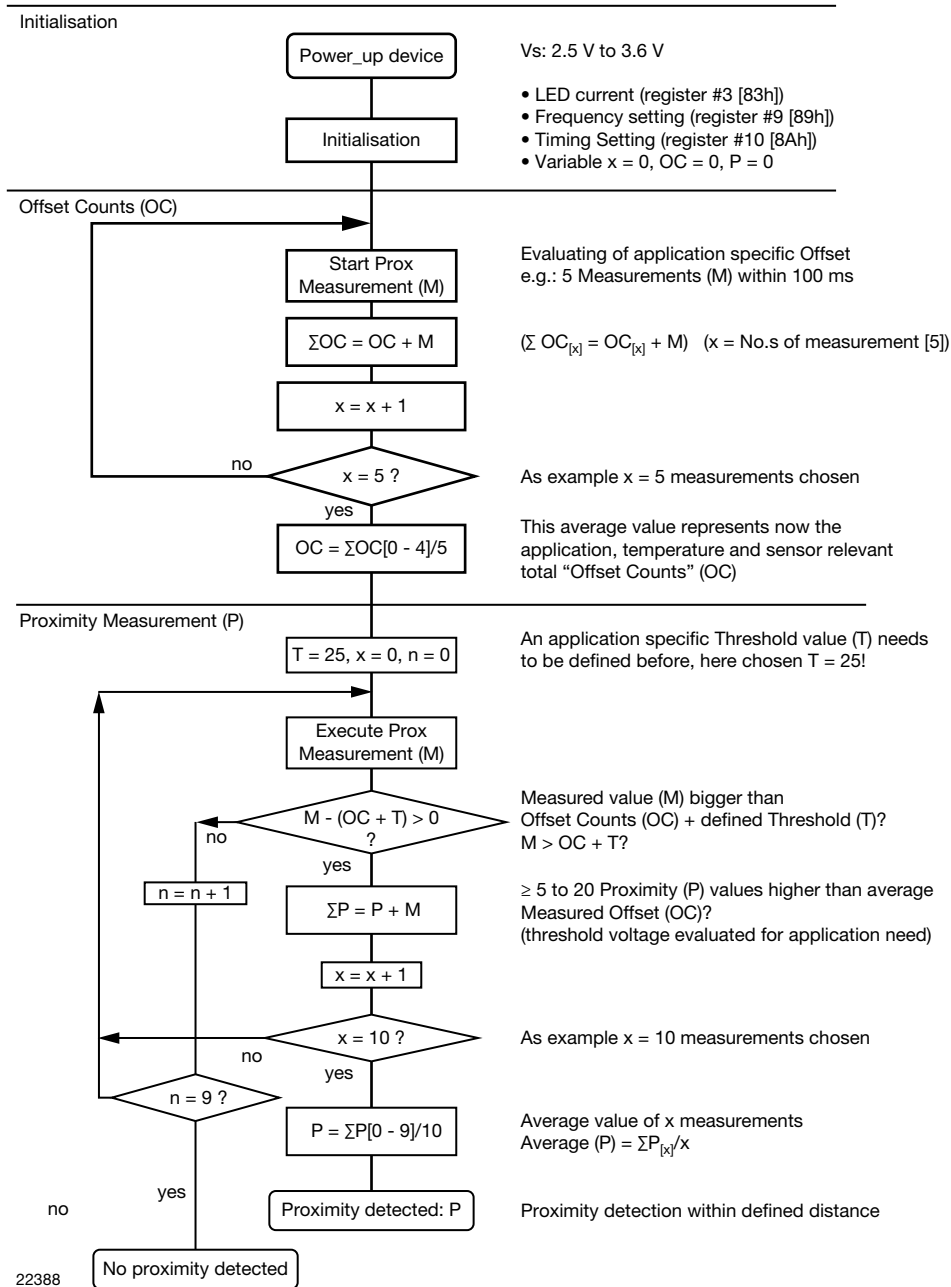

Fig. 15 - Flowchart for Proximity Sensing

## Designing VCNL4000 into an Application

Using a Kodak grey card which has 18 % reflectivity at varying distances yields the digital output counts in the graph shown below for infrared emitter currents of 20 mA, 100 mA, and 200 mA without a cover.

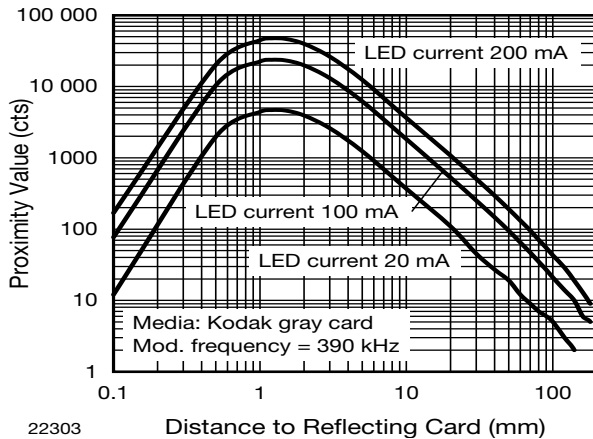

Fig. 16 - Proximity Values vs. Distance

### PROXIMITY CURRENT CONSUMPTION

The standby current of the VCNL4000 is 1.5  $\mu$ A. In this mode, only the I<sup>2</sup>C interface is active. In most consumer electronic applications the sensor will spend the majority of time in standby mode. For proximity sensing, the current consumption of the VCNL4000 is primarily a function of the infrared emitter current and, secondarily, signal processing done by the ASIC. Sample current consumption calculations are shown below for a range of IRED current and measurement rates. The current between burst pulse frames is equivalent to the standby mode. The duty cycle of the emitter is 50 %.

**10 measurement per second, emitter current = 100 mA**

$$\begin{aligned} \text{ASIC: } & 2.5 \text{ mA} \times 170 \mu\text{s}/1 \text{ s} \times 10 = & \mathbf{4.25 \mu\text{A}} \\ \text{IRED: } & 100 \text{ mA} \times 140 \mu\text{s}/1 \text{ s} \times 0.5 \times 10 = & \mathbf{70.00 \mu\text{A}} \\ \text{total: } & & \mathbf{74.25 \mu\text{A}} \end{aligned}$$

**250 measurement per second, emitter current = 200 mA**

$$\begin{aligned} \text{ASIC: } & 2.5 \text{ mA} \times 170 \mu\text{s}/1 \text{ s} \times 250 = & \mathbf{106.25 \mu\text{A}} \\ \text{IRED: } & 200 \text{ mA} \times 140 \mu\text{s}/1 \text{ s} \times 0.5 \times 250 = & \mathbf{3.50 \text{ mA}} \\ \text{total: } & & \mathbf{3.61 \text{ mA}} \end{aligned}$$

### INITIALIZATION AND I<sup>2</sup>C TIMINGS

The VCNL4000 contains twelve 8-bit registers for operation control, parameter setup and result buffering. All registers are accessible via I<sup>2</sup>C communication. fig. 24 shows the basic I<sup>2</sup>C communication with VCNL4000.

The built in I<sup>2</sup>C interface is compatible with all I<sup>2</sup>C modes: standard, fast and high speed. I<sup>2</sup>C H-Level voltage range is from 1.7 V to 5.0 V.

Please see also chapter “Register Functions” on page 10.

The following provides the timing related to taking a single proximity reading using an I<sup>2</sup>C bus operating at a standard speed of 100 kHz. At this speed, an 8-bit write or read command which includes the slave address, register, data, start, stop and acknowledge bits takes 100  $\mu$ s.

When the device is turned on, the VCNL4000 is powered on and initialized. Each write to a register requires 3 bytes or 300  $\mu$ s.

**Power Up of VCNL4000**

release of reset, start oscillator and signal processor **2.5 ms**

**Initialize VCNL4000**

Write to 3 registers **900  $\mu$ s**

- IR LED current
- Proximity measurement signal frequency
- Proximity modulator timing adjustment

Once the device is powered on and the device initialized, a proximity measurement can be taken. Before the first read out of the proximity count, a wait time is required. Subsequent reads do not require this wait time.

Start measurement	<b>300 <math>\mu</math>s</b>
Measurement being made	<b>170 <math>\mu</math>s</b>
Wait time prior to first read	<b>400 <math>\mu</math>s</b>
Read out of the proximity data	<b>600 <math>\mu</math>s</b>
<b>total:</b>	<b>1470 <math>\mu</math>s</b>

Using the averaging example in the flow chart above, taking 10 readings to establish the noise plus offset and 10 proximity readings, would result in a total time of 14.7 ms.

### AMBIENT LIGHT SENSING

Ambient light sensors are used to detect light or brightness in a manner similar to the human eye. They allow settings to be adjusted automatically in response to changing ambient light conditions. By turning on, turning off, or adjusting features, ambient light sensors can conserve battery power or provide extra safety while eliminating the need for manual adjustments.

Illuminance is the measure of the intensity of light incident on a surface and can be correlated to the brightness perceived by the human eye. In the visible range, it is measured in units called “lux.” Light sources with the same lux measurement appear to be equally bright. In fig. 17, the incandescent light and sunlight have been scaled to have the same lux measurement. In the infrared region, the intensity of the incandescent light is significantly higher. A standard silicon photodiode is much more sensitive to infrared light than visible light. Using it to measure ambient light will result in serious deviations between the lux measurements of different light sources and human-eye

## Designing VCNL4000 into an Application

perception. Using Vishay's ambient light sensors will solve this problem because they are most sensitive to the visible part of the spectrum.

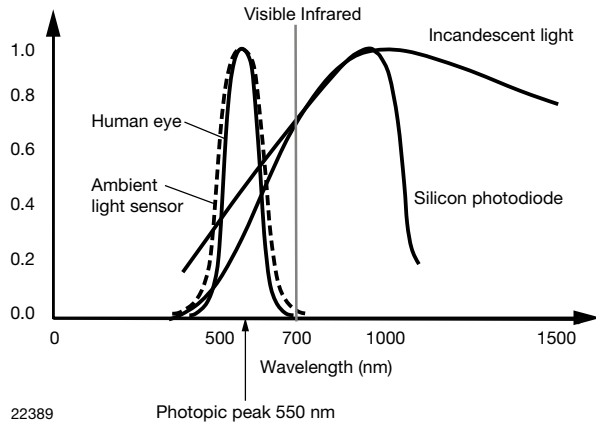

Fig. 17 - Relative Spectral Sensitivity vs. Wavelength

The human eye can see light with wavelengths from 380 nm to 780 nm. The Ambient Light Sensor closely matches this range of sensitivity and provides a digital output based on a 16 bit signal.

### AMBIENT LIGHT MEASUREMENT RESOLUTION AND OFFSET

The 16-bit digital resolution is equivalent to 65 536 counts. The ambient light sensors measurement resolution is 0.25 lux/count. This results to a measurement range from 0.25 lux to 16 383 lux with cover transparency of 100 %.

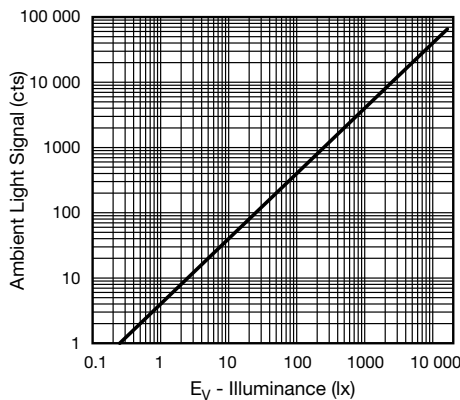

Fig. 18 - Ambient Light Values vs. Illuminance

If the cover which is placed above the sensor has a lower transparency due to a specific coating, the resolution of the sensor is reduced. Less visible light reaches the sensor due to the filter characteristic of some covers. The resulting sensor resolution in relation to cover transparency is shown in Table 11.

TABLE 11 - RESOLUTION VS. TRANSPARENCY	
COVER VISIBLE LIGHT TRANSPARENCY (%)	RESULTING SENSOR RESOLUTION (LUX/COUNT)
100	0.25
50	0.5
20	1.25
10	2.5

There is a general digital offset deviation of - 3 counts which has to be considered when setting up the application thresholds. This deviation comes from tolerances within the digital compensation process. Especially for low counts below less transparent cover these 3 counts should be added to the actual ambient light value and then the typically dividing factor of (averaged) 4 lead to the actual corresponding lux value.

### AMBIENT LIGHT SENSOR CURRENT CONSUMPTION

The ambient light sensor can operate in single or continuous mode. In single mode operation, an ambient light measurement consists of up to 128 individual measurement cycles which are averaged. The timing diagram for a single measurement is shown in fig. 20.

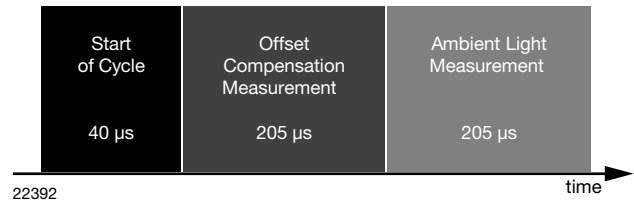

Fig. 19 - Timing Diagram for One Ambient Light Measurement Cycle

In single-mode operation, an ambient light measurement takes 100 ms. The single measurement cycles are evenly spread inside this 100 ms frame. fig. 21 shows an example where 8 single measurement cycles are averaged. The maximum number of single measurement cycles that can be used to calculate an average is 128. The maximum number of times this average can be calculated in one second is 10.

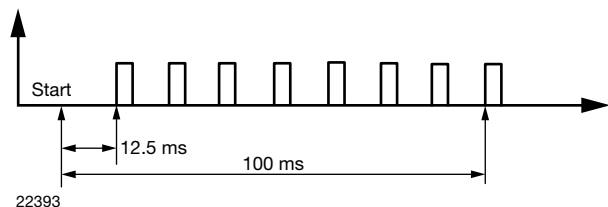

Fig. 20 - Ambient Light Measurement with Averaging = 8



## Designing VCNL4000 into an Application

A high number of averaging measurement cycles helps to reduce the influence of the frequency modulation of artificial lights.

During one measurement cycle, the ASIC consumes approximately 2.7 mA. Between the single measurements, the current consumption is 9  $\mu$ A. Sample current consumption calculations are shown below.

**Current Calculations for Ambient Light Measurements:**

**1 measurement per second, AVG = 32**

$$2.7 \text{ mA} \times 450 \text{ } \mu\text{s}/1 \text{ s} \times 32 = 39 \text{ } \mu\text{A}$$

**10 measurement per second, AVG = 128**

$$2.7 \text{ mA} \times 450 \text{ } \mu\text{s}/1 \text{ s} \times 128 \times 10 = 1.55 \text{ mA}$$

The current consumption for the ambient light sensor is strongly dependent on the number of measurements taken. In single-mode operation, the highest average current is 1.55 mA. Increasing the number of average measurements can further improve the reading at the expense of a higher current consumption, see “Current Calculations for Ambient Light Measurements” above.

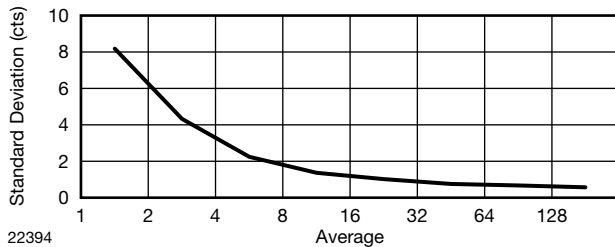

Fig. 21 - Ambient Light Noise vs. Averaging

In continuous conversion mode, the ambient light sensor measurement time can be reduced. A timing example of continuous mode where 8 measurements are averaged is shown in the following fig. 23.

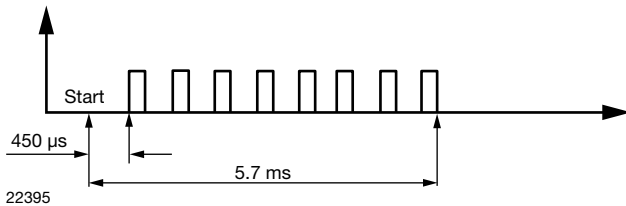

Fig. 22 - Ambient Light Measurement with Averaging = 8 Using Continuous Conversion Mode

The single measurements are done sequentially. One measurement cycle, including offset compensation, takes approximately 450  $\mu$ s. The gap time is 180  $\mu$ s. In the shown example the result is already accessible after about 6 ms. However, fluorescent light suppression is less effective in this mode.

### AMBIENT LIGHT INITIALIZATION AND I<sup>2</sup>C INTERFACE

For ambient light sensing, only register #4 parameters need to be initialized:

- Continuous conversion ON/OFF (register #4b7)
- Offset compensation ON/OFF (register #4b3)
- Number of average measurements (register #4b0 to 4b2)

The default settings are:

- Continuous conversion = OFF
- Offset compensation = ON
- Number of average measurements = 32

### REGISTER FUNCTIONS

The VCNL4000 has a fixed slave address for the host programming and accessing selection. The predefined 7 bit I<sup>2</sup>C bus address is set to 0010 011 = 13h. The least significant bit (LSB) defines read or write mode. Accordingly the bus address is set to 0010 011x = 26h for write, 27h for read.

VCNL4000 has twelve user accessible 8 bit registers.

The register addresses are 80h (register #0) to 8Bh (register #11).

**Note**

- Register #2 (82h) and register #11 (8Bh) are not intended to be used by customer.



## Designing VCNL4000 into an Application

Send byte    Write command to VCNL4000

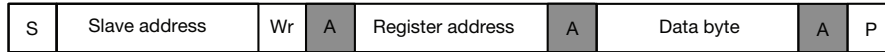

Receive byte    Read data from VCNL4000

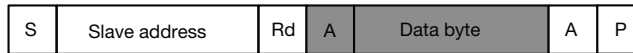
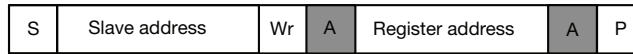

S = start condition  
P = stop condition  
A = acknowledge

Host action

VCNL4000 response

22313

Fig. 23 - Send Byte/Receive Byte Protocol

Please refer to the I<sup>2</sup>C specification from NXP for details.

### Register #0 Command Register

Register address = 80h

The register #0 is for starting ambient light or proximity measurements. This register contains 2 flag bits for data ready indication.

TABLE 1 - COMMAND REGISTER #0							
Bit 7	Bit 6	Bit 5	Bit 4	Bit 3	Bit 2	Bit 1	Bit 0
Config lock	als data rdy	Prox. data rdy	als od	Prox. od	N/A	N/A	N/A
Description							
Config lock	Read only bit. Value = 1						
als data rdy	Read only bit. Value = 1 when ambient light measurement data is available in the result registers. This bit will be reset when one of the corresponding result registers (reg #5, reg #6) is read.						
Prox. data rdy	Read only bit. Value = 1 when proximity measurement data is available in the result registers. This bit will be reset when one of the corresponding result registers (reg #7, reg #8) is read.						
als od	R/W bit. Starts a single on-demand measurement for ambient light. If averaging is enabled, starts a sequence of readings and stores the averaged result. Result is available at the end of conversion for reading in the registers #5 (HB) and #6 (LB).						
Prox. od	R/W bit. Starts a single on-demand measurement for proximity. Result is available at the end of conversion for reading in the registers #7 (HB) and #8 (LB).						

With setting bit 3 and bit 4 at the same write command, a simultaneously measurement of ambient light and proximity is done.

### Register #1 Product ID Revision Register

Register address = 81h. This register contains information about product ID and product revision.

Register data value of current revision = 11h.

TABLE 2 - PRODUCT ID REVISION REGISTER #1							
Bit 7	Bit 6	Bit 5	Bit 4	Bit 3	Bit 2	Bit 1	Bit 0
Product ID				Revision ID			
Description							
Product ID	Read only bits. Value = 1						
Revision ID							

### Register #2 without Function in Current Version

Register address = 82h.

APPLICATION NOTE



### Designing VCNL4000 into an Application

#### Register #3 LED Current Setting for Proximity Mode

Register address = 83h. This register is to set the LED current value for proximity measurement.

The value is adjustable in steps of 10 mA from 0 mA to 200 mA.

This register also contains information about the used device fuse program ID.

TABLE 3 - IR LED CURRENT REGISTER #3							
Bit 7	Bit 6	Bit 5	Bit 4	Bit 3	Bit 2	Bit 1	Bit 0
Fuse prog ID		IR LED current value					
<b>Description</b>							
Fuse prog ID		Read only bits. Information about fuse program revision used for initial setup/calibration of the device.					
IR LED current value		R/W bits. IR LED current = Value (dec.) x 10 mA. Valid Range = 0 to 20d. e.g.: 0 = 0 mA , 1 = 10 mA, ..., 20 = 200 mA (2 = 20 mA = DEFAULT) LED current is limited to 200 mA for values higher as 20d.					

#### Register #4 Ambient Light Parameter Register

Register address = 84h.

TABLE 4 - AMBIENT LIGHT PARAMETER REGISTER #4							
Bit 7	Bit 6	Bit 5	Bit 4	Bit 3	Bit 2	Bit 1	Bit 0
Cont. conv. mode	N/A			Auto offset compensation	Averaging function (number of measurements per run)		
<b>Description</b>							
Bit 7 Cont. conversion mode		R/W bit. Continuous conversion mode. Enable = 1; Disable = 0 = DEFAULT This function can be used for performing faster ambient light measurements.					
Bit 3 Auto offset compensation		R/W bit. Automatic offset compensation. Enable = 1 = DEFAULT; Disable = 0 In order to compensate a technology, package or temperature related drift of the ambient light values there is a built in automatic offset compensation function. With active auto offset compensation the offset value is measured before each ambient light measurement and subtracted automatically from actual reading.					
Bit 0 to bit 2 Averaging function		R/W bits. Averaging function. Bit values sets the number of single conversions done during one measurement cycle. Result is the average value of all conversions. Number of conversions = $2^{\text{decimal\_value}}$ e.g. 0 = 1 conv., 1 = 2 conv., 2 = 4 conv., ..., 7 = 128 conv. DEFAULT = 32 conv.					

#### Register #5 and #6 Ambient Light Result Register

Register address = 85h and 86h. These registers are the result registers for ambient light measurement readings.

The result is a 16 bit value. The high byte is stored in register #5 and the low byte in register #6.

TABLE 5 - AMBIENT LIGHT RESULT REGISTER #5							
Bit 7	Bit 6	Bit 5	Bit 4	Bit 3	Bit 2	Bit 1	Bit 0
<b>Description</b>							
Read only bits. High byte (15:8) of ambient light measurement result							

TABLE 6 - AMBIENT LIGHT RESULT REGISTER #6							
Bit 7	Bit 6	Bit 5	Bit 4	Bit 3	Bit 2	Bit 1	Bit 0
<b>Description</b>							
Read only bits. Low byte (7:0) of ambient light measurement result							



## Designing VCNL4000 into an Application

### Register #7 and #8 Proximity Measurement Result Register

Register address = 87h and 88h. These registers are the result registers for proximity measurement readings. The result is a 16 bit value. The high byte is stored in register #7 and the low byte in register #8.

TABLE 7 - PROXIMITY MEASUREMENT RESULT REGISTER #7							
Bit 7	Bit 6	Bit 5	Bit 4	Bit 3	Bit 2	Bit 1	Bit 0
<b>Description</b>							
Read only bits. High byte (15:8) of proximity measurement result							

TABLE 8 - PROXIMITY MEASUREMENT RESULT REGISTER #8							
Bit 7	Bit 6	Bit 5	Bit 4	Bit 3	Bit 2	Bit 1	Bit 0
<b>Description</b>							
Read only bits. Low byte (7:0) of proximity measurement result							

### Register #9 Proximity Measurement Signal Frequency

Register address = 89h.

TABLE 9 - PROXIMITY MEASUREMENT SIGNAL FREQUENCY REGISTER #9							
Bit 7	Bit 6	Bit 5	Bit 4	Bit 3	Bit 2	Bit 1	Bit 0
N/A						Proximity frequency	
<b>Description</b>							
Bit 0 and 1 Proximity frequency		R/W bits. Setting the proximity IR test signal frequency. The proximity measurement is using a square IR signal as measurement signal. Four different values are possible: 00 = 3.125 MHz 01 = 1.5625 MHz 02 = 781.25 kHz (DEFAULT) 03 = 390.625 kHz					

### Register #10 Proximity Modulator Timing Adjustment

Register address = 8Ah.

TABLE 10 - PROXIMITY MODULATOR TIMING ADJUSTMENT REGISTER #10							
Bit 7	Bit 6	Bit 5	Bit 4	Bit 3	Bit 2	Bit 1	Bit 0
Modulation delay time			N/A		Modulation dead time		
<b>Description</b>							
Modulation delay time		R/W bits. Setting a delay time between IR LED signal and IR input signal evaluation. This function is for compensation of delays from IR LED and IR photo diode. Also in respect to the possibility for setting different proximity signal frequency. Correct adjustment is optimizing measurement signal level.					
Modulation dead time		R/W bits. Setting a dead time in evaluation of IR signal at the slopes of the IR signal. This function is for reducing of possible disturbance effects. This function is reducing signal level and should be used carefully.					

#### Note

- The settings for best performance will be provided by Vishay. With first samples this is evaluated to: delay time = 4 and dead time = 1, with that register #10 should be programmed with: 129 (dez.)

### Register #11 Ambient IR Light Level Register

Register address = 8Bh. This register is not intended to be used by customer.

APPLICATION NOTE