



Designing the VCNL4030X01 Into an Application

By Reinhard Schaar

INTRODUCTION AND BASIC OPERATION

The VCNL4030X01 is a fully integrated proximity and ambient light sensor. It combines an infrared emitter, a photodiode for proximity measurement, an ambient light sensor, and signal processing IC in a single package with two 16-bit ADCs. The device provides ambient light sensing to support conventional backlight and display brightness auto-adjustment, and proximity sensing to minimize accidental touch inputs that can lead to call drops and camera launch.

With a range of up to 30 cm (12"), this component greatly simplifies the use and design-in of a proximity sensor in consumer and industrial applications. The VCNL4030X01 features a miniature, surface-mount 4.0 mm by 2.36 mm leadless package (LLP) with a low profile of 0.75 mm. The device is designed specifically to meet the low height requirements of smartphone, mobile phone, digital camera, and tablet PC applications.

Through its standard I²C bus serial digital interface, it allows easy access to "proximity signal" and "light intensity" measurements. The programmable interrupt function offers wake-up functionality for the microcontroller when a proximity event or ambient light change occurs, which reduces processing overhead by eliminating the need for continuous polling.

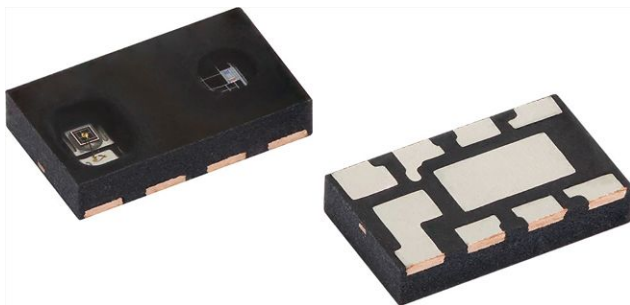

Fig. 1 - VCNL4030X01

COMPONENTS (BLOCK DIAGRAM)

The major components of the VCNL4030X01 are shown in the block diagram.

In addition to the ASIC with the ambient light and proximity photodiode, a powerful emitter is also implemented.

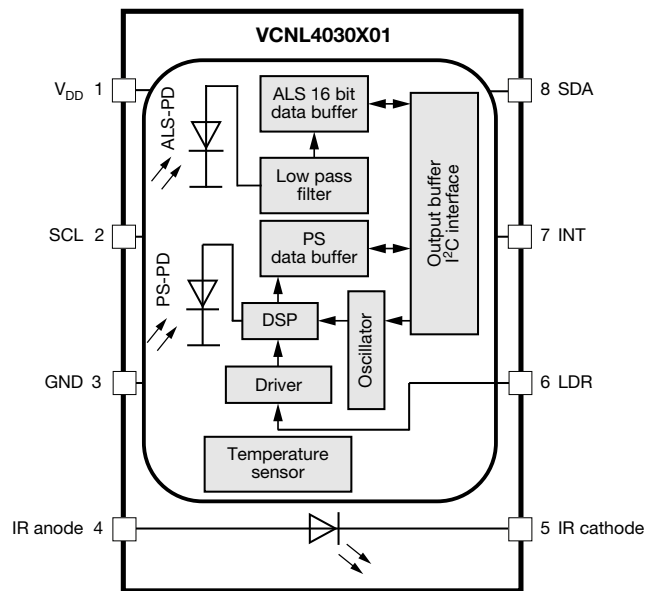

Fig. 2 - VCNL4030X01 Detailed Block Diagram

The internal infrared emitter comes with a peak wavelength of 940 nm to be totally in the "invisible" region but also good enough within the sensitivity of the proximity photodiode.

The ASIC has a programmable drive current from 50 mA to 200 mA in eight steps. The infrared light is emitted in short pulses with a programmable duty ratio from 1/40 to 1/320. The proximity photodiode receives the light that is reflected off the object and converts it to a current. It has a peak sensitivity of 850 nm. The sensitivity of the proximity stage is also programmable by choosing from eight different integration times. It is insensitive to ambient light. It ignores the DC component of light and compensates even for strong sunlight.

APPLICATION NOTE

Designing the VCNL4030X01 Into an Application

The ambient light sensor receives the visible light and converts it to a current. The human eye can see light with wavelengths from 380 nm to 780 nm, with a peak of 555 nm. Vishay's ambient light sensor closely matches this range of sensitivity. It has peak sensitivity at 540 nm and a bandwidth from 430 nm to 610 nm.

The application-specific integrated circuit, or ASIC, includes an LED driver, I²C bus interface, amplifier, integrated analog-to-digital converter, oscillator, and Vishay's "secret sauce" signal processor. For proximity, it converts the current from the photodiode to a 12-bit or 16-bit digital data output value. For ambient light sensing, it converts the current from the ambient light detector, amplifies it, and converts it to a 16-bit digital output stream.

PIN CONNECTIONS

Fig. 3 shows the pin assignments of the VCNL4030X01.

The connections include:

- Pin 1 - V_{DD} to the power supply
- Pin 2 - SCL to the microcontroller
- Pin 3 - connects to ground
- Pin 4 - IRED anode (to the power supply)
- Pin 5 - IRED cathode (to driver pin 6)
- Pin 6 - LDR (to IRED cathode)
- Pin 7 - INT to the microcontroller
- Pin 8 - SDA to the microcontroller

The power supply for the ASIC (V_{DD}) has a defined range from 2.5 V to 3.6 V. The anode of the infrared emitter can also be within this range. It is best if V_{DD} is connected to a regulated power supply and the anode of the IRED is connected directly to the battery. This eliminates any influence of the high infrared emitter current pulses on the V_{DD} supply line.

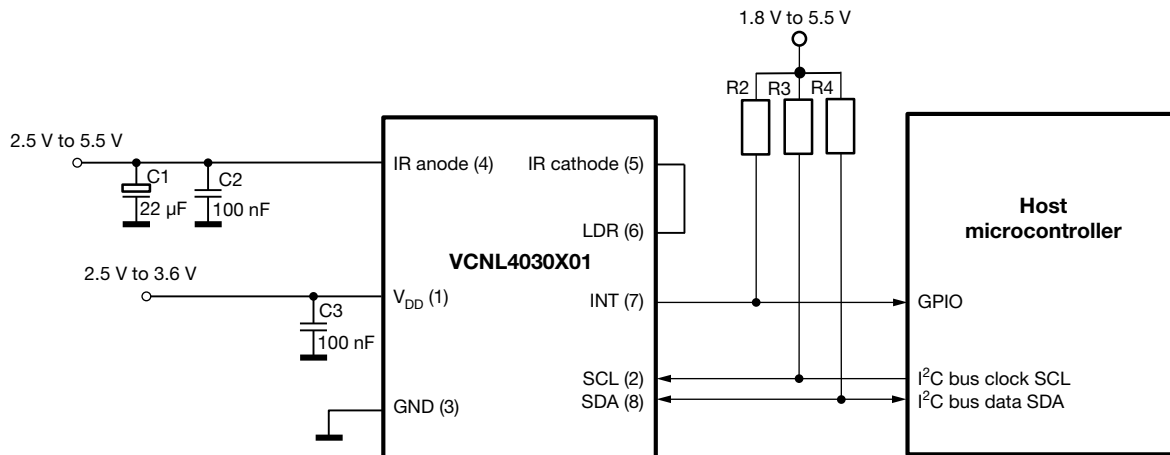

Fig. 3 - Circuitry With Two Separate Power Supply Sources

Three additional capacitors in the circuit are proposed for the following purposes: (1) the 100 nF capacitor near the V_{DD} pin is used for power supply noise rejection, (2) the 22 µF plus parallel 100 nF capacitors - connected to the anode of the IRED - are used to prevent the IRED voltage from instantly dropping when the IRED is switched on, and (3) 2.2 kΩ to 4.7 kΩ are recommended values for the pull-up resistor of the I²C. The value of the pull-up resistor at the INT line could be 10 kΩ.

Designing the VCNL4030X01 Into an Application

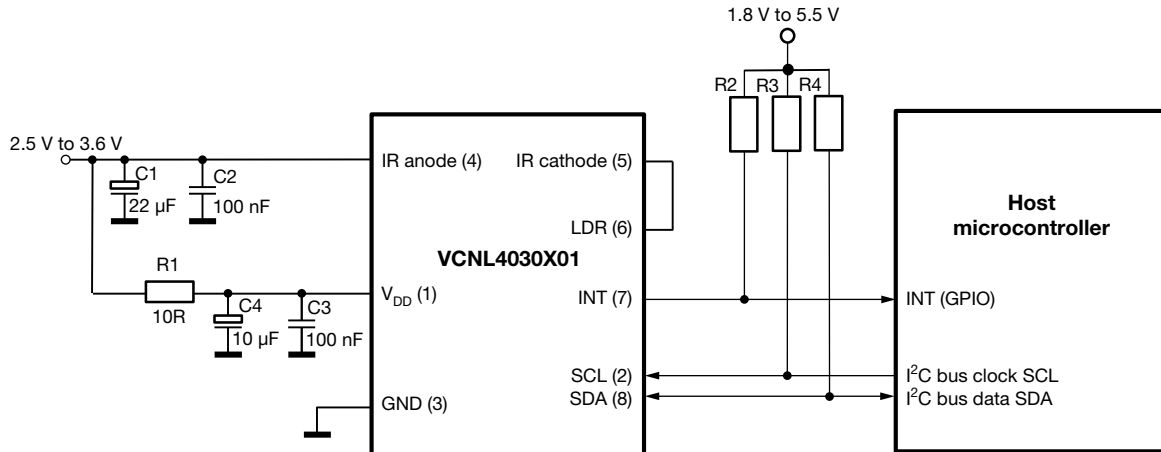

Fig. 4 - Circuitry With Just One Common Power Supply Source

For high currents of the IRED and / or power supply close to the lower limit of 2.5 V, this R-C decoupling will prevent the V_{DD} voltage drop below a specified minimum.

MECHANICAL DESIGN CONSIDERATIONS

The VCNL4030X01 comes with a very sensitive detector with high gain factors that requires a mechanical barrier to avoid direct crosstalk between emitter and detector. Placement below the application specific cover, possible close-by walls or other components will lead to crosstalk and with this to so-called offset counts. These total offset counts are fixed and can even be subtracted directly on-chip using the so-called “cancellation” register. Here the overall measured counts can be written in and are set to zero.

The only dimensions that the design engineer needs to consider are the distance from the top surface of the sensor to the outside surface of the window, and the size of the window. These dimensions will determine the size of the detection zone.

The relative radiant intensity of the emitter and the sensitivity of the photodiodes show an angle of half sensitivity of about $\pm 55^\circ$.

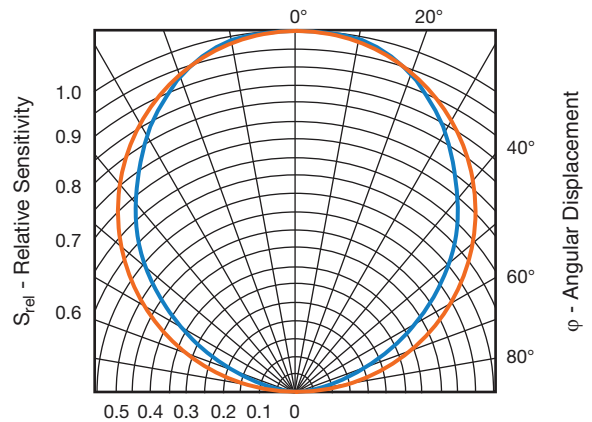

Fig. 5 - Relative Sensitivity vs. Angular Displacement (proximity sensor)

Designing the VCNL4030X01 Into an Application

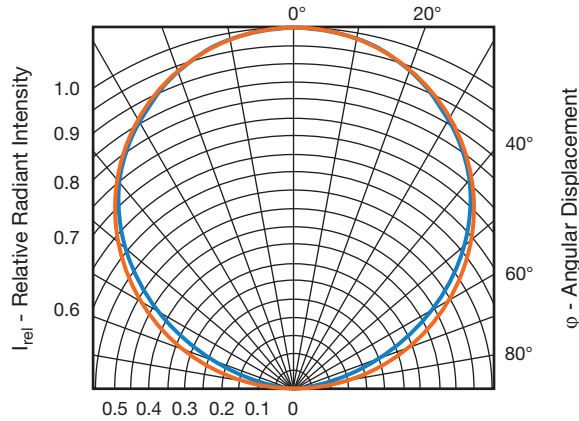

Fig. 6 - Relative Radiant Intensity vs. Angular Displacement

To achieve a good ambient light response, the diameter of the hole within the cover glass should not be too small. An angle of $\pm 30^\circ$ to $\pm 40^\circ$ will be sufficient in most applications. The package drawing shows the position of the photosensitive area. The 30° lines should be set at the sides of the opening. The following are dimensions for the distance from the top surface of the sensor to the outside surface of the glass (a) and the width of the window (d).

The best solution would be to use two single round holes, where the diameter should be at least wide enough so that the openings can freely look through; so, about 1.1 mm if the cover is directly on top of the sensor. For any gap between sensor and cover an additional light barrier could be needed.

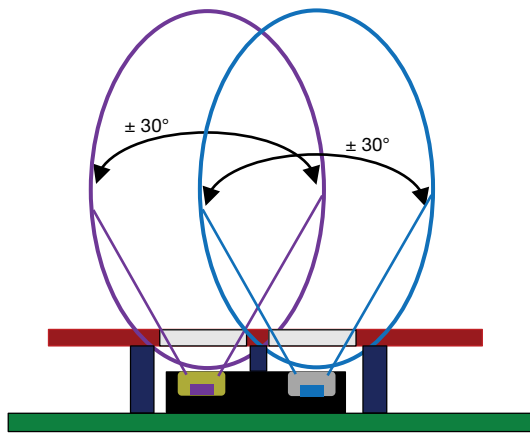

Fig. 7 - Proposal Angle of Relative Radiant Intensity and Sensitivity

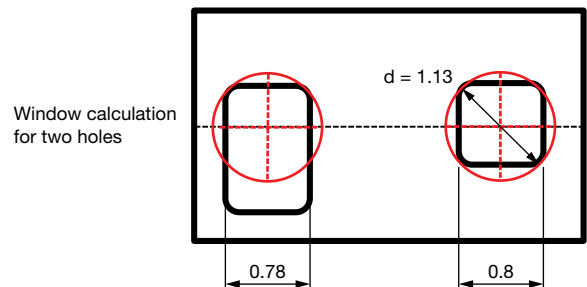

Fig. 8 - Light Hole Diameter (in millimeters)

The diameter needs to be increased with the distances between the sensor and cover glass according to the following calculation.

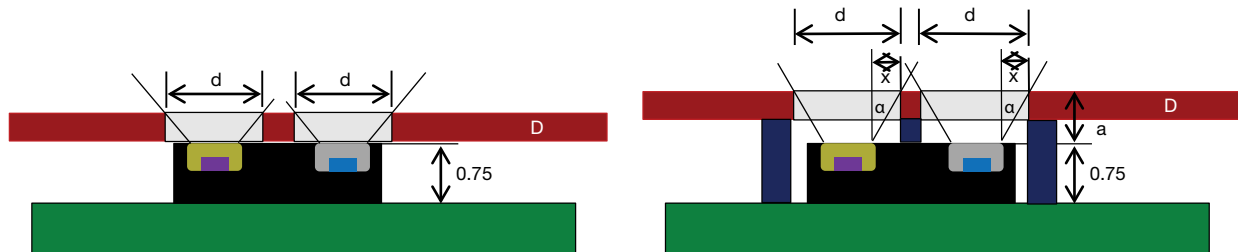

Fig. 9 - Window Dimensions (in millimeters)

The width calculation for distances from 0 mm to 1.0 mm results in:

$$\begin{aligned}
 a = 0.0 \text{ mm} &\rightarrow x = 0.00 \text{ mm} \rightarrow d = 1.1 \text{ mm} + 0.00 \text{ mm} = 1.10 \text{ mm} \\
 a = 0.5 \text{ mm} &\rightarrow x = 0.29 \text{ mm} \rightarrow d = 1.1 \text{ mm} + 0.58 \text{ mm} = 1.68 \text{ mm} \\
 a = 1.0 \text{ mm} &\rightarrow x = 0.58 \text{ mm} \rightarrow d = 1.1 \text{ mm} + 1.16 \text{ mm} = 2.26 \text{ mm}
 \end{aligned}$$

Designing the VCNL4030X01 Into an Application

PROXIMITY SENSOR

The main DC light sources found in the environment are sunlight and tungsten (incandescent) bulbs. These kinds of disturbance sources will cause a DC current in the detector inside the sensor, which in turn will produce noise in the receiver circuit. The negative influence of this DC light can be reduced by optical filtering, but is reduced much more efficiently by a so-called DC kill function. The proximity photodiode shows its best sensitivity at about 850 nm, as shown in Fig. 11.

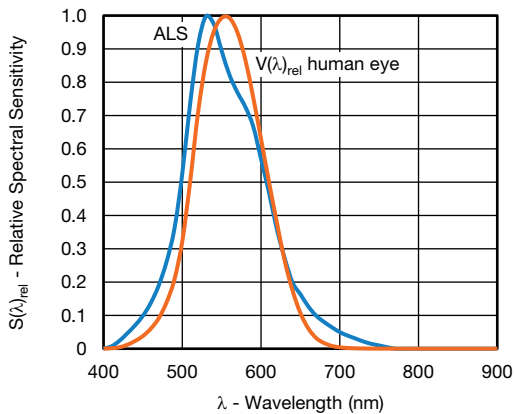

Fig. 10 - Normalized Spectral Response (ALS channel)

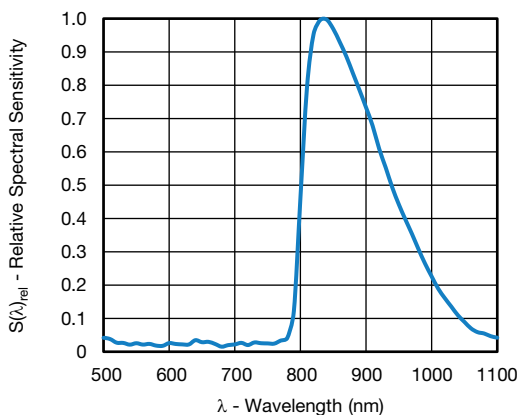

Fig. 11 - Normalized Spectral Response (PS channel)

The proximity sensor uses a short pulse signal of about 50 μ s ($PS_IT = 1T$) up to 400 μ s ($PS_IT = 8T$). The IRED on / off duty ratio setting now defines which repetition rate to be used, which can be programmed from 1/40 up to 1/320.

In addition to DC light source noise, there is some reflection of the infrared emitted light off the surfaces of the components surrounding the VCNL4030X01. The distance to the cover, proximity of surrounding components, tolerances of the sensor, defined infrared emitter current, ambient temperature, and type of window material used all contribute to this reflection. The result of the reflection and DC noise is the production of an output current on the proximity and light sensing photodiode. This current is converted into a count called the offset count.

In addition to the offset count, there could also be a small noise floor during the proximity measurement, which comes from the DC light suppression circuitry. This noise is typically just one or two counts. Only with light sources with strong infrared content could it be in the range from ± 5 counts to ± 10 counts.

The application should “ignore” this offset and small noise floor by subtracting them from the total proximity readings. The VCNL4030X01 offers a subtraction feature that automatically does this: PS_CANC . During the development of the end product, this offset count is evaluated and may now be written into register 5: PS_CANC_L/M . Now the proximity output data will just show the subtraction result of proximity counts - offset counts.

The results most often do not need to be averaged. If an object with very low reflectivity or at longer range needs to be detected, the sensor provides a register where the customer can define the number of consecutive measurements that the signal must exceed before producing an interrupt. This provides stable results without requiring averaging.

Designing the VCNL4030X01 Into an Application

PROXIMITY CURRENT CONSUMPTION

Both the ambient light sensor (ALS) and the proximity sensor (PS) within the VCNL4030X01 offer a separate shutdown mode. Default values after start-up have them both disabled. The application may activate just the one wanted or both.

The VCNL4030X01's embedded LED driver drives the IRED with a pulsed duty cycle. The IRED on / off duty ratio is programmable by an I²C command at register PS_Duty. Depending on this pulse / pause ratio, the overall proximity current consumption can be calculated. When higher measurement speed or faster response time is needed, PS_Duty may be selected to a maximum value of 1/40, which means one measurement will be made every 2 ms, but this will then also lead to the highest current consumption:

PS_Duty = 1/40: peak IRED current = 100 mA,
averaged current consumption is 100 mA/40 = 2.5 mA.

For proximity measurements executed just every 40 ms:
PS_Duty = 1/320 peak IRED current = 100 mA,
averaged current consumption is 100 mA/320 = 0.3125 mA.

The above is always valid for the normal pulse width of T = 1T = 50 μs, as well as for 2T, 4T, 8T, and all others in between. These pulse lengths are always doubled, resulting in 400 μs for 8T, but the repetition time is also doubled, ending in a period time of about 128 ms.

An extremely power-efficient way to execute proximity measurements is to apply a PS active force mode (register: PS_CONF3, command: PS_AF = 1).

If only a single proximity measurement needs to be done, PS_AF is set to "1" and then PS_SD = 0 = active. Setting PS_Trig = 1 will then execute just one single measurement.

In this mode, only the I²C interface is active. In most consumer electronic applications the sensor will spend the majority of time in sleep mode; it only needs to be woken up for a proximity or light measurement. In standby mode the power consumption is about 0.2 μA.

The pulse for proximity measurement looks to have a higher landing / step. This second trap is for smooth switch-off of the LED and is executed with very low IRED current. The pulse length in total is 200 μs. Amplitude of that first half is dependent on the IRED current. The higher this current is programmed, the higher that pulse amplitude will be. Taking a scope picture at IR_Cathode (pin 5) will look like shown with Fig. 12 and Fig. 13. IRED ON-time depending on programmed proximity integration time followed by a short switch-off time of about 5 μs.

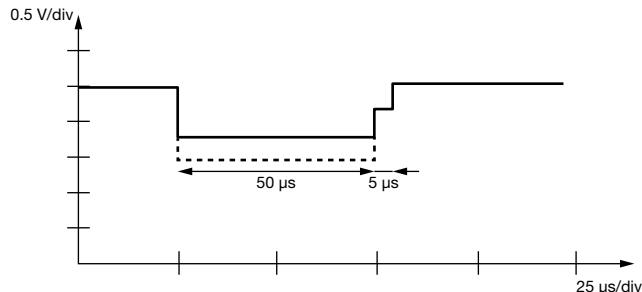

Fig. 12 - Proximity IRED Pulse for 1T

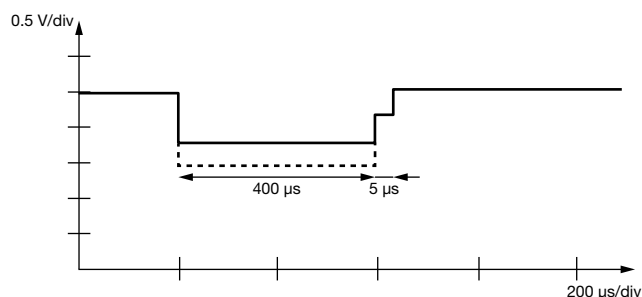

Fig. 13 - Proximity IRED Pulse for 8T

INITIALIZATION AND I²C TIMINGS

The VCNL4030X01 contains fifteen 16-bit command codes for operation control, parameter setup, and result buffering. All registers are accessible via I²C communication. The built-in I²C interface is compatible with the standard and high-speed I²C modes. The I²C H-level voltage range is from 1.7 V to 5.5 V.

There are only five registers out of the fifteen that typically need to be defined:

1. LED_I = 50 mA to 200 mA (IRED current)
REGISTER PS_MS #04 [0x04h]
2. PS_Duty = 1/40 to 1/320 (proximity duty ratio),
PS_IT (proximity integration time = pulse length),
PS_PERS (number of consecutive measurements above / below threshold), and PS_SD (PS power_on)
REGISTER PS_CONF1 #03 [0x03h]
3. ALS_IT (ALS integration time)
ALS_PERS (number of consecutive measurements above / below threshold), and
ALS_SD (ALS power_on)
REGISTER ALS_CONF #00 [0x00h]
4. and 5. Definition of the threshold value from the number of counts the detection of an object should be signaled.
Proximity TOP Threshold REGISTER
PS_THDL_L #06 [0x06h] for the low byte and
PS_THDL_H #07 [0x07h] for the high byte

Designing the VCNL4030X01 Into an Application

To define the infrared emitter current, as well as the integration time (length of the proximity pulsing), evaluation tests should be performed using the least reflective material at the maximum distance specified.

Fig. 14 shows the typical digital counts output versus distance that are seen when operated with max. IRED current of 200 mA and highest proximity integration time of 400 μ s. Here the so-called “two step” mode is used, and with PS_NS = 0 a four times higher gain is programmed for Fig.15 just the IRED current is reduced to avoid saturation for closer distances. The reflective reference medium is the Kodak Gray card. This card shows approximately 18 % reflectivity at 940 nm.

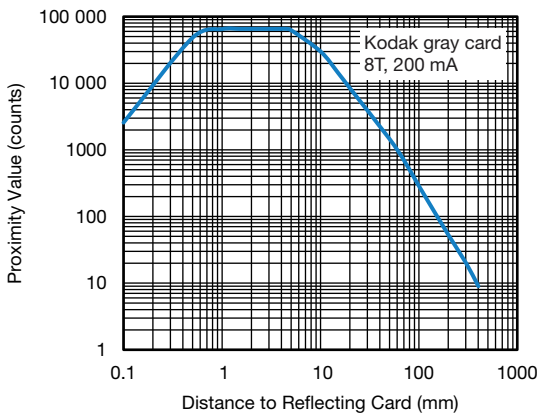

Fig. 14 - Proximity Value vs. Distance for 8T and 200 mA

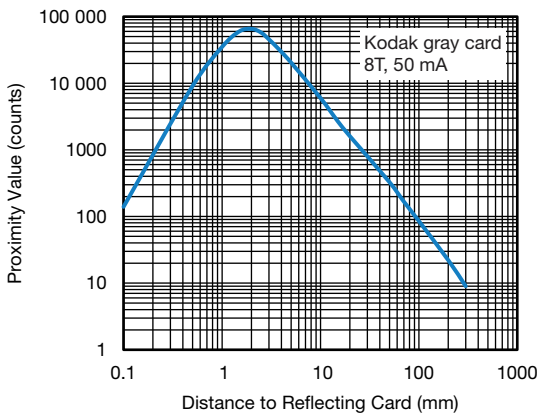

Fig. 15 - Proximity Value vs. Distance for 8T and 50 mA

This diagram shows the possible detection counts with a short pulse of 400 μ s and so-called “two step” mode. Another mode is the “single mode”. For single mode the conversion speed (travel voltage) is also possible to multiply x 8; this leads to about 8 times lower counts, but the noise figure is slightly better.

To eliminate disturbance by direct sunlight this “sunlight cancellation” the bit PS_SC_EN has to be set. In addition, the compensation current can be modified with PS_SC-CUR in four possible steps from “typical” up to eight times this typical current. The bit PS_SP, also enhances the sunlight cancellation capability by 50 %, typically. The bit PS_SPO defines the counts that should be presented if too strong sun light causes protection, either zero counts or max. counts, 65 535 in 16-bit mode.

In order to reach the high reflection counts of the Kodak Gray card, one has to define the proximity range to 16 bit, otherwise the 12-bit range would just lead to 4095 counts. This is possible to select with: PS_HD = 1 within PS_CONF2 byte of command code #3.

With defining the duty time (PS_Duty), the repetition rate = the number of proximity measurements per second (speed of proximity measurements) is defined. This is possible between 2 ms (about 500 measurements/s) by programming PS_Duty with 1/40 and 16 ms (about 62 measurements/s) with programming PS_Duty with 1/320.

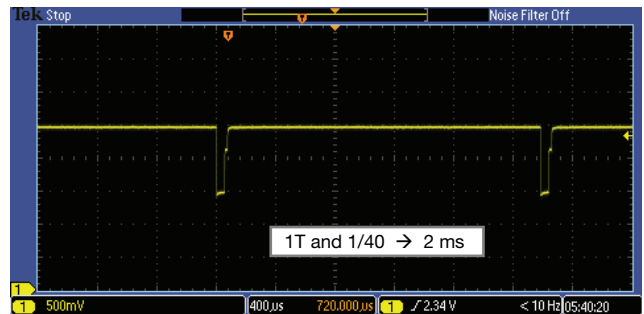

Fig. 16 - Proximity Measurements With PS_Duty = 1/40

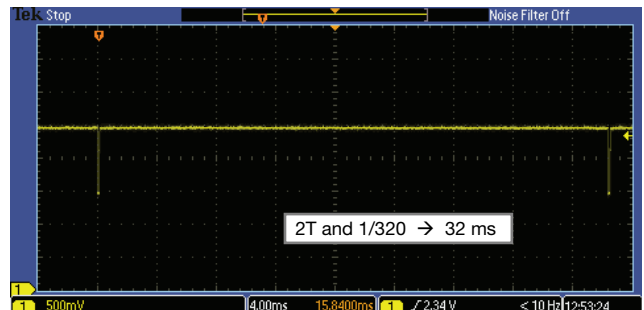

Fig. 17 - Proximity Measurements With PS_Duty = 1/320

Designing the VCNL4030X01 Into an Application

This duty cycle also determines how fast the application reacts when an object appears in, or is removed from, the proximity zone.

Reaction time is also determined by the number of counts that must be exceeded before an interrupt is set. This is possible to define with proximity persist: PS_PERS. Possible values are from 1 to 4.

To define all these register values, an evaluation test should be performed. The SensorXplorer™ allows you to perform evaluation tests and properly set the registers for your application. The kit as well as the VCNL4030X01 sensor board is available from any of Vishay's distributors; availability and price please check here: www.vishay.com/optoelectronics/SensorXplorer.

Timing

For an I²C bus operating at 100 kHz, to write or read an 8-bit byte, plus start (or stop) and bit acknowledgement, takes 100 μs. Together with the slave address byte and the 8-bit command code byte, plus the 16-bit data, this results in a total of 400 μs. When the device is powered on, the initialization with just these five registers needs 5 x 4 bytes (slave address, command register, and 16-bit data) for a total of 20 bytes. So, 20 x 100 μs = 2000 μs = 2 ms.

Send Byte → Write Command to VCNL4030X01

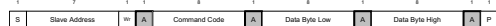

The read-out of 16-bit data would take a total of five bytes (slave address, command code, slave address with read bit set) and 16-bit data sent from the VCNL4030X01. So, 500 μs:

Receive Byte → Read Data from VCNL4030X01



Power Up

The release of the internal reset, the start of the oscillator, and the signal processor need **2.5 ms**

Initialize Registers

Write to four registers **1600 μs**

- IRED current
- Proximity duty ratio
- ALS integration time
- Proximity interrupt TOP threshold

Once the device is powered on and the VCNL4030X01 is initialized, a proximity measurement can be taken.

Asking for one forced proximity measurement **400 μs**

For (active forced, PS_IT = 8T)

Time to trigger [0.5 x PS_IT] **200 μs**

DC-kill ambient light [3 x PS_IT] **1200 μs**

Proximity measurement [1 x PS_IT] **400 μs**

IRED shutdown [1 x PS_IT] **400 μs**

Read out of the proximity data **500 μs**

total: **3100 μs**

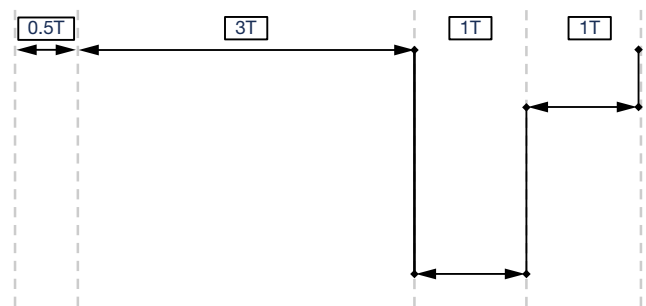

Fig. 18 - Timing Specification for Active Forced Mode

Designing the VCNL4030X01 Into an Application

AMBIENT LIGHT SENSING

Ambient light sensors are used to detect light or brightness in a manner similar to the human eye. They allow settings to be adjusted automatically in response to changing ambient light conditions. By turning on, turning off, or adjusting features, ambient light sensors can conserve battery power or provide extra safety by eliminating the need for manual adjustments.

Illuminance is the measure of the intensity of a light incident on a surface and can be correlated to the brightness perceived by the human eye. In the visible range, it is measured in units called "lux." Light sources with the same lux measurement appear to be equally bright. In Fig. 22, the incandescent light and sunlight have been scaled to have the same lux measurement.

In the infrared region, the intensity of the incandescent light is significantly higher. A standard silicon photodiode is much more sensitive to infrared light than visible light. Using it to measure ambient light will result in serious deviations between the lux measurements of different light sources and human eye perception. Using Vishay's ambient light sensors will solve this problem because they are most sensitive to the visible part of the spectrum.

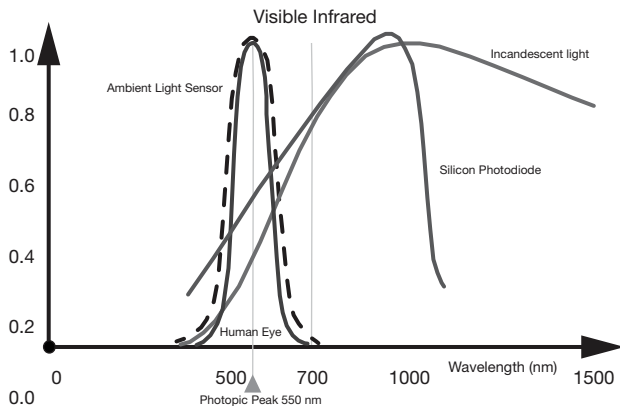

Fig. 19 - Relative Spectral Sensitivity vs. Wavelength

The human eye can see light with wavelengths from 400 nm to approximately 700 nm. The ambient light sensor array in the VCNL4030X01 closely matches this range of sensitivity and provides a digital output based on a 16-bit signal.

AMBIENT LIGHT MEASUREMENT, RESOLUTION, AND CALCULATION

The ambient light sensor's measurement resolution is defined to about 0.004 lux/step for the highest sensitivity, with a 800 ms integration time. The 16-bit digital resolution is equivalent to 65 536 counts. This yields a measurement range from 0.004 lux to 262 lux. For higher illuminance, a shorter integration time needs to be selected, which results in lower resolution.

ALS RESOLUTION AND MAXIMUM DETECTION RANGE

ALS_IT		SENSITIVITY	MAXIMUM DETECTION RANGE
ALS_IT (7 : 5)	INTEGRATION TIME (typ.)	UNIT (lx/step)	UNIT (lx)
(0, 0, 0)	50 ms	0.064	4192
(0, 0, 1)	100 ms	0.032	2096
(0, 1, 0)	200 ms	0.016	1048
(0, 1, 1)	400 ms	0.008	524
(1, 0, 0) to (1, 1, 1)		0.004	262

There are two option bits (ALS_HD and ALS_NS) that enhance the dynamic range by a factor of two each.

With this the sensitivity shown within table above will be reduced by the factor 2, but the maximum possible detection range will be doubled for both options. With this the max. detection range goes up to 4192 lx x 2 x 2 = 16 768 lx.

The sensitivity curve below shows the behavior of this ALS photodiode.

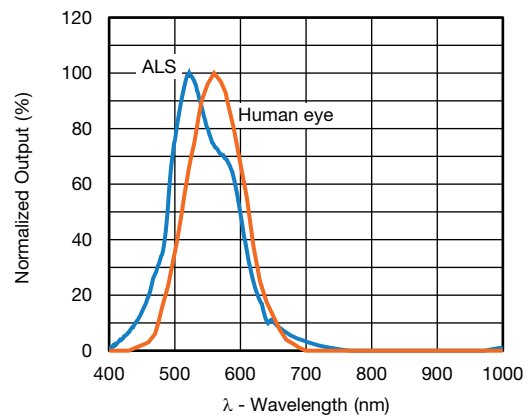

Fig. 20 - Relative Spectral Sensitivity vs. Wavelength

Besides the ALS, a white channel is also available.

Designing the VCNL4030X01 Into an Application

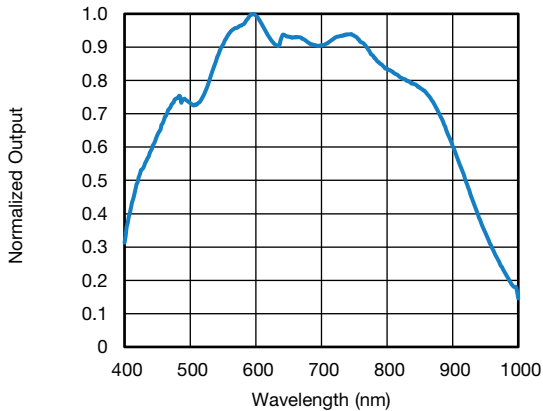

Fig. 21 - Relative Spectral Sensitivity vs. Wavelength (White Channel)

With the help of this white channel, more information can be determined, e.g. the kind of light source.

AMBIENT LIGHT SENSOR CURRENT CONSUMPTION

The ambient light sensor can operate with four selectable integration times from 50 ms to 800 ms.

During ALS measurements, the device consumes approximately 260 μ A.

AMBIENT LIGHT INITIALIZATION AND I²C INTERFACE

For ambient light sensing, only the low byte of command code #0 needs to be initialized:

- ALS_SD (bit 0 = 0 = ALS Power_on)
- ALS_INT_EN (bit 1 = 1 = ALS interrupt enable)
- ALS_PERS (bit 2, 3: no. of interrupt persistence)
- ALS_IT (bit 5, 6, 7: integration time)

The rate for self-timed measurements is dependent on the integration time.

For unknown brightness conditions, it should always be started with the shortest integration time. This avoids possible overload / saturation. Only if ambient light result register values are very low, e.g. no content within the high byte of the 16-bit register (#11), should the next more sensitive integration time be used.

Calculating the available lux level is done by multiplying the ambient light result value from register 11 (L and H byte) with the integration time / resolution.

Example: integration time is at 50 ms and 0x0BH and 0x0BL show 01010100 and 01110110, expressed in decimals: 21 622 counts leading to 21 622 x 0.064 to 1384 lx.

Within the ready-made application, this factor should be fine-tuned, as cover glass and the size of the opening will also impact the result.

Interrupt

The VCNL4030X01 features a very intelligent interrupt function. The interrupt function enables the sensor to work independently until a predefined proximity or ambient light event or threshold occurs. It then sets an interrupt, which requires the microcontroller to awaken. This helps customers reduce their software effort, and reduces power consumption by eliminating polling communication traffic between the sensor and microcontroller.

The interrupt pin, pin 6, of the VCNL4030X01 should be connected to a dedicated GPIO of the controller. A pull-up resistor is added to the same power supply that the controller is connected to. This INT pull-up resistor may be in the range of 8.2 k Ω to 100 k Ω .

The events that can generate an interrupt include:

1. A lower and an upper threshold for the proximity value can be defined. If the proximity value falls below the lower limit or exceeds the upper limit, an interrupt event will be generated. In this case, an interrupt flag bit in the read-out register 0x0B will be set and the interrupt pad of the VCNL will be pulled to low by an open drain pull-down circuit. In order to eliminate false triggering of the interrupt by noise or disturbances, it is possible to define the number of consecutive measurements that have to occur before the interrupt is triggered.
2. A lower and an upper threshold for the ambient light value can be defined. If the ambient light value falls below the lower limit or exceeds the upper limit, an interrupt event will be generated. There are two sets of high and low threshold registers, so both thresholds for proximity and ambient light can be observed in parallel.

Beside this “normal” interrupt mode, an automatic mode is also available, which is called the logic output mode.

This mode automatically pulls the interrupt pin low when an object exceeds the programmed upper threshold and also resets it if the lower threshold is exceeded. So no actions from the controller are needed if, for example, a smartphone is held close to an ear but quickly taken away (e.g. for a short look at the display).

Application Example

The following example will demonstrate the ease of using the VCNL4030X01 sensor. The VCNL4030X01 sensor board is an add-on board to the SensorXplorer. More information about this demo kit can be found at www.vishay.com/optoelectronics/SensorXplorer.

Please purchase a VCNL4030X01 sensor board at any listed distributors:

www.vishay.com/optoelectronics/SensorXplorer.

Designing the VCNL4030X01 Into an Application

Offset

During development, the application-specific offset counts for the sensor were determined. As previously mentioned, the offset count is affected by the components surrounding the VCNL4030X01, the window or cover being used, the distance from the sensor to the cover, and emitter intensity, which is controlled by the forward current.

In the following example, with a cover over the sensor and VSMY2940X01 emitter with emitter current set to 100 mA, the offset counts are 540 counts (Fig. 25). Offset counts vary by application and can be anywhere from 0 counts to several thousand counts. It is important to note that the offset count may change slightly over time due to, for example, the window becoming scratched or dirty, or being exposed to high temperature changes. If possible, the offset value should occasionally be checked and, if necessary, modified.

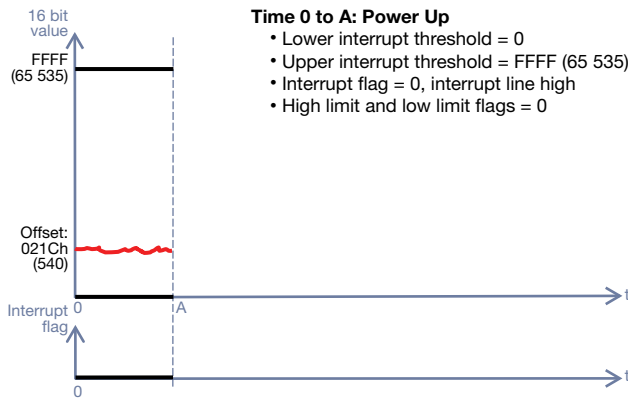

Fig. 22

Power Up

As mentioned, there are four variables for proximity measurement that need to be set in the register when the sensor is powered up: the emitter current, the number of occurrences that must exceed a threshold to generate an interrupt, the threshold values, and the number of proximity measurements per second.

The sensor should detect skin at a distance of 20 cm. Development testing determined that a current of 100 mA, together with a proximity integration time of $PS_IT = 8T$, produces adequate counts for detection. The proximity measurement rate is set so that about 20 measurements are done within a second and the number of occurrences to trigger an interrupt is set to four. Based on development testing, with a hand or skin approximately 20 cm above the window cover, the resulting total count is 550. This will be used as the upper threshold (high threshold).

For smartphone applications it would be typical to initially set this top threshold and a lower threshold (bottom threshold). This is needed to indicate the removal of the phone from the user's ear. The measured counts without any additional object close by will be around this offset count value, always below the lower threshold value, as shown in Fig. 26.

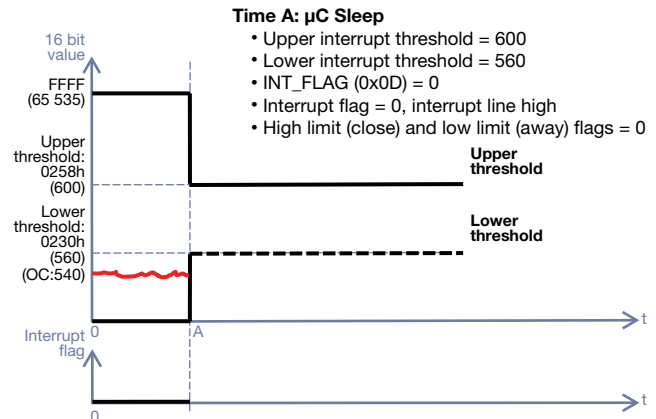

Fig. 23

By setting the number of occurrences before generating an interrupt to four, a single proximity value above or below the thresholds will have no effect, as shown in Fig. 27.

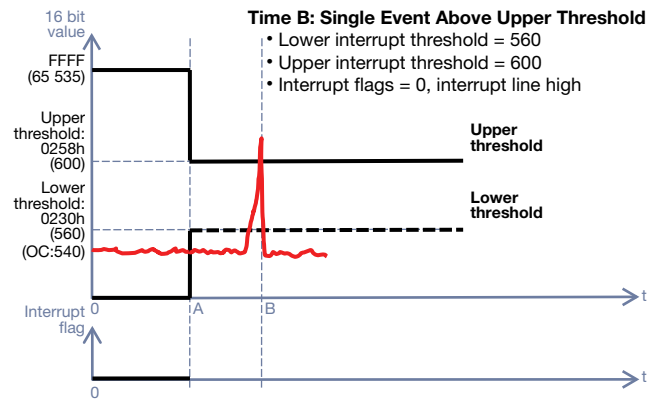

Fig. 24

A smartphone application will use a proximity sensor to detect when the phone is brought to the user's ear and disable the touchscreen and turn off the backlight. For other applications, such as automatic dispensing, the soap or towel will be dispensed.

Designing the VCNL4030X01 Into an Application

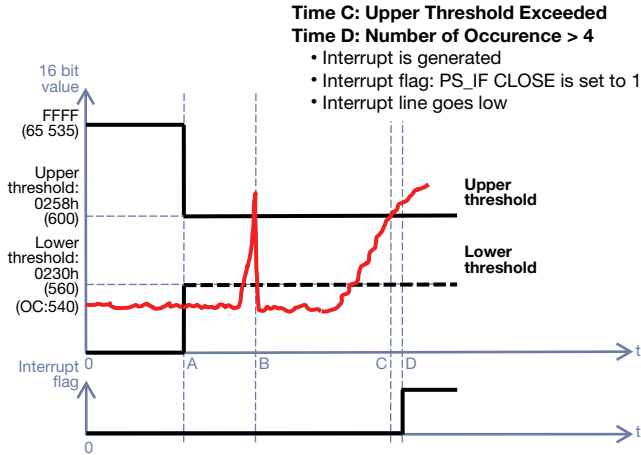

Fig. 25

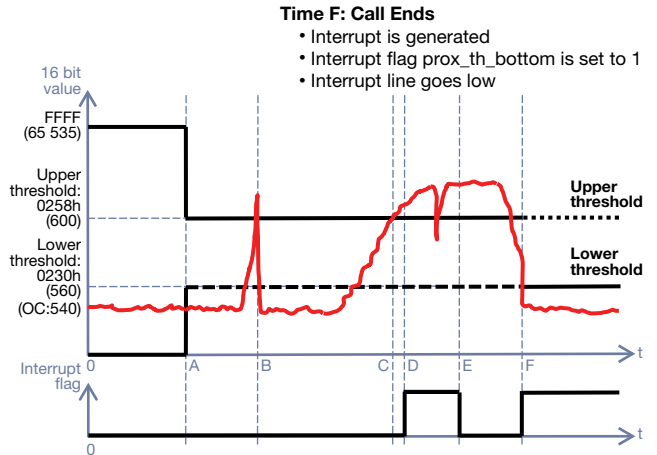

Fig. 26

In smartphone applications, the bottom threshold will also be programmed and waits for an interrupt signal. The prox_threshold_bottom should be set to “1” now and the prox_threshold_top cleared by entering a “1” again, since the phone is already next to the user’s ear. A lower threshold will occur when the phone call is complete and the phone is brought away from the user’s ear, and the backlight and touchscreen will be turned back on.

For this example, the upper threshold will only be set to 600 counts. The lower threshold is set to 560 counts; a value that is higher than the offset but low enough to indicate the removal of the phone from the user’s ear.

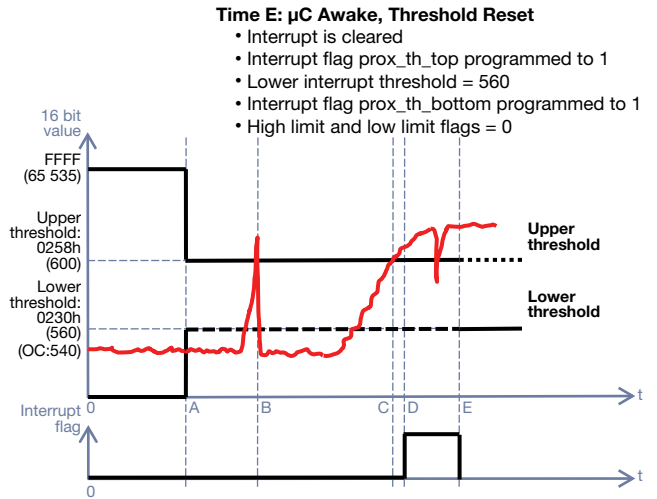
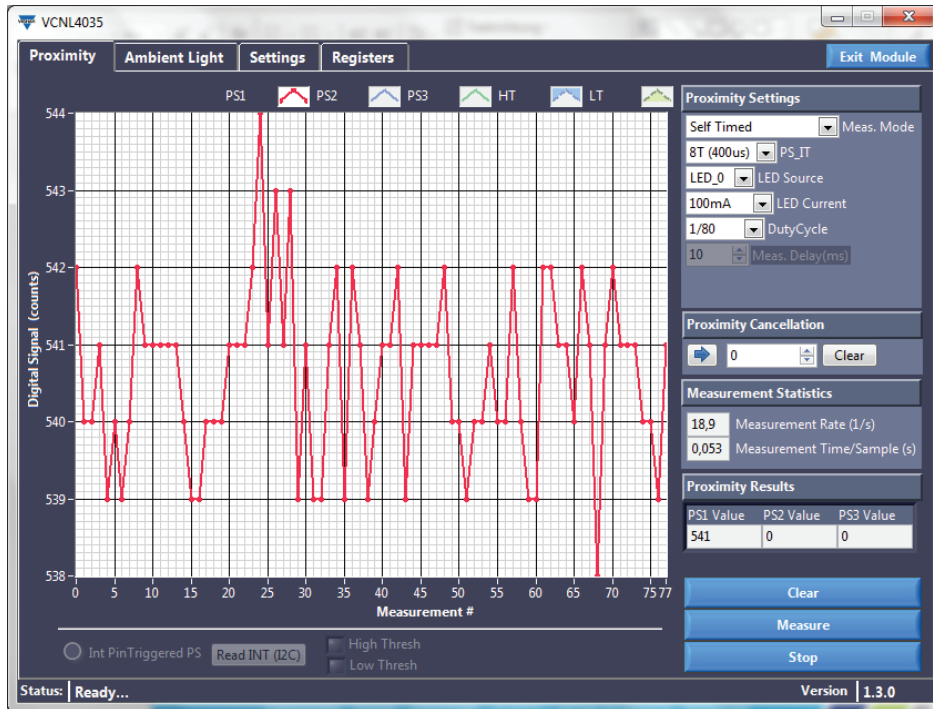

Fig. 27

Designing the VCNL4030X01 Into an Application

Some measurements and features are shown with the demo tool and demo software with a cover glass at about a 5 mm distance.

1. Proximity set-up with 8T wide pulses, 100 mA emitter current, and a duty cycle of 1/80, which results in about 30 measurements per second.



Designing the VCNL4030X01 Into an Application

2. If a hand or skin comes as close as 20 cm, these 540 counts rise up to more than 600 counts.

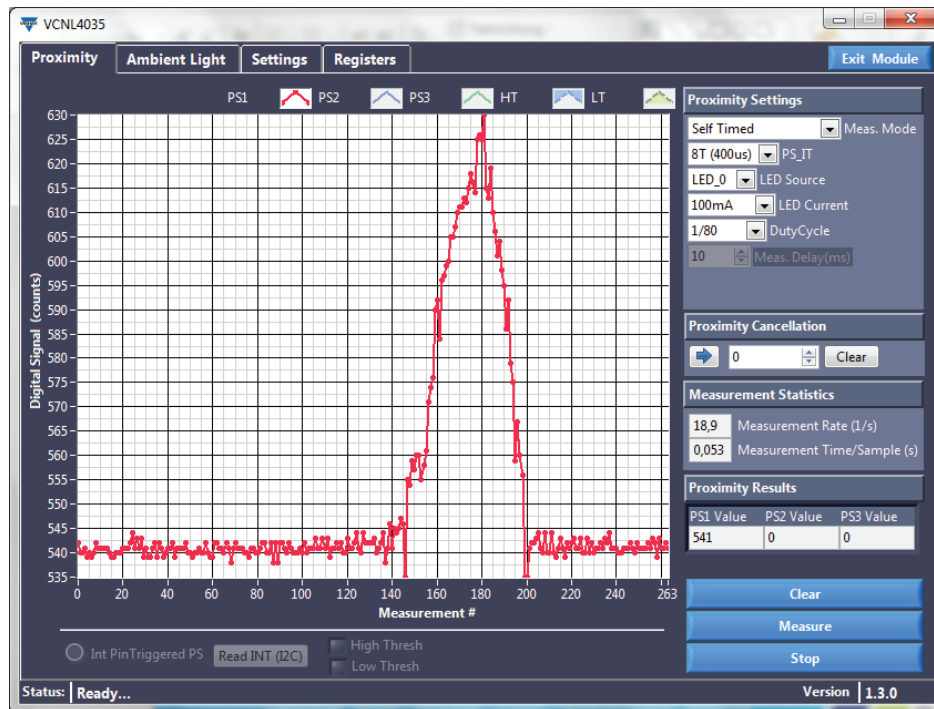

3. Here the thresholds are programmed as 600 for the upper and 560 for the lower. To see these, both “Show” buttons are activated. The presence of an object should only be recognized when four consecutive measurements are above that threshold.

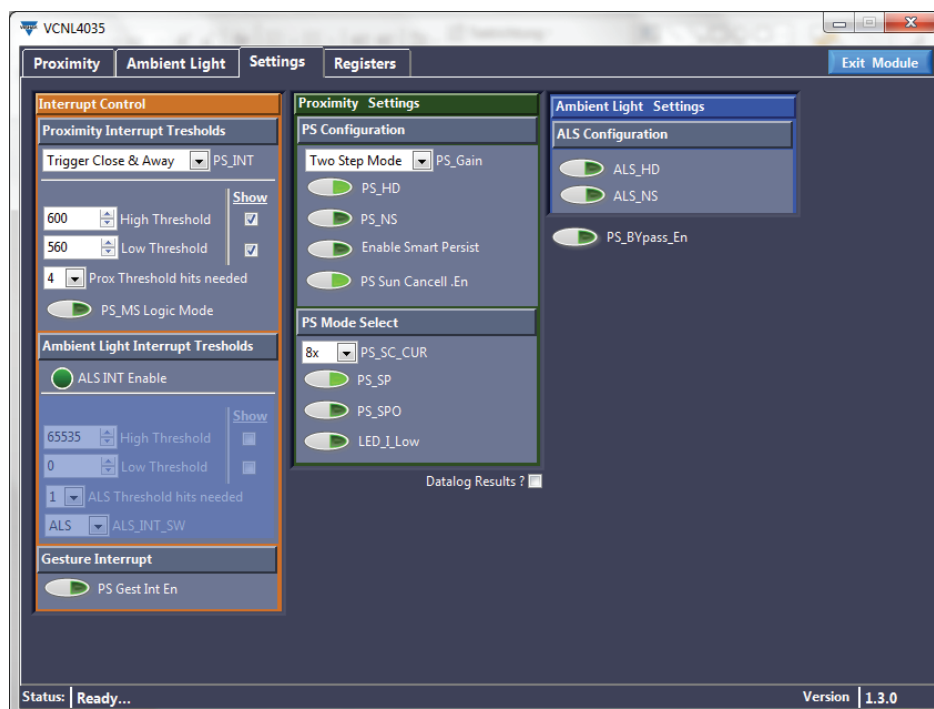

Designing the VCNL4030X01 Into an Application

4. Just one or two measurements above the threshold will not activate the interrupt.

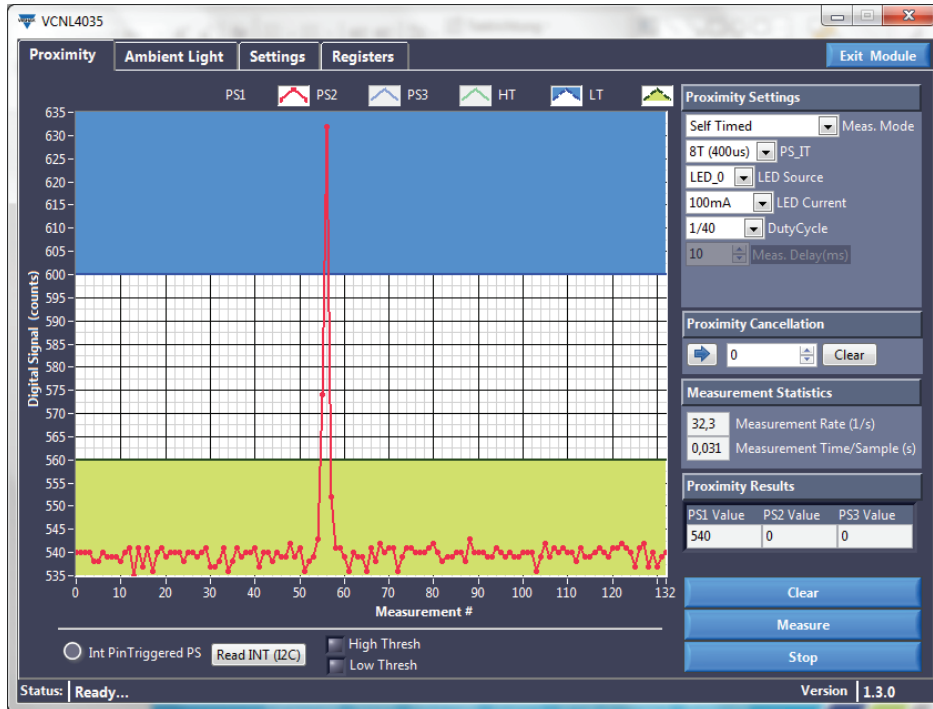

5. With more than four measurements above the threshold, however, the interrupt is pulled low, as indicated by the red LED on the demo board and the red light: “Int Pin Triggered PS.”

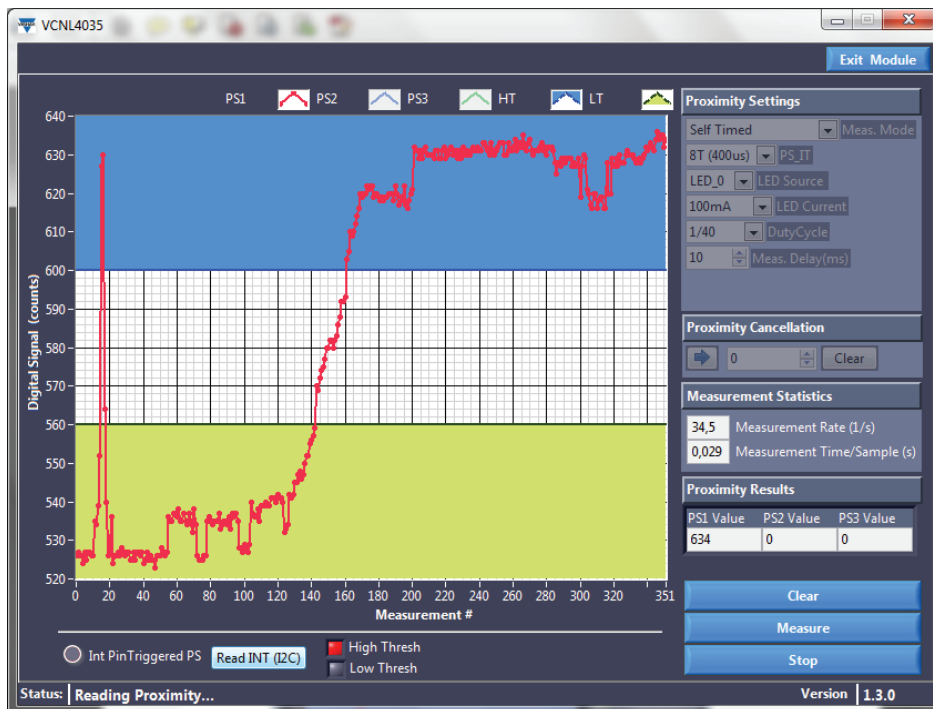

Designing the VCNL4030X01 Into an Application

6. The cancellation feature is used below. The “before seen” offset counts are subtracted. To do so, the value of 540 is entered for register number 05 = Prox_Cancellation.

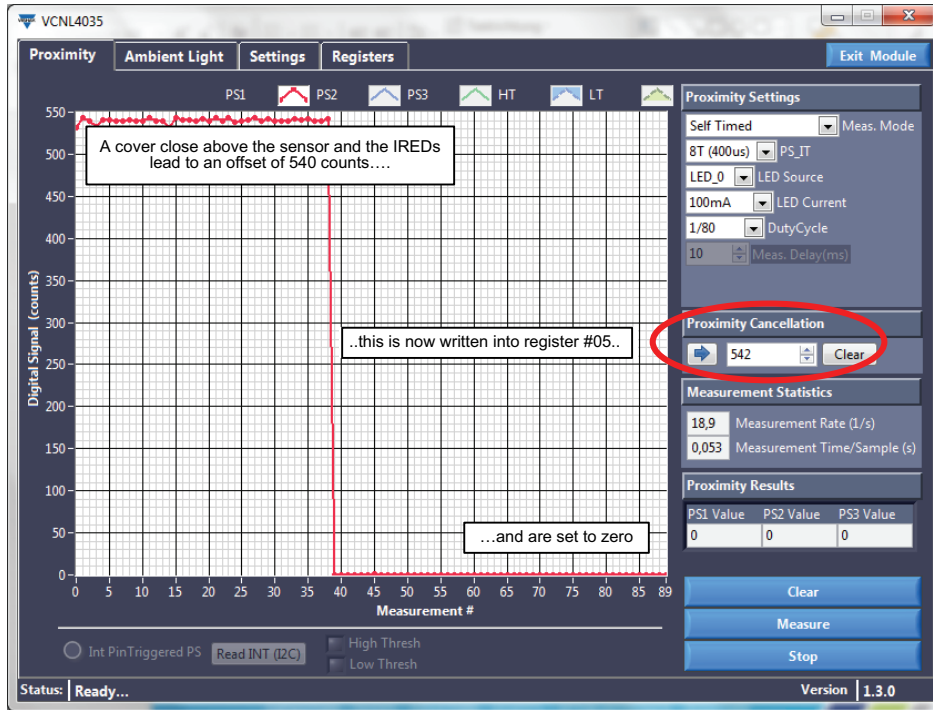

7. The “before seen” measured proximity result data of 541 is now $541 - 540 = 1$. Also, the thresholds are now 540 counts lower. The higher threshold is 10 and lower is just 5.

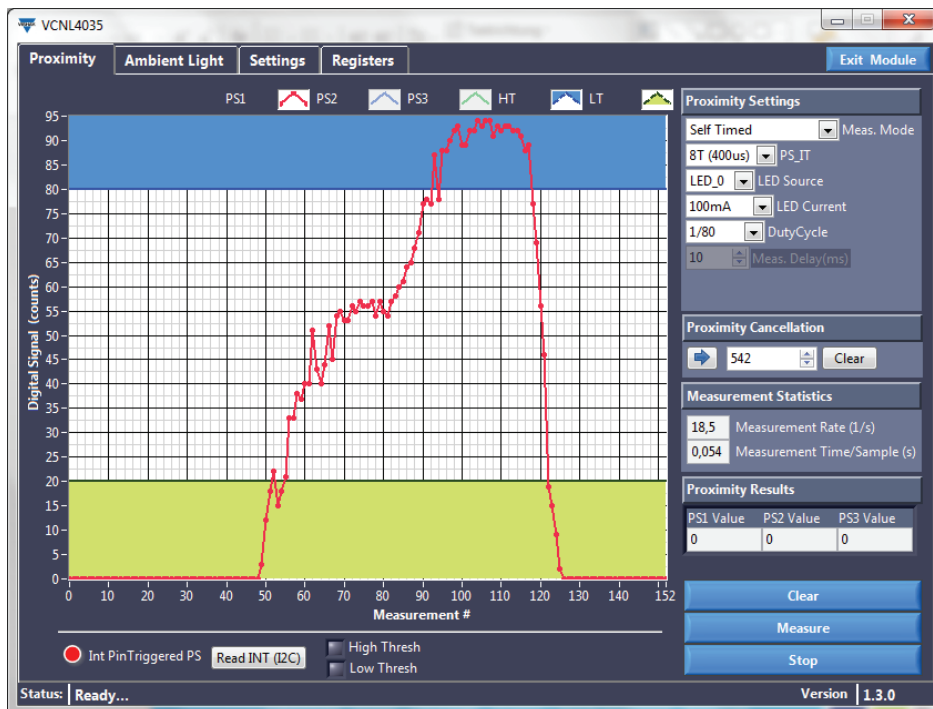

Designing the VCNL4030X01 Into an Application

If one chooses “logic mode” now and redefines the high threshold to 10 and low threshold as 5...

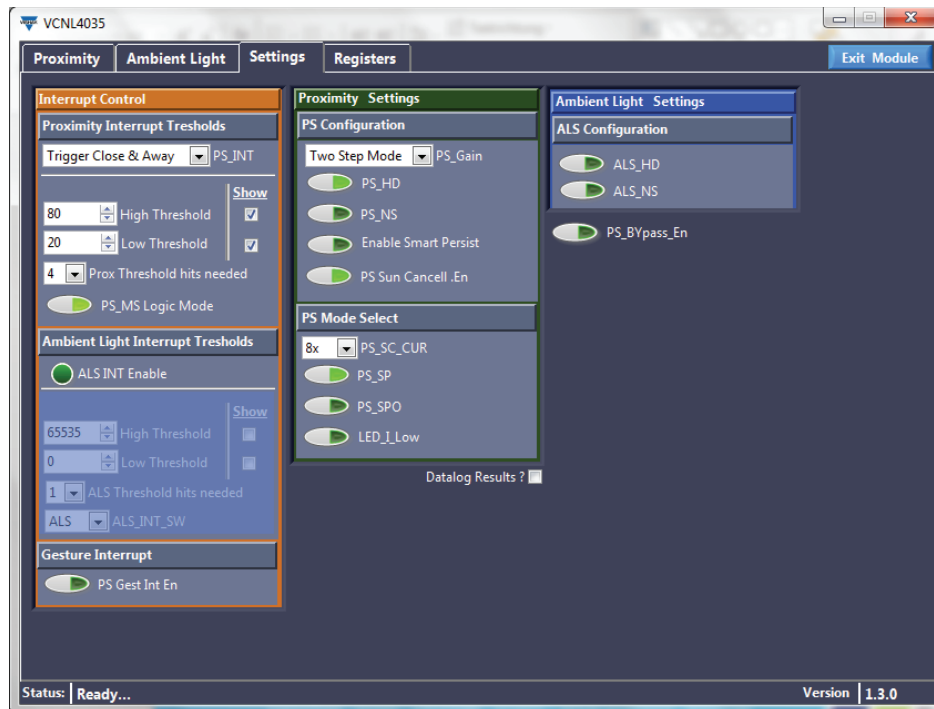

... the interrupt will indicate the rise above the upper threshold and will also automatically be cleared when it falls below the lower threshold.

One special feature for faster proximity measurements is also implemented, which is called “smart persist.”

This feature reduces the total reaction time until the interrupt is set to active, although four consecutive measurements should be above (or below) the defined threshold for safe acknowledgment.

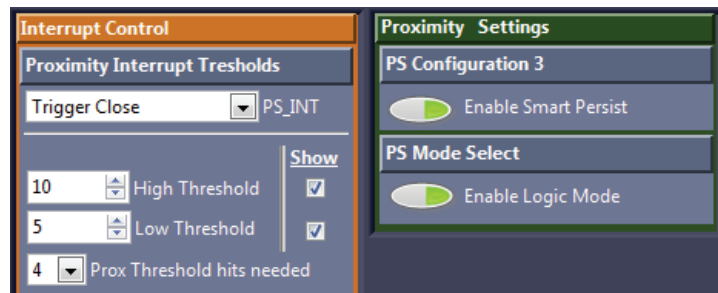

Designing the VCNL4030X01 Into an Application

Without “smart persist”, but with programmed hits above the defined threshold set to four, it will take four times the time of PS_Duty. With PS_IT = 1T and PS_Duty set to 1/320 this would be 4 x 16 ms.

With “smart persist” activated (bit 4 of PS_CONF3):

REGISTER: PS_CONF3 DESCRIPTION		
REGISTER: PS_CONF3		COMMAND CODE: 0x04_L (0x04 DATA BYTE LOW)
Command	Bit	Description
LED_I_LOW	7	0 = disabled = normal current, 1 = enabled = 1/10 of normal current, with that the current is accordingly: 5 mA, 7.5 mA, 10 mA, 12.5 mA, 17.5 mA, 20 mA
IRED select	6 : 5	(0 : 0) = IRED1, (0 : 1) = IRED2, (1 : 0) = IRED3, (1 : 1) = IRED3
PS_SMART_PERS	4	0 = disable; 1 = enable PS smart persistence
PS_AF	3	0 = active force mode disable (normal mode), 1 = active force mode enable
PS_TRIG	2	0 = no PS active force mode trigger, 1 = trigger one time cycle VCNL4030X01 output one cycle data every time host writes in ‘1’ to sensor. The state returns to ‘0’ automatically.
PS_MS	1	0 = proximity normal operation with interrupt function 1 = proximity detection logic output mode enable
PS_SC_EN	0	0 = turn off sunlight cancel; 1 = turn on sunlight cancel PS sunlight cancel function enable setting

or within the demo-tool:

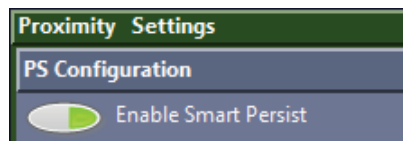

The total needed time is reduced to just one time of 16 ms, followed by three times of just 1.3 ms between the next three measurements, for a total of 39.7 ms.

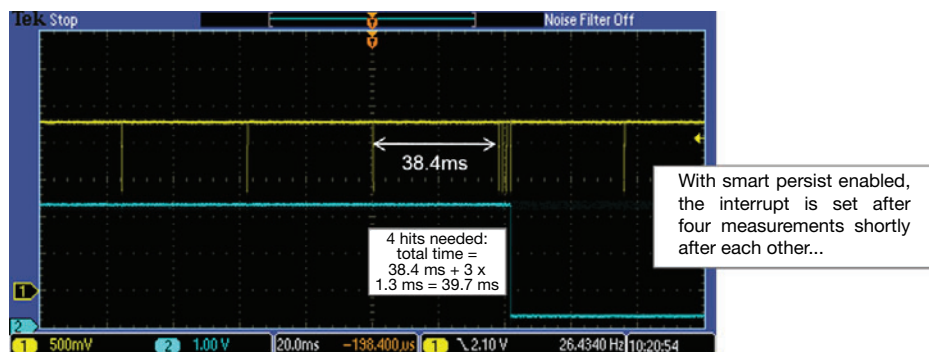

Remark:

With “smart persist” enabled, there will always be four pulses shortly after each other, whether PS_PERS is set to 2, 3, or 4.