



High Efficiency LED, Ø 5 mm Tinted Diffused Package



19223

DESCRIPTION

The tinted diffused 5 mm green LED series was developed for standard applications like general indicating and lighting purposes. It is using AllnGaP chip technology and includes the standard versions TLHG542. with stand-off and TLHG642... without stand-off. The wide viewing angle of these devices provides a high on-off contrast.

All LEDs are categorized in luminous intensity groups.

That allows users to assemble LEDs with uniform appearance.

PRODUCT GROUP AND PACKAGE DATA

- Product group: LED
- Package: 5 mm
- Product series: standard
- Angle of half intensity: $\pm 25^\circ$

FEATURES

- Standard T-1 $\frac{3}{4}$ package
- Wide viewing angle
- Luminous intensity and wavelength categorized
- TLHG542... with stand-offs, TLHG642... without stand-offs
- Material categorization: for definitions of compliance please see www.vishay.com/doc?99912

APPLICATIONS

- Status lights
- Off / on indicator
- Background illumination
- Readout lights
- Maintenance lights
- Legend light



PARTS TABLE														
PART	COLOR	LUMINOUS INTENSITY (mcd)			at I _F (mA)	WAVELENGTH (nm)			at I _F (mA)	FORWARD VOLTAGE (V)			at I _F (mA)	TECHNOLOGY
		MIN.	TYP.	MAX.		MIN.	TYP.	MAX.		MIN.	TYP.	MAX.		
TLHG5420	Green	6.3	20	-	10	562	570	575	10	-	2.1	2.4	20	AllnGaP on GaAs
TLHG5420-ASZ	Green	6.3	20	-	10	562	570	575	10	-	2.1	2.4	20	AllnGaP on GaAs
TLHG5420-KSZ	Green	6.3	20	-	10	562	570	575	10	-	2.1	2.4	20	AllnGaP on GaAs
TLHG6420	Green	6.3	20	-	10	562	570	575	10	-	2.1	2.4	20	AllnGaP on GaAs
TLHG6420-ASZ	Green	6.3	20	-	10	562	570	575	10	-	2.1	2.4	20	AllnGaP on GaAs
TLHG6420-CSZ	Green	6.3	20	-	10	562	570	575	10	-	2.1	2.4	20	AllnGaP on GaAs

**ABSOLUTE MAXIMUM RATINGS** ($T_{amb} = 25\text{ }^{\circ}\text{C}$, unless otherwise specified)
TLHG542., TLHG642.

PARAMETER	TEST CONDITION	SYMBOL	VALUE	UNIT
Reverse voltage		V_R	5	V
DC forward current		I_F	25	mA
Surge forward current	(Duty cycle 1/10 at 1 kHz)	I_{FSM}	60	mA
Power dissipation		P_V	60	mW
Junction temperature		T_j	100	$^{\circ}\text{C}$
Operating temperature range		T_{amb}	-40 to +85	$^{\circ}\text{C}$
Storage temperature range		T_{stg}	-40 to +100	$^{\circ}\text{C}$
Soldering temperature	$t \leq 5\text{ s}$, 2 mm from body	T_{sd}	260	$^{\circ}\text{C}$
Thermal resistance junction to solder point		R_{thJS}	325	K/W

OPTICAL AND ELECTRICAL CHARACTERISTICS ($T_{amb} = 25\text{ }^{\circ}\text{C}$, unless otherwise specified)
TLHG542., TLHG642., GREEN

PARAMETER	TEST CONDITION	PART	SYMBOL	MIN.	TYP.	MAX.	UNIT
Luminous intensity ⁽¹⁾	$I_F = 10\text{ mA}$	TLHG5420.	I_V	6.3	20	-	mcd
		TLHG6420.	I_V	6.3	20	-	mcd
Dominant wavelength	$I_F = 10\text{ mA}$		λ_d	562	570	575	nm
Peak wavelength	$I_F = 10\text{ mA}$		λ_p	-	571	-	nm
Angle of half intensity	$I_F = 10\text{ mA}$		ϕ	-	± 25	-	$^{\circ}$
Forward voltage ⁽²⁾	$I_F = 20\text{ mA}$		V_F	-	2.1	2.4	V
Reverse current	$V_R = 5\text{ V}$		I_R	-	-	10	μA
Junction capacitance	$V_R = 0\text{ V}$, $f = 1\text{ MHz}$		C_j	-	50	-	pF

Notes

- (1) In one packing unit $I_{Vmin}/I_{Vmax} \leq 0.5$
(2) Measurement uncertainty of forward voltage: $\pm 0.1\text{ V}$

LUMINOUS INTENSITY CLASSIFICATION

GROUP	LUMINOUS INTENSITY (mcd)		
	STANDARD	MIN.	MAX.
Q	6.3	12.5	
R	10	20	
S	16	32	
T	25	50	
U	40	80	
V	63	125	

Note

- Luminous flux is tested at a current pulse duration of 25 ms and an accuracy of $\pm 10\%$.
The above type numbers represent the order groups which include only a few brightness groups. Only one group will be shipped on each bag (there will be no mixing of two groups in each bag).
In order to ensure availability, single brightness groups will not be orderable.
In a similar manner for colors where wavelength groups are measured and binned, single wavelength groups will be shipped on any one bag.
In order to ensure availability, single wavelength groups will not be orderable.

COLOR CLASSIFICATION

GROUP	DOM. WAVELENGTH (nm)	
	GREEN	
	MIN.	MAX.
3	562	565
4	564	567
5	566	569
6	568	571
7	570	573
8	572	575

Note

- Wavelengths are tested at a current pulse duration of 25 ms and an accuracy of 1 nm

TYPICAL CHARACTERISTICS ($T_{amb} = 25\text{ }^{\circ}\text{C}$, unless otherwise specified)

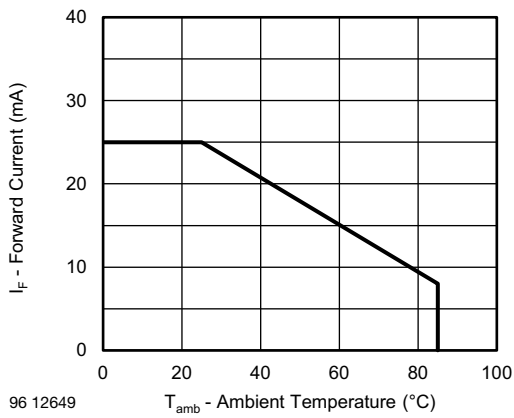

Fig. 1 - Forward Current vs. Ambient Temperature

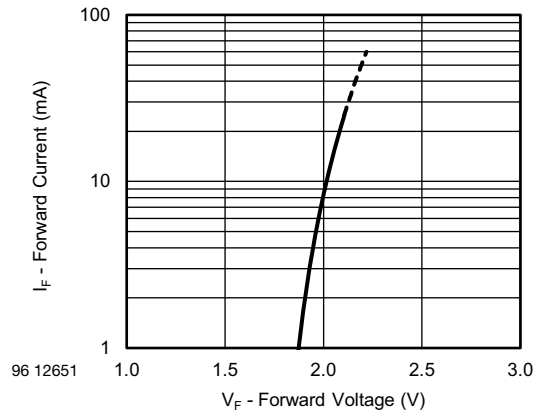

Fig. 4 - Forward Current vs. Forward Voltage

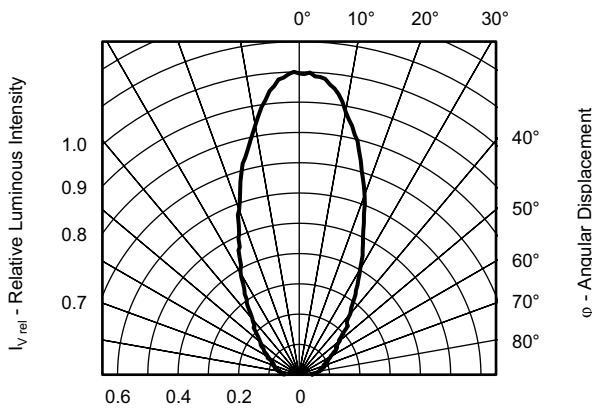

Fig. 2 - Rel. Luminous Intensity vs. Angular Displacement

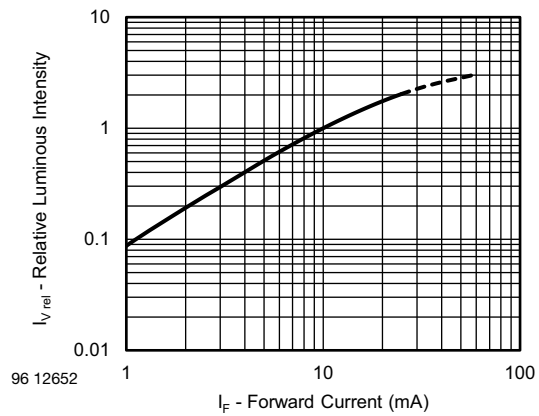

Fig. 5 - Relative Luminous Intensity vs. Forward Current

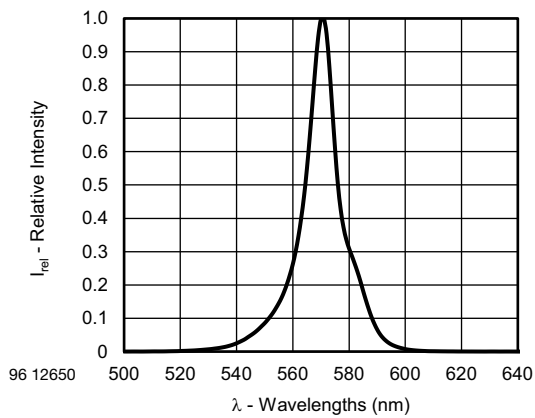

Fig. 3 - Relative Intensity vs. Wavelength

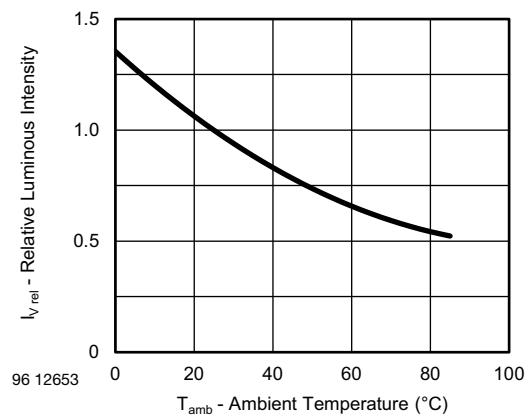
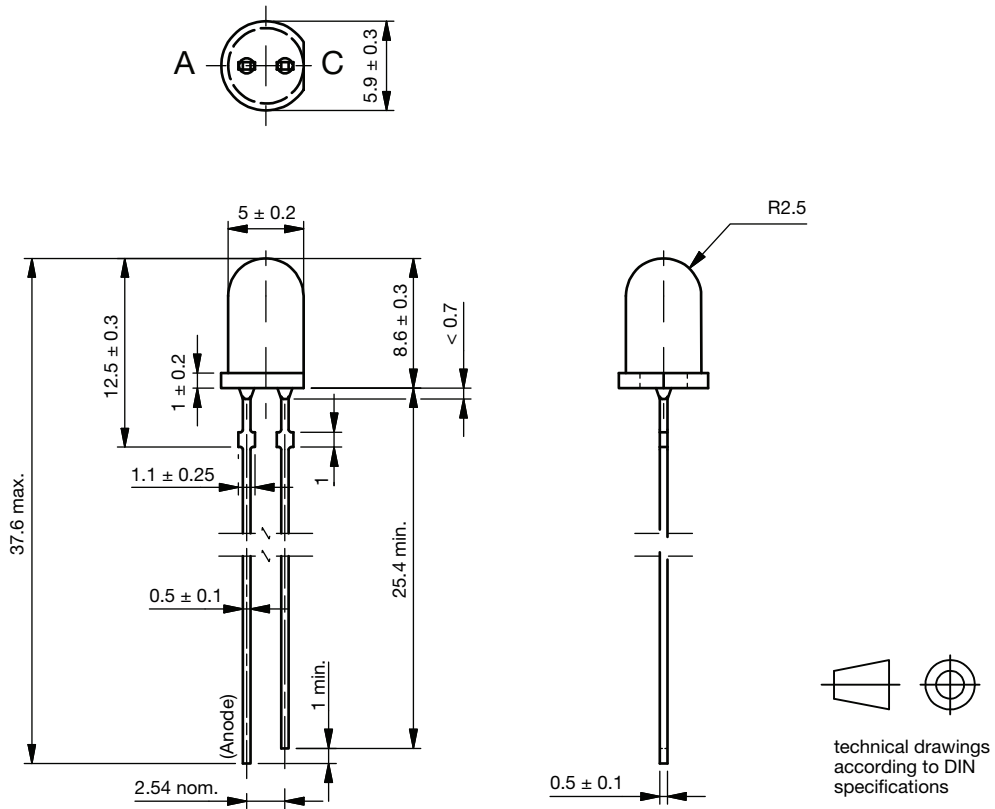

Fig. 6 - Relative Luminous Intensity vs. Ambient Temperature



PACKAGE DIMENSIONS FOR TLHG542. in millimeters



Drawing-No.: 6.544-5443.1-4
Issue: 1; 03.05.2023

PACKAGE DIMENSIONS FOR TLHG642. in millimeters

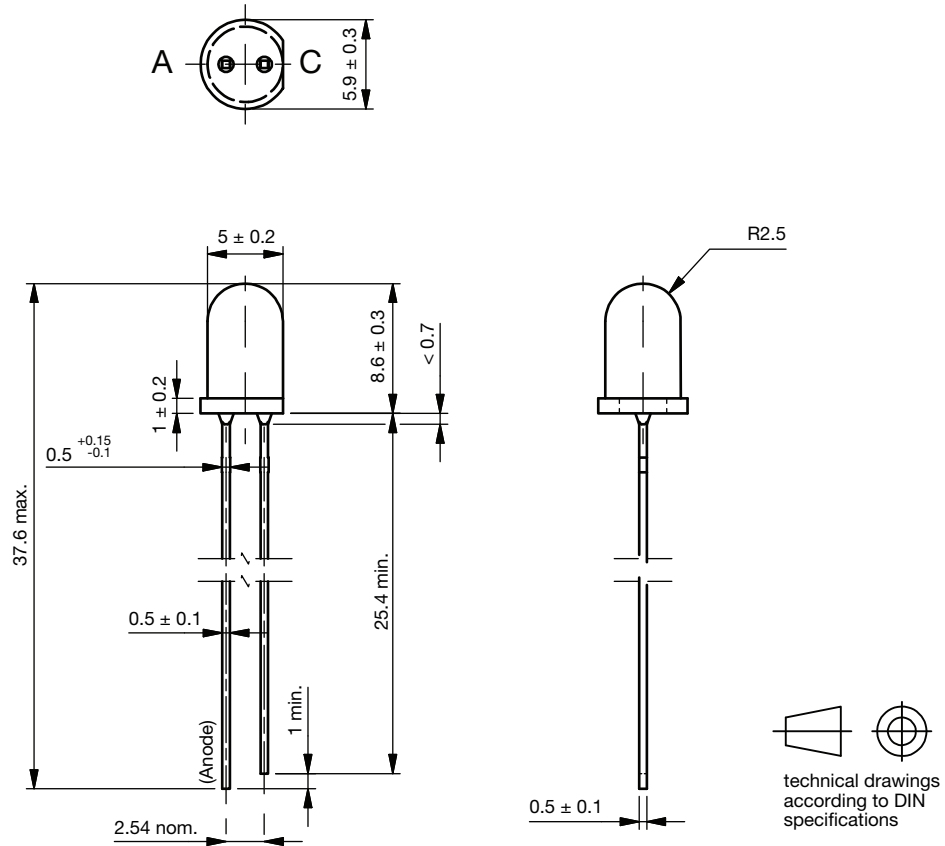

Drawing-No.: 6.544-5444.1-4
Issue: 1; 03.05.2023

AMMOPACK

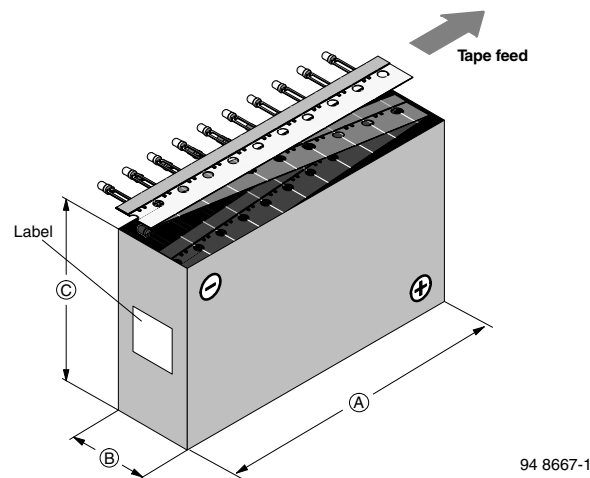

Fig. 7 - Tape Direction

Note

- The new nomenclature for ammpack is e.g. ASZ only, without suffix for the LED orientation. The carton box has to be turned to the desired position: "+" for anode first, or "-" for cathode first. AS12Z and AS21Z are still valid for already existing types, BUT NOT FOR NEW DESIGN



TAPE DIMENSIONS in millimeters

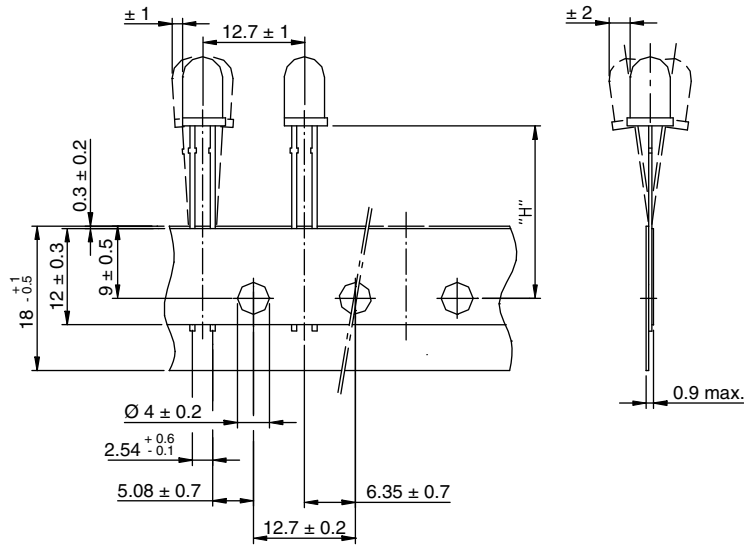

Quantity per:	Reel (Mat.-no. 1764)
	1000

94 8172

Option	Dim. "H" ± 0.5 mm	Dim. "X" ± 0.5 mm
AS	17.3	-
KS	19.7	-
CS	22.0	-

PACKING INFORMATION			
PART	BULK	TAPE AND REEL	AMMOPACK
TLHG542. / TLHG642.	4000	-	-
TLHG542.-.SZ / TLHG642.-.SZ	-	-	5 x 1000



BAR CODE PRODUCT LABEL (example)

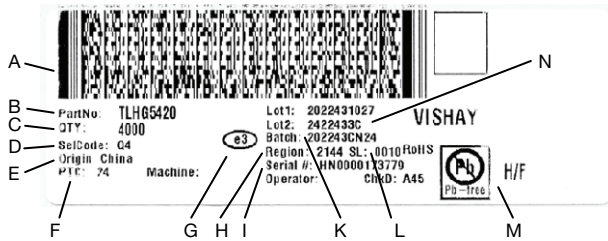

- A. 2D barcode
- B. Part No: Vishay part number
- C. QTY: quantity
- D. SelCode: selection bin code
- E. Country of origin
- F. PTC: production plant code
- G. Termination finish
- H. Region code
- I. Serial#: serial number
- K. Batch number: year, week, country code, plant code
- L. SL: storage location
- M. Environmental symbols: RoHS, lead (Pb)-free, halogen-free
- N. Lot numbers



Disclaimer

ALL PRODUCT, PRODUCT SPECIFICATIONS AND DATA ARE SUBJECT TO CHANGE WITHOUT NOTICE TO IMPROVE RELIABILITY, FUNCTION OR DESIGN OR OTHERWISE.

Vishay Intertechnology, Inc., its affiliates, agents, and employees, and all persons acting on its or their behalf (collectively, "Vishay"), disclaim any and all liability for any errors, inaccuracies or incompleteness contained in any datasheet or in any other disclosure relating to any product.

Vishay makes no warranty, representation or guarantee regarding the suitability of the products for any particular purpose or the continuing production of any product. To the maximum extent permitted by applicable law, Vishay disclaims (i) any and all liability arising out of the application or use of any product, (ii) any and all liability, including without limitation special, consequential or incidental damages, and (iii) any and all implied warranties, including warranties of fitness for particular purpose, non-infringement and merchantability.

Statements regarding the suitability of products for certain types of applications are based on Vishay's knowledge of typical requirements that are often placed on Vishay products in generic applications. Such statements are not binding statements about the suitability of products for a particular application. It is the customer's responsibility to validate that a particular product with the properties described in the product specification is suitable for use in a particular application. Parameters provided in datasheets and / or specifications may vary in different applications and performance may vary over time. All operating parameters, including typical parameters, must be validated for each customer application by the customer's technical experts. Product specifications do not expand or otherwise modify Vishay's terms and conditions of purchase, including but not limited to the warranty expressed therein.

Hyperlinks included in this datasheet may direct users to third-party websites. These links are provided as a convenience and for informational purposes only. Inclusion of these hyperlinks does not constitute an endorsement or an approval by Vishay of any of the products, services or opinions of the corporation, organization or individual associated with the third-party website. Vishay disclaims any and all liability and bears no responsibility for the accuracy, legality or content of the third-party website or for that of subsequent links.

Except as expressly indicated in writing, Vishay products are not designed for use in medical, life-saving, or life-sustaining applications or for any other application in which the failure of the Vishay product could result in personal injury or death. Customers using or selling Vishay products not expressly indicated for use in such applications do so at their own risk. Please contact authorized Vishay personnel to obtain written terms and conditions regarding products designed for such applications.

No license, express or implied, by estoppel or otherwise, to any intellectual property rights is granted by this document or by any conduct of Vishay. Product names and markings noted herein may be trademarks of their respective owners.