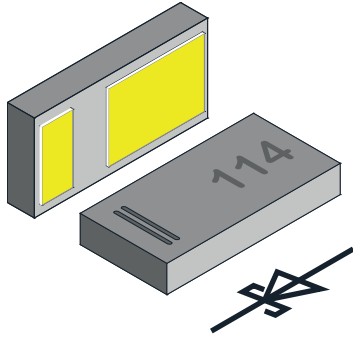

Schottky Rectifier Surface-Mount FlipKY® Gen 3

FEATURES

- Schottky diode for high-speed switching
- Very low dimensions: 1.6 mm x 0.8 mm x 0.29 mm
- 2.0 A forward current
- Low forward voltage drop (typ. 510 mV at 2000 mA)
- Low reverse current (< 25 μ A at 10 V)
- AEC-Q101 qualified
- Material categorization: for definitions of compliance please see www.vishay.com/doc?99912

AUTOMOTIVE GRADE

RoHS
 COMPLIANT
 HALOGEN
FREE
GREEN
 (5-2008)

LINKS TO ADDITIONAL RESOURCES



PARTS TABLE								
PART	GRADE	ORDERING CODE	CIRCUIT CONFIGURATION	PACKAGE NAME	TYPE MARKING	WEIGHT	TAPED UNITS PER REEL (8 mm TAPE ON 7" REEL)	MINIMUM ORDER QUANTITY
VSKY2040G8	AEC-Q101	VSKY2040G8HG4-08	Single	CLP1608-2L	114	0.84 mg	5000	5000

ABSOLUTE MAXIMUM RATINGS ($T_{amb} = 25\text{ }^{\circ}\text{C}$, unless otherwise specified)				
PARAMETER	TEST CONDITION	SYMBOL	VALUE	UNIT
Reverse voltage		V_R	40	V
Forward continuous current		I_F	2000	mA
Surge forward current	Single pulse; 8.3 ms half sine-wave	I_{FSM}	28	A

THERMAL CHARACTERISTICS ($T_{amb} = 25\text{ }^{\circ}\text{C}$, unless otherwise specified)				
PARAMETER	TEST CONDITION	SYMBOL	VALUE	UNIT
Thermal resistance junction to soldering point	Acc. JEDEC® JESD51-41	R_{thJS}	6	K/W
Maximum operating junction temperature		$T_j \text{ max.}$	150	$^{\circ}\text{C}$
Storage temperature range		T_{stg}	-65 to + 150	$^{\circ}\text{C}$

ELECTRICAL CHARACTERISTICS ($T_{amb} = 25\text{ }^{\circ}\text{C}$, unless otherwise specified)					
PARAMETER	TEST CONDITION	SYMBOL	TYP.	MAX.	UNIT
Leakage current	$V_R = 10\text{ V}$	I_R	-	25	μA
Leakage current	$V_R = 40\text{ V}$	I_R	-	110	μA
Forward voltage	$I_R = 100\text{ mA}$	V_F	300	343	mV
Forward voltage	$I_R = 1000\text{ mA}$	V_F	425	505	mV
Forward voltage	$I_R = 2000\text{ mA}$	V_F	510	620	mV
Diode capacitance	$V_R = 0\text{ V}, f = 1\text{ MHz}$	C_D	340	-	pF

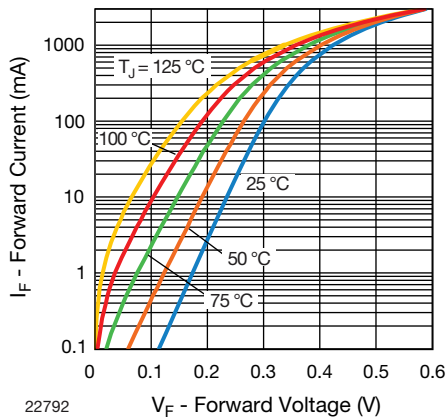
RATINGS AND CHARACTERISTICS CURVES ($T_A = 25^\circ\text{C}$ unless otherwise noted)



22792

Fig. 1 - Typical Forward Current vs. Forward Voltage at Various Temperatures

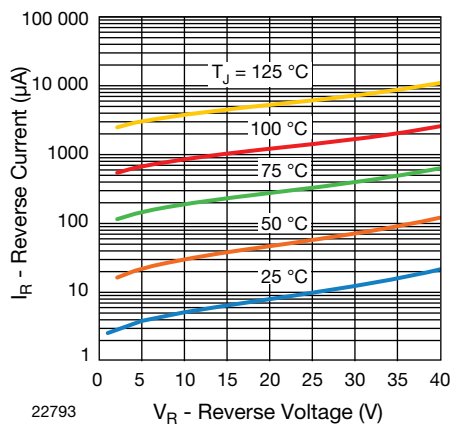

22793

Fig. 2 - Typical Reverse Current vs. Reverse Voltage at Various Temperatures

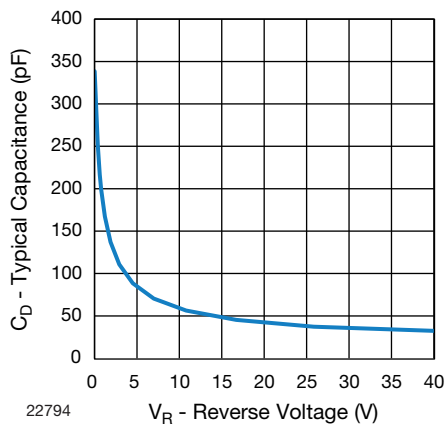

22794

Fig. 3 - Typical Capacitance vs. Reverse Voltage

PACKAGE DIMENSIONS in millimeters: **CLP1608-2L**

Package=Chip Dimensions in mm

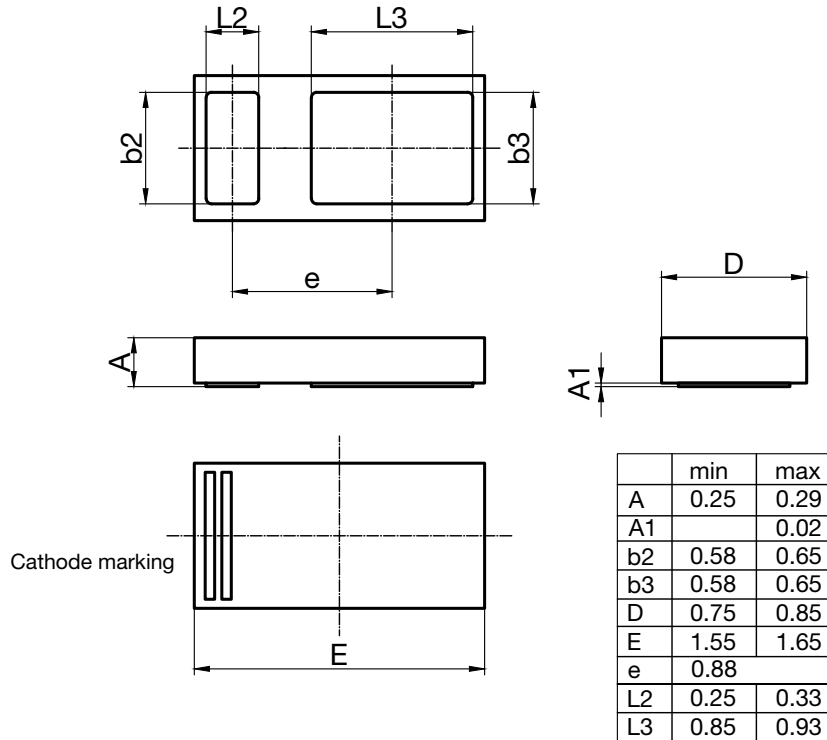

foot print recommendation:

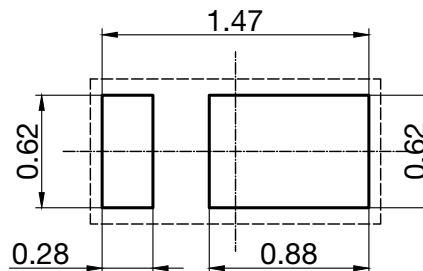

Document no.:S8-V-3906.04-033 (4)
 Created - Date: 10. Feb. 2014
 Rev.5 - Date: 19. Dec. 2023
 23233

Footprint and soldering recommendation:

please see Application Note: www.vishay.com/doc?85917



CARRIER TAPE in millimeters: **CLP1608-2L**

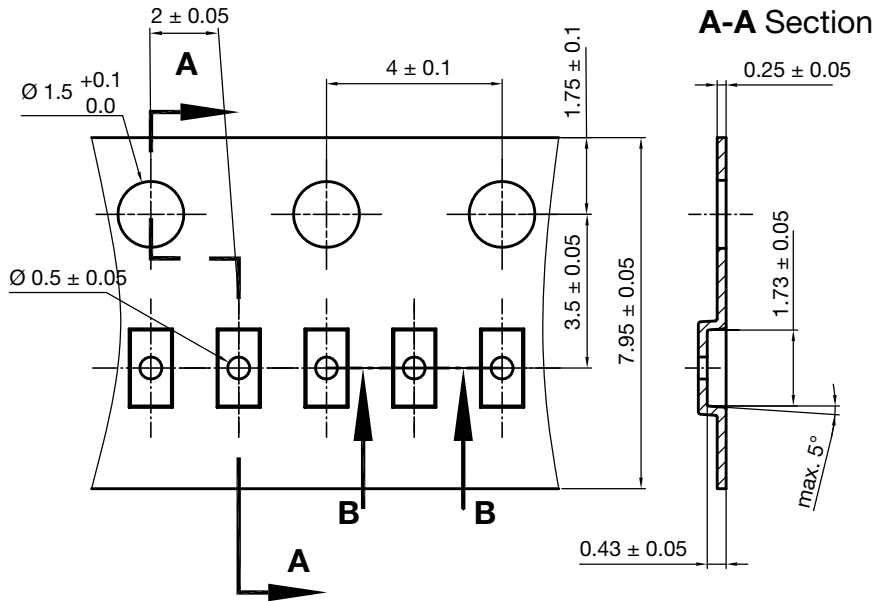

B-B Section

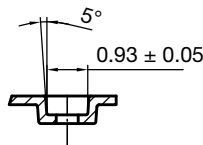

Document no.: S8-V-3906.04-034 (4)
Created - Date: 10. Feb. 2014
Rev.2 - Date: 28. Jan. 2016
23064

Cummlative tolerances of 10 sprocket holes is ± 0.2 mm

ORIENTATION IN CARRIER CLP1608-2L

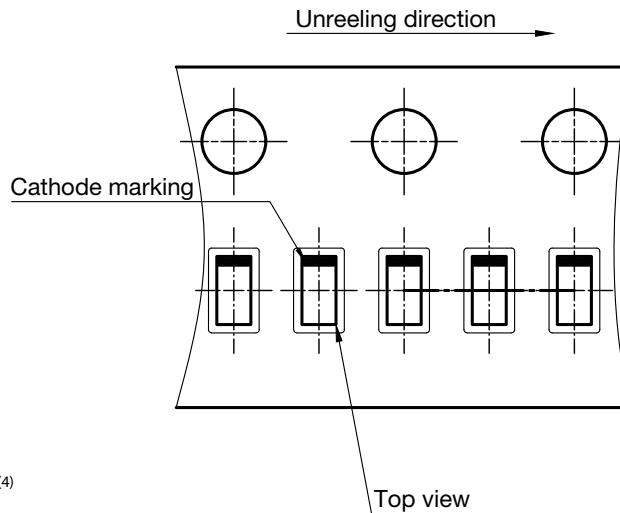

Document no.: S8-V-3906.04-035 (4)
Created - Date: 10. Feb. 2014
Rev.2 - Date: 19.12.2023
23063



Disclaimer

ALL PRODUCT, PRODUCT SPECIFICATIONS AND DATA ARE SUBJECT TO CHANGE WITHOUT NOTICE TO IMPROVE RELIABILITY, FUNCTION OR DESIGN OR OTHERWISE.

Vishay Intertechnology, Inc., its affiliates, agents, and employees, and all persons acting on its or their behalf (collectively, "Vishay"), disclaim any and all liability for any errors, inaccuracies or incompleteness contained in any datasheet or in any other disclosure relating to any product.

Vishay makes no warranty, representation or guarantee regarding the suitability of the products for any particular purpose or the continuing production of any product. To the maximum extent permitted by applicable law, Vishay disclaims (i) any and all liability arising out of the application or use of any product, (ii) any and all liability, including without limitation special, consequential or incidental damages, and (iii) any and all implied warranties, including warranties of fitness for particular purpose, non-infringement and merchantability.

Statements regarding the suitability of products for certain types of applications are based on Vishay's knowledge of typical requirements that are often placed on Vishay products in generic applications. Such statements are not binding statements about the suitability of products for a particular application. It is the customer's responsibility to validate that a particular product with the properties described in the product specification is suitable for use in a particular application. Parameters provided in datasheets and / or specifications may vary in different applications and performance may vary over time. All operating parameters, including typical parameters, must be validated for each customer application by the customer's technical experts. Product specifications do not expand or otherwise modify Vishay's terms and conditions of purchase, including but not limited to the warranty expressed therein.

Hyperlinks included in this datasheet may direct users to third-party websites. These links are provided as a convenience and for informational purposes only. Inclusion of these hyperlinks does not constitute an endorsement or an approval by Vishay of any of the products, services or opinions of the corporation, organization or individual associated with the third-party website. Vishay disclaims any and all liability and bears no responsibility for the accuracy, legality or content of the third-party website or for that of subsequent links.

Vishay products are not designed for use in life-saving or life-sustaining applications or any application in which the failure of the Vishay product could result in personal injury or death unless specifically qualified in writing by Vishay. Customers using or selling Vishay products not expressly indicated for use in such applications do so at their own risk. Please contact authorized Vishay personnel to obtain written terms and conditions regarding products designed for such applications.

No license, express or implied, by estoppel or otherwise, to any intellectual property rights is granted by this document or by any conduct of Vishay. Product names and markings noted herein may be trademarks of their respective owners.