

SlimSMA (DO-221AC)

TAPE INFORMATION

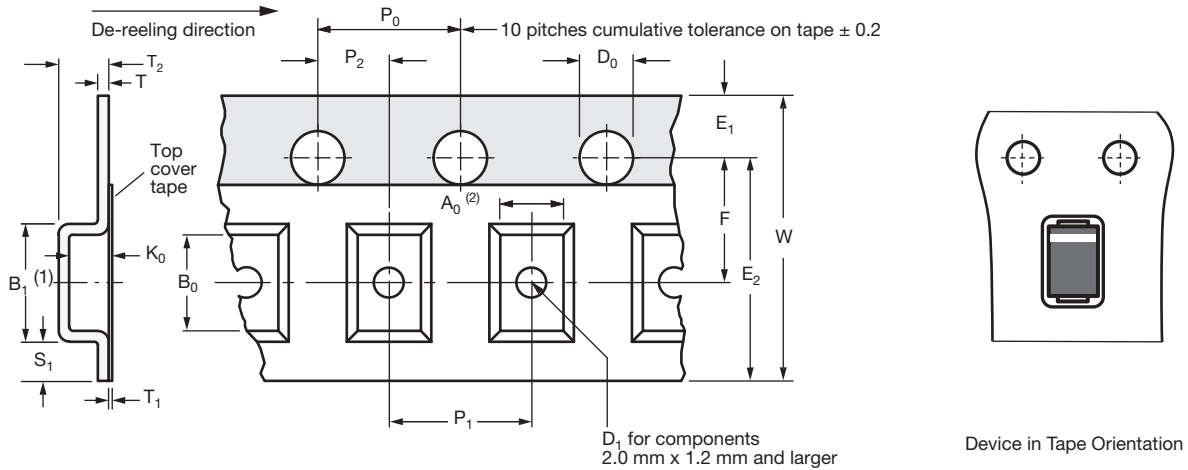

DIMENSIONS in millimeters (inches)							
TAPE SIZE	D_0	E_1	P_0	P_2	S_1 MIN.	T MAX.	T_1 MAX.
12 (0.472)	$1.5 + 0.1 / -0.0$ ($0.059 + 0.004 / -0.000$)	1.75 ± 0.1 (0.069 ± 0.004)	4.0 ± 0.1 (0.157 ± 0.004)	2.0 ± 0.05 (0.079 ± 0.002)	0.6 (0.024)	0.6 (0.024)	0.1 (0.004)
B_1 MAX.	D_1 MIN.	E_2 MIN.	F	P_1	R REF.	T_2 MAX.	W MAX.
6.2 (0.244)	1.5 (0.059)	10.25 (0.404)	5.5 ± 0.05 (0.217 ± 0.002)	4.0 ± 0.10 (0.157 ± 0.004)	25 (0.984)	1.53 (0.06)	12.3 (0.484)

Notes

- (1) For machine reference only, including draft and radii concentric around B_0
- (2) A_0 , B_0 , and K_0 are determined by the maximum dimensions of the component size. The clearance between the component and the cavity must be within 0.05 mm (0.002") min. to 0.5 mm (0.02") max. for 12 mm tape
- (3) All surface-mount components are packed in accordance with EIA standard 481-F

REEL INFORMATION

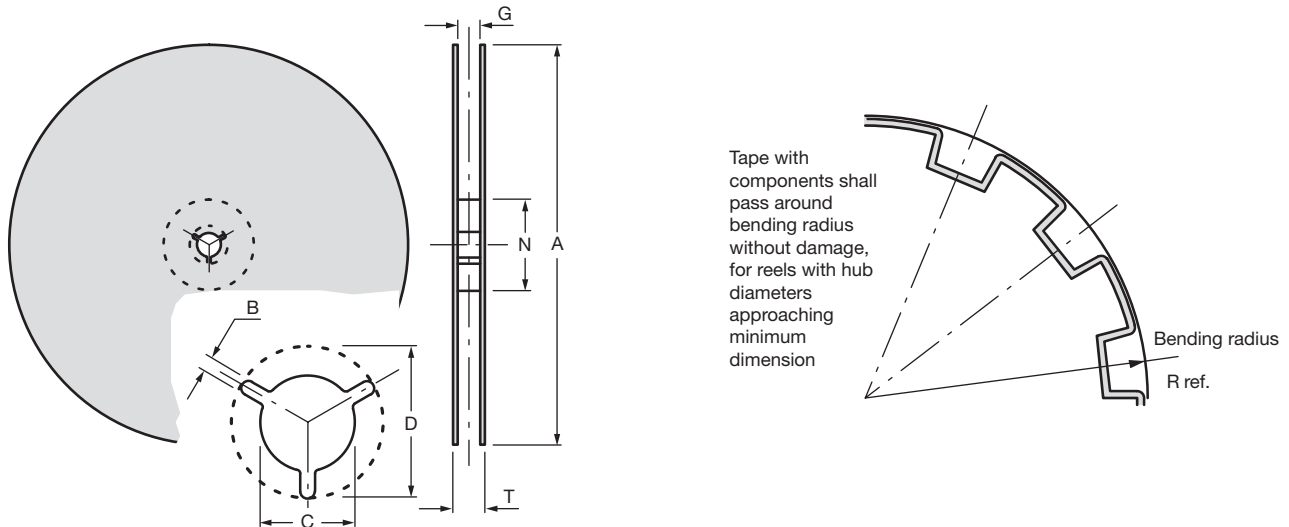

DIMENSIONS in millimeters (inches)							
PACKAGE CODE	A	B MIN.	C	D MIN.	N MIN.	G MAX.	T MAX.
6A, H (7" reel)	178 ± 2.0 (7.0 ± 0.079)	1.5 (0.059)	$13.0 + 0.50 / -20$ ($0.51 + 0.002 / -0.008$)	20.2 (0.795)	50 (1.97)	14.4 (0.567)	18.4 (0.724)
6B, I (13" reel)	330 ± 2.0 (13.0 ± 0.079)						